



## **Deluge System**

# **Technical Manual for Operation, Maintenance, and Troubleshooting**

**June, 2009**

Form No. F\_010708


**TECHNICAL DATA**
**DELUGE SPRINKLER  
SYSTEM**

The Viking Corporation, 210 N Industrial Park Drive, Hastings MI 49058

Telephone: 269-945-9501 Technical Services 877-384-5464 Fax: 269-818-1680 Email: techsvcs@vikingcorp.com

<u>Table of Contents</u>	<u>Page</u>
<b>I. SYSTEM DESCRIPTION</b>	<b>4</b>
<b>II. SYSTEM TYPES AND APPLICATIONS</b>	<b>4</b>
<b>III. SYSTEM REQUIREMENTS</b>	<b>4</b>
<b>IV. SYSTEM OPERATION</b>	<b>7</b>
<b>A. Deluge System Controlled by Hydraulic Release</b>	<b>14</b>
<b>B. Deluge System Controlled by Pneumatic Release</b>	<b>14</b>
<b>C. Deluge System Controlled by Electric Release</b>	<b>17</b>
<b>V. DELUGE VALVE</b>	<b>20</b>
<b>A. Description</b>	<b>20</b>
<b>B. Accessories</b>	<b>21</b>
<b>C. Operation</b>	<b>22</b>
<b>VI. THERMOSTATIC RELEASES</b>	<b>26</b>
<b>A. Description</b>	<b>26</b>
<b>B. Operation</b>	<b>27</b>
<b>C. Maintenance</b>	<b>27</b>
<b>D. Inspection</b>	<b>27</b>
<b>E. Operational Test</b>	<b>27</b>
<b>F. Disassembly</b>	<b>28</b>
<b>G. Adjustment</b>	<b>30</b>
<b>VII. FIXED TEMPERATURE RELEASE</b>	<b>31</b>
<b>A. Description</b>	<b>31</b>
<b>B. Operation</b>	<b>31</b>
<b>C. Maintenance</b>	<b>31</b>
<b>VIII. PNEUMATIC ACTUATOR</b>	<b>32</b>
<b>A. Description</b>	<b>32</b>
<b>B. Operation</b>	<b>32</b>
<b>C. Maintenance</b>	<b>32</b>
<b>D. Inspection</b>	<b>33</b>
<b>E. Disassembly</b>	<b>33</b>
<b>F. Reassembly</b>	<b>34</b>
<b>IX. PRESSURE OPERATED RELIEF VALVE (PORV)</b>	<b>34</b>
<b>A. Description</b>	<b>34</b>
<b>B. Operation</b>	<b>34</b>
<b>C. Inspections, Tests, and Maintenance</b>	<b>34</b>
<b>X. SOLENOID VALVE</b>	<b>36</b>
<b>A. Description</b>	<b>36</b>
<b>B. Operation</b>	<b>36</b>
<b>C. Inspections, Tests, and Maintenance</b>	<b>36</b>
<b>XI. EMERGENCY RELEASE</b>	<b>37</b>
<b>A. Description</b>	<b>37</b>
<b>B. Operation</b>	<b>37</b>
<b>C. Maintenance</b>	<b>37</b>
<b>D. Inspection</b>	<b>38</b>
<b>E. Testing</b>	<b>38</b>


**TECHNICAL DATA**
**DELUGE SPRINKLER  
SYSTEM**

The Viking Corporation, 210 N Industrial Park Drive, Hastings MI 49058  
 Telephone: 269-945-9501 Technical Services 877-384-5464 Fax: 269-818-1680 Email: techsvcs@vikingcorp.com

<b>Table of Contents Continued</b>		<b>Page</b>
<b>XII. RELEASE CONTROL PANEL</b>		<b>38</b>
<b>A. Description</b>		<b>38</b>
<b>B. Operation</b>		<b>38</b>
<b>C. Inspections, Tests and Maintenance</b>		<b>38</b>
<b>XIII. RELEASE LINE AIR SUPPLY ASSEMBLY</b>		<b>38</b>
<b>A. Description</b>		<b>38</b>
<b>B. Operation</b>		<b>39</b>
<b>C. Maintenance</b>		<b>39</b>
<b>XIV. AIR SUPPLIES FOR RELEASE SYSTEMS</b>		<b>40</b>
<b>A. Description</b>		<b>40</b>
<b>B. Model C-1 Thermostatic Release Systems with a Bottled Gas Supply</b>		<b>41</b>
<b>XV. DEHYDRATOR</b>		<b>41</b>
<b>A. Description</b>		<b>41</b>
<b>B. Operation</b>		<b>41</b>
<b>C. Maintenance</b>		<b>41</b>
<b>D. Disassembly</b>		<b>42</b>
<b>E. Reassembly</b>		<b>42</b>
<b>XVI. WATER-SPRAY FIXED SYSTEMS</b>		<b>42</b>
<b>A. System Applications</b>		<b>42</b>
<b>B. General Requirements</b>		<b>43</b>
<b>C. System Components</b>		<b>44</b>
<b>D. Hydraulic Calculations and Required Density</b>		<b>48</b>
<b>E. Exposure Protection of Transformers</b>		<b>48</b>
<b>F. Exposure Protection of Flammable Liquid Storage</b>		<b>50</b>
<b>G. Exposure Protection of Structural Steel</b>		<b>51</b>
<b>H. Exposure Protection of Metal Pipe, Tubing, and Conduit</b>		<b>52</b>
<b>I. Exposure Protection of Cable Trays and Cable Runs</b>		<b>52</b>
<b>J. Fire Extinguishment Protection of Cable Trays and Cable Runs</b>		<b>53</b>
<b>K. Fire Extinguishment Protection of Belt Conveyors</b>		<b>53</b>
<b>L. Control of Burning</b>		<b>54</b>
<b>M. Prevention of Fire</b>		<b>54</b>
<b>N. Automatic Detection Systems and Equipment</b>		<b>55</b>
<b>O. Water Spray System Maintenance</b>		<b>57</b>
<b>XVII. PLACING THE DELUGE SYSTEM IN SERVICE</b>		<b>57</b>
<b>XVIII. DELUGE SYSTEM INSPECTIONS, TESTS, AND MAINTENANCE</b>		<b>58</b>
<b>A. Quarterly Water Flow Alarm Test</b>		<b>58</b>
<b>B. Quarterly Main Drain Test</b>		<b>59</b>
<b>C. Annual Trip Test</b>		<b>59</b>
<b>D. Maintenance</b>		<b>60</b>
<b>XIX. REMOVING THE SYSTEM FROM SERVICE</b>		<b>62</b>
<b>XX. TROUBLESHOOTING VIKING DELUGE SYSTEMS</b>		<b>63</b>
<b>A. PORV</b>		<b>63</b>
<b>B. Pneumatic Actuator</b>		<b>64</b>

**TECHNICAL DATA****DELUGE SPRINKLER  
SYSTEM**

The Viking Corporation, 210 N Industrial Park Drive, Hastings MI 49058

Telephone: 269-945-9501 Technical Services 877-384-5464 Fax: 269-818-1680 Email: techsvcs@vikingcorp.com

**NOTE:** SPRINKLER SYSTEMS ARE ENGINEERED TO MEET THE STANDARDS OF NFPA 13, FM GLOBAL, LOSS PREVENTION COUNCIL (FOC), ASSEMBLEE PLENIERE, VERBAND DER SACHVERSICHERER (VDS) OR OTHER SIMILAR ORGANIZATIONS, AND WILL ALSO NEED TO COMPLY WITH THE PROVISIONS OF GOVERNMENTAL CODES, ORDINANCES, AND STANDARDS WHERE APPLICABLE. THE SYSTEM MUST BE DESIGNED BY QUALIFIED DESIGN PROFESSIONALS IN CONJUNCTION WITH INSURING BODIES. THE USER IS RESPONSIBLE FOR THE DESIGN AND CONFIGURATION OF THE SYSTEM, ITS APPROPRIATENESS FOR THE USE INTENDED AND ITS COMPLIANCE WITH ALL STANDARDS, CODES AND ORDINANCES. VIKING CORPORATION DOES NOT DESIGN SYSTEMS FOR SPECIFIC INSTALLATIONS AND MAKES NO REPRESENTATION OR WARRANTY CONCERNING WHETHER ANY SPECIFIC SYSTEM INSTALLATION WILL BE SUFFICIENT FOR THE INTENDED USE OR WILL COMPLY WITH ANY STANDARD, CODE, OR ORDINANCE. ANY SYSTEM DEPICTED IN THIS MANUAL IS SHOWN FOR ILLUSTRATIVE PURPOSES ONLY.

## I. SYSTEM DESCRIPTION

A Deluge System is a fixed fire protection system in which the pipe system is empty until the deluge valve operates to distribute pressurized water from open nozzles or sprinklers. Deluge systems are more complex than wet pipe and dry systems because they contain more components and equipment. The deluge valve is activated by operation of a fire detection system installed in the same area as the sprinklers (Figure 1). Various types of detection systems may be used, including smoke, heat, ultraviolet (UV), or infrared (IR) detection. The Viking deluge system can be activated by a hydraulic, pneumatic, electric, or manual release system or any combination of these release systems. But, in all cases, the deluge valve itself is activated hydraulically. When the detection device is activated, the deluge valve is tripped and water flows into the piping system, discharging through all spray nozzles or sprinklers simultaneously (Figure 2).

This technical manual will cover Viking deluge system design calculation, trim parts and their functions, as well as describe the proper operation, maintenance, and repair of valves and system devices.

## II. TYPES AND APPLICATIONS

Deluge systems are used where conditions of occupancy or special hazards require quick application of large quantities of water. These systems are used to create a buffer zone in high-hazard areas or in areas where fire may spread rapidly, and they can also be used to cool surfaces to prevent deformation or structural collapse or to protect tanks, process lines, or transformers against explosion. Other examples include storage or process areas containing substances having a low flash point; tanks containing combustible solutions, equipment pits or product handling systems. When designing a deluge system, efforts should be made to acquire specific information regarding the hazard to be protected.

Foam-water deluge systems are those using foam-water sprinklers or spray nozzles and an air-foam concentrate which is introduced into the water at controlled rate on the system side of the deluge valve. Foam water systems are used to control and/or extinguish fires which require a smothering and cooling agent. Examples are: extraction plants, aircraft hangars and areas where flammable-liquid spill fires may occur.

*Trimpac® Deluge Systems:* TRIMPAC® is a factory assembled trim package with a specific release device and release module (pneumatic or electric) in a metal enclosure. The standard trim normally required on a deluge valve has been moved to a single cabinet. TRIMPAC® provides access doors for the emergency release and alarm test valve for manual operation of these trim valves. TRIMPAC® is equipped with priming water pressure and water supply gauge view-ports for easy monitoring of water pressures. TRIMPAC® eliminates the installation of alarm trim piping and release trim piping at the deluge valve. The enclosure protects trim valves from inadvertent operation. Piping (or the included stainless steel hose package) from the valve body to the enclosure assembly allows the assembly to be installed remote of the sprinkler system riser. TRIMPAC® can be utilized for pneumatic or electric release deluge systems regardless of valve size. A valve drain package for the deluge valve is required and is ordered based on the deluge valve size. Refer to sections in this manual specifically for TRIMPAC®.



TECHNICAL DATA

DELUGE SPRINKLER SYSTEM

The Viking Corporation, 210 N Industrial Park Drive, Hastings MI 49058  
Telephone: 269-945-9501 Technical Services 877-384-5464 Fax: 269-818-1680 Email: techsvcs@vikingcorp.com

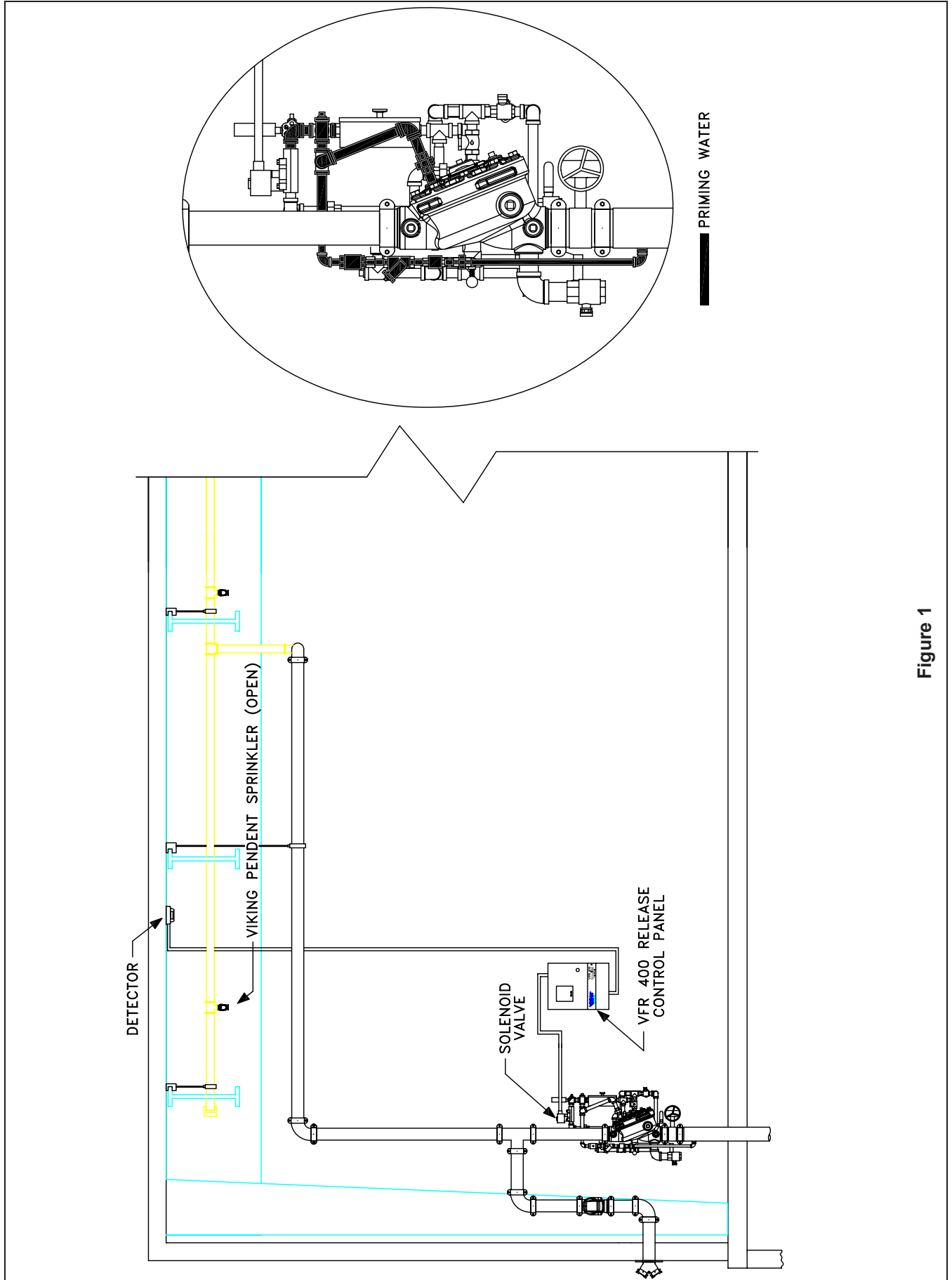


Figure 1



TECHNICAL DATA

DELUGE SPRINKLER SYSTEM

The Viking Corporation, 210 N Industrial Park Drive, Hastings MI 49058  
Telephone: 269-945-9501 Technical Services 877-384-5464 Fax: 269-818-1680 Email: techsvcs@vikingcorp.com

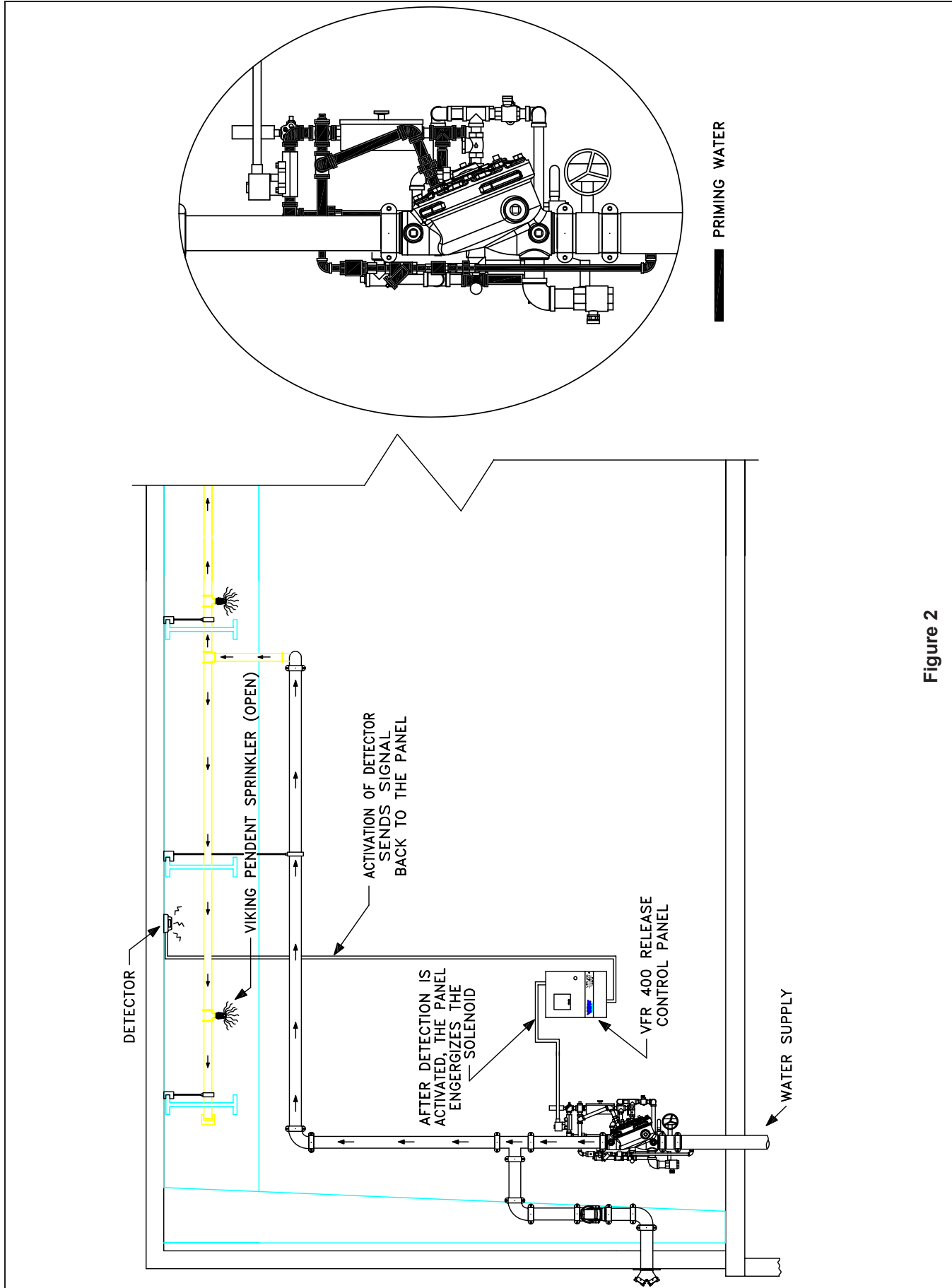


Figure 2



The Viking Corporation, 210 N Industrial Park Drive, Hastings MI 49058  
Telephone: 269-945-9501 Technical Services 877-384-5464 Fax: 269-818-1680 Email: techsvcs@vikingcorp.com

### System Size

Some installation standards state that a discharge rate of 3,000 gpm (11,355 L/min) should not be exceeded for a single system. System size may be further limited by the water supply available to the system and/or the hazard classification. If there is any question concerning the adequacy of the deluge system's coverage, seek the advice of the insurance underwriter or a qualified consulting engineering firm.

## III. SYSTEM REQUIREMENTS

Section 7.3 of NFPA 13-2007 provides the installation rules and characteristics that are unique to deluge systems. Also, refer to NFPA 72 National Fire Alarm Code for specific requirements on the design of hydraulic, pneumatic, and electrical detection systems.

Deluge systems are required to be hydraulically calculated. Since all sprinklers are open, every sprinkler on the system discharges water simultaneously when the deluge valve operates. Note: The system's area of operation is easy to determine; it is the entire area protected by the deluge system. Chapter 22 of NFPA 13 discusses the procedures for calculating the hydraulic demand of the sprinkler system and for verifying whether the available water supply will meet the requirements.

### Releasing Devices

Viking deluge equipment is designed to allow for a variety of release devices. The release system detection device itself may be thermostatic (fixed-temperature/rate-of-temperature-rise) or manual. Releasing devices, including automatic sprinklers used as releasing devices, are listed with specific spacing requirements that must be followed. Where thermal activation is utilized, the activation temperature of the release system shall be lower than the activation temperature of the sprinkler to ensure that the releasing system will operate before the sprinkler system. NOTE: Where heat-responsive devices are used, NFPA 13 requires a supply of spare fusible elements (at least 2 of each temperature rating) to be kept on the premises for replacement purposes.

The release system shall serve all areas that the deluge system protects to ensure that in the event of a fire, the release system will activate and provide water to the system and the affected area. NFPA 13 requires the detection devices or systems to be automatically supervised (monitored).

### Device Compatibility

All components of pneumatic, hydraulic, or electrical systems shall be compatible to ensure that all system components function as an integrated unit. For example, in electrical systems, the solenoid valve must be listed with the deluge valve, and the fire detection system, including the control panel. Correct coordination of the detection devices, the releasing equipment, and the control panel is imperative for prompt and reliable operation of the system.

### Manually-Operated Release System

Manually operated release systems are usually integrated into one of the other types of release systems. NFPA 13 requires the manual release device to be a stand-alone arrangement to ensure operation, regardless of the potential failure of the associated detection system. Normally a system will incorporate a manual release at the valve, exits, operator station, or other convenient locations to operate the system during a fire emergency.

### Release Control Panel

The release panel is an essential component for system operation and is required to be listed.

### Devices for Test Purposes and Testing Apparatus

Where detection devices installed in circuits are located where not readily accessible for testing, NFPA 13 requires an additional detection device to be provided on each circuit for test purposes at an accessible location. The device shall be connected to the circuit at a point that will ensure a proper test of the circuit.

**TECHNICAL DATA****DELUGE SPRINKLER  
SYSTEM**

The Viking Corporation, 210 N Industrial Park Drive, Hastings MI 49058

Telephone: 269-945-9501 Technical Services 877-384-5464 Fax: 269-818-1680 Email: techsvcs@vikingcorp.com

A means of producing the heat or impulse used to operate the detection device shall be available at the location. Where explosive vapors or materials are present, hot water, steam, or other methods of testing not involving an ignition source shall be used.

**Water Control Valves**

The automatic water control valve must be provided with hydraulic, pneumatic, or mechanical manual means for operation that is independent of detection devices and of the sprinklers.

**Valve Rooms and Protection Against Freezing**

Because the deluge valve is hydraulically operated, system water control valves and supply pipes must be protected against freezing. A heated enclosure may be required. NFPA 13 requires valve rooms to be lighted and heated with a permanent heat source, such as a baseboard or unit heater.

Note: Heat tape is not permitted to be used in lieu of heated valve enclosures to protect deluge valves and supply pipe against freezing.

**Pressure Gauges**

NFPA 13 requires listed pressure gauges to be installed below the deluge valve and on the air supply to deluge valves. Refer to NFPA 13 section 8.17.3 for additional information on gauges.

**Water Supply**

Since deluge systems are hydraulically-calculated, the static and residual water-pressure characteristics of the water supply should be obtained by conducting an on-site water-flow test. Prior water-supply data may already be available from the following sources: job specifications, consulting engineer, architect, insurance underwriter, owner, or local water department. Prior data must be applicable and may need to be verified. If a fire pump is needed, acquire a pump supply curve from the pump manufacturer. However, be sure to check with authorities having jurisdiction (approving body) regarding pump characteristics (percentage over rated capacity at percentage of rated PSI).

**Drainage**

A deluge system may produce a large volume of water. The owner should be notified as early as possible concerning the total volume of water expected to ensure proper drainage and, where necessary, collection.

**Floatable Combustible Liquids**

If the area being protected contains a large volume of floatable combustible liquid, a safe drainage or diking system should be installed to prevent the possibility of transferring the fire to adjacent areas.

**Equipment Shut-Down**

Because a deluge system applies water to the total system areas simultaneously, it may be advisable to install equipment that will automatically shut down selected production equipment. Examples of equipment that might be automatically shut down during deluge system operation are:

1. Equipment prone to more severe water damage when "ON" than "OFF".
2. Pumps, pipe lines, and conveyers supplying combustible solids, liquids, or gases to the system area.
3. Equipment that would present a serious electrical hazard if exposed to water (e.g. transformers, generators, conveyers, high-capacity battery chargers, high-amperage motors, etc.)
4. Large-volume air handling systems, if the drafting they create would serve to spread the fire to adjacent areas.



**TECHNICAL DATA****DELUGE SPRINKLER  
SYSTEM**

The Viking Corporation, 210 N Industrial Park Drive, Hastings MI 49058  
Telephone: 269-945-9501 Technical Services 877-384-5464 Fax: 269-818-1680 Email: techsvcs@vikingcorp.com

**Corrosive Atmospheres**

Request information from the owner or owner's representative regarding the system's environment. Corrosive elements may be present in the system's area, requiring a special material or protective coating for all deluge system components. Note: For outside exposed piping or where corrosive atmospheres exist, use steel/galvanized pipe and steel malleable or ductile iron fittings or copper.

**Draft Curtains**

Draft curtains may be required to separate each deluge system when multiple systems serve a common roofed area. The draft curtains suppress the operation of any system adjacent to the system serving the fire area. Proper placement of draft curtains will prevent the unnecessary use of water otherwise needed to fight the fire.

**Explosion-Proof Electrical Equipment**

If the system protects areas where explosive vapors may be present, explosion-proof electrical equipment is required. Check with the owner or other authorities regarding ratings.

**Flow Control Valve Substitution for Deluge Valve**

The Viking Flow Control Valve may be used for some deluge applications. This valve offers the same operating features as a deluge valve. In addition, it offers ON-OFF remote control. Refer to technical data in the Flow Control Valve section of the Viking Engineering and Design Data book for device and trimming requirements.

**IV. DELUGE SYSTEM OPERATION**

There are a number of arrangements that can be used for operating the deluge system. The simplest of these is to use sprinklers in a pilot line under system water pressure. The pilot line is piped from the priming chamber to the area protected with connections to the PORV and emergency release. When a pilot head operates, pressure in the priming chamber is relieved faster than it can be replenished through the restricted orifice. Supply pressure overcomes the clapper differential, forcing the clapper off its seat, allowing water to flow to the system outlets and sound the water flow alarm (Figure 3).



TECHNICAL DATA

DELUGE SPRINKLER SYSTEM

The Viking Corporation, 210 N Industrial Park Drive, Hastings MI 49058  
Telephone: 269-945-9501 Technical Services 877-384-5464 Fax: 269-818-1680 Email: techsvcs@vikingcorp.com

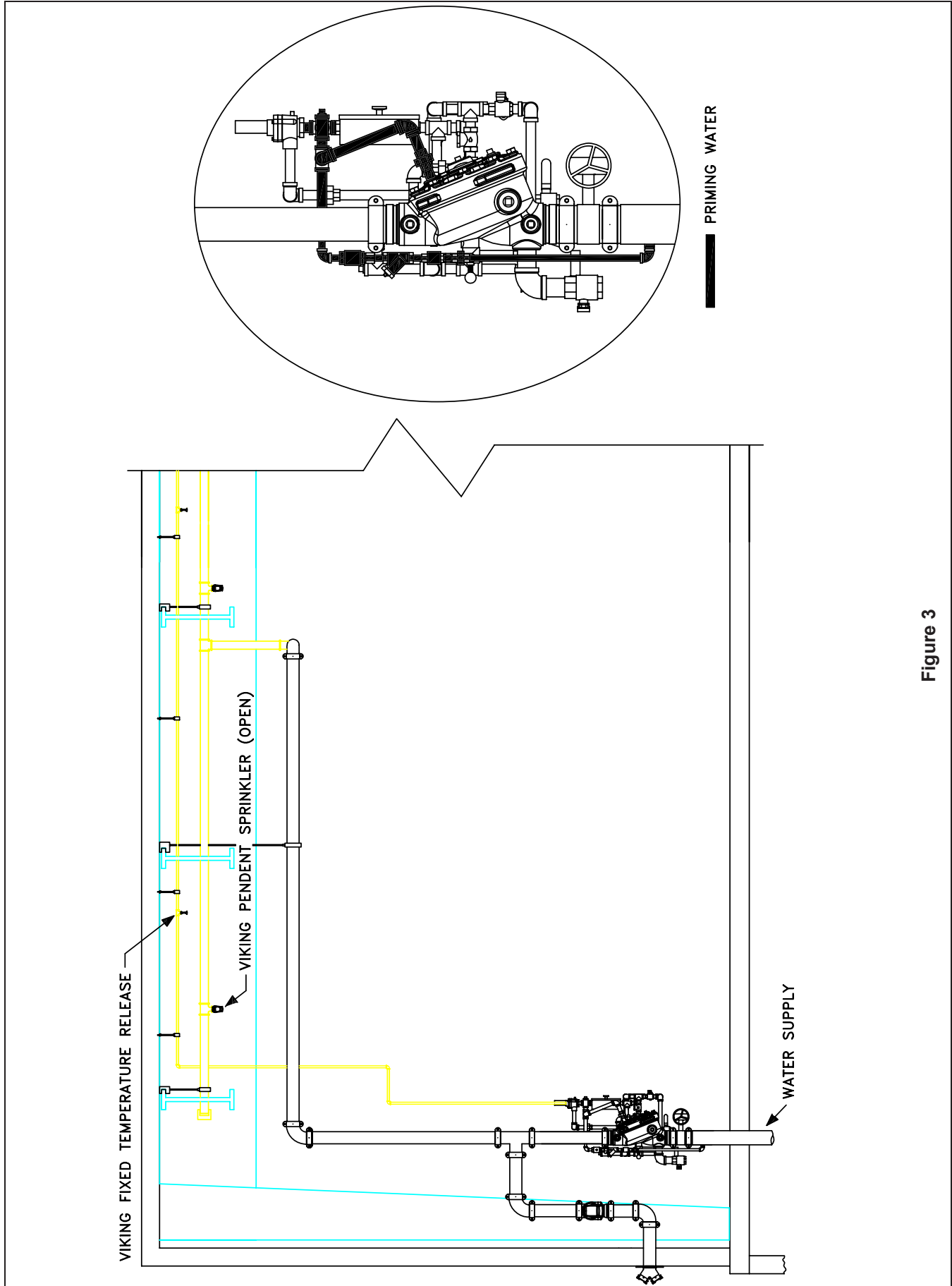


Figure 3



**TECHNICAL DATA**

**DELUGE SPRINKLER SYSTEM**

The Viking Corporation, 210 N Industrial Park Drive, Hastings MI 49058

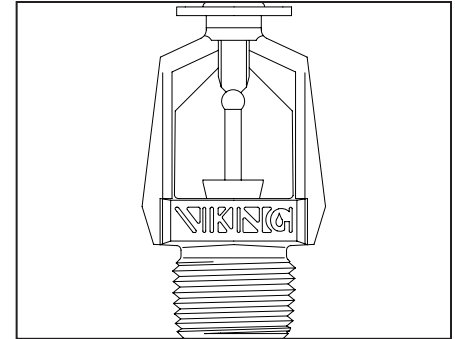
Telephone: 269-945-9501 Technical Services 877-384-5464 Fax: 269-818-1680 Email: techsvcs@vikingcorp.com

Any listed sprinkler can be used on the system, however, Viking recommends the MicrofastHP® Fixed Temperature Release because of its maximum spacing allowance (Figure 4). While simple, this method of release may not be fast enough in many situations.

To speed up system operation, the most common release device utilized is the Viking Model C Rate of Rise Release. The Model C will activate the system when the temperature in the protected area increases at a rate of more than 15 °F per minute. It is equipped with a fixed temperature fusing element. The release can be mounted at any angle and there is no limit on the number of them that can be on a single line (Figure 5).

A unit is self-resetting when operated as a rate of rise device.

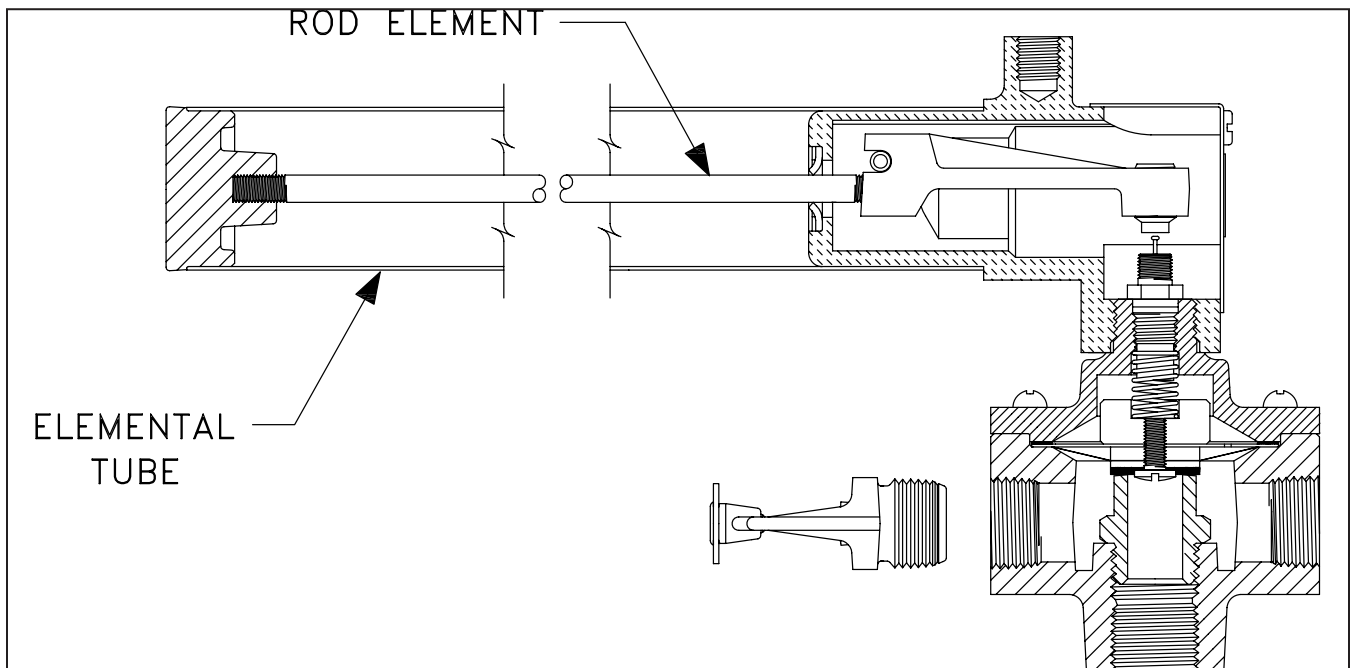
Pressure from the release line flows through a small hole in the release's diaphragm to exert pressure on the diaphragm, forcing the clapper in the release closed against its seat. The mechanics of release operation begin with a rapid change in temperature. When the release is subjected to a rate of temperature increase greater than 15 °F per minute, the tube element expands more rapidly than the rod element because of its relatively large surface area and small mass (Figure 6).



**Figure 4:**  
Fixed Temperature Release VK800



**Figure 5:** Model C-1 Thermostatic Release



**Figure 6**



## TECHNICAL DATA

## DELUGE SPRINKLER SYSTEM

The Viking Corporation, 210 N Industrial Park Drive, Hastings MI 49058

Telephone: 269-945-9501 Technical Services 877-384-5464 Fax: 269-818-1680 Email: techsvcs@vikingcorp.com

The force pulling on the lever arm depresses a schrader valve stem, sending the pressure above the diaphragm faster than it can be replenished through the small hole in the diaphragm (Figure 7). The pressure under the clapper lifts it, allowing the release line pressure to be vented through the drain outlet (Figure 8).

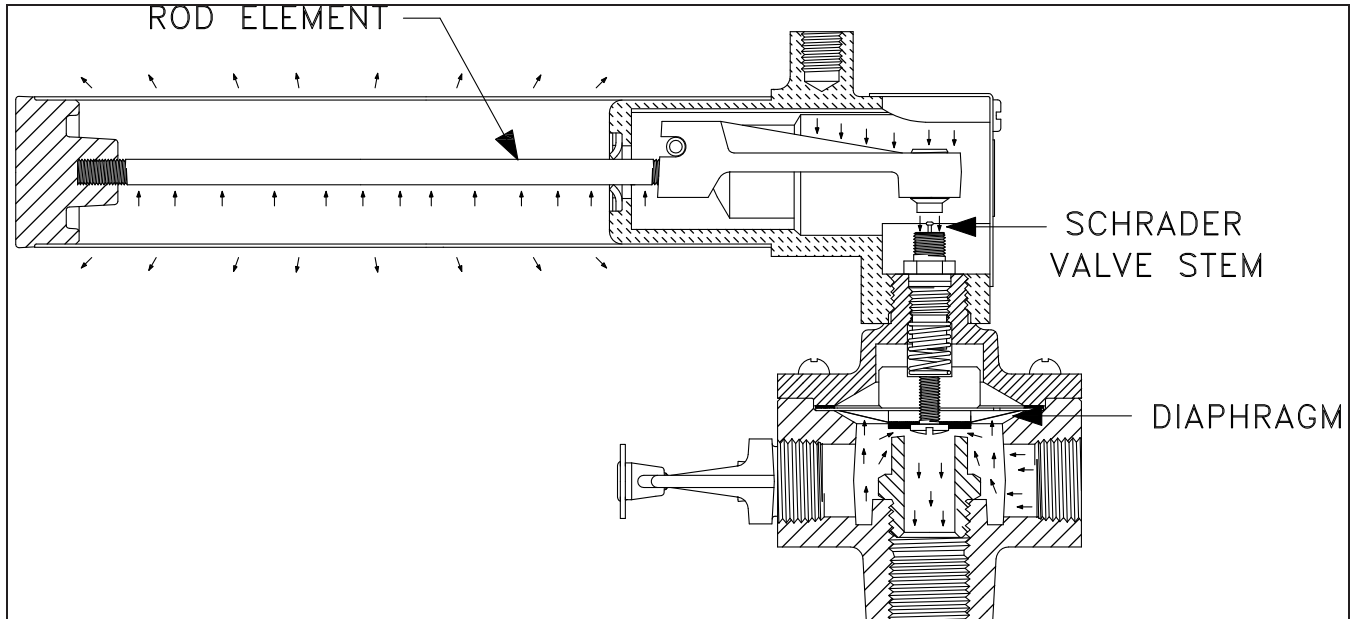


Figure 7

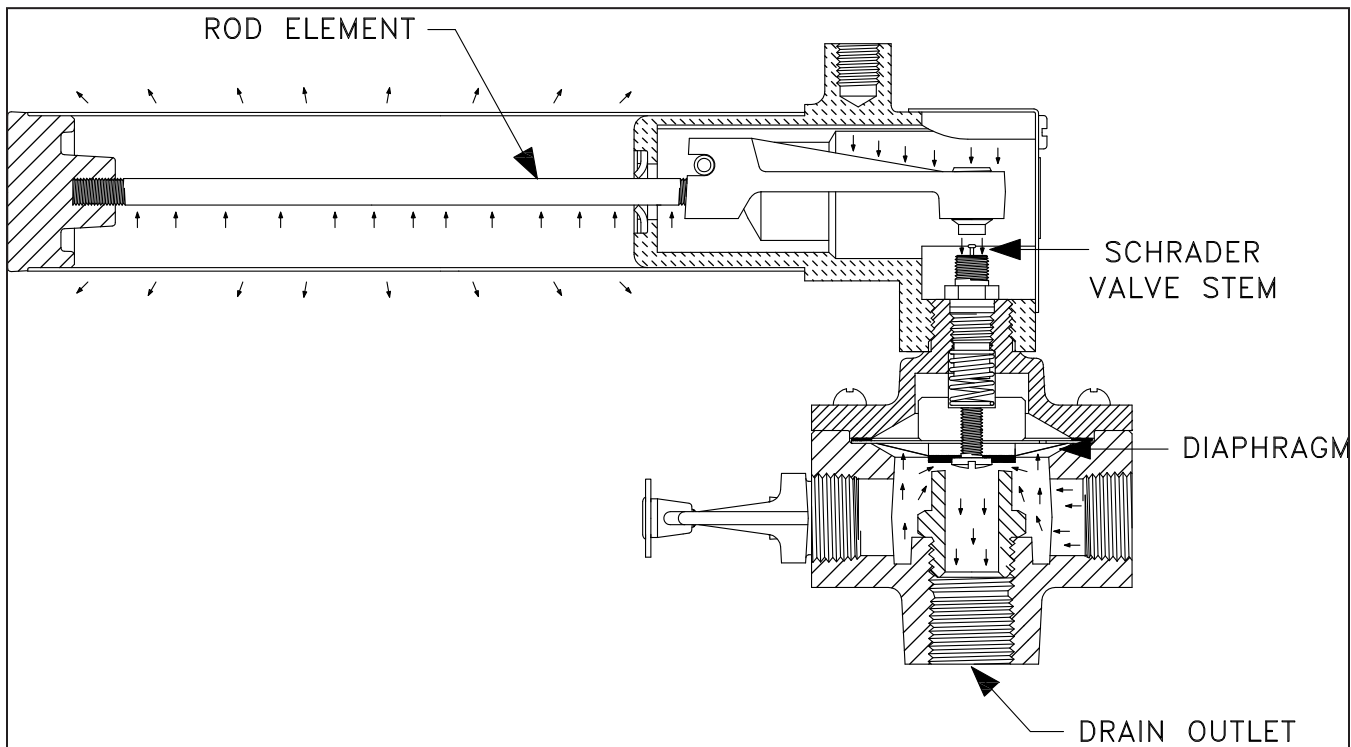


Figure 8



## TECHNICAL DATA

## DELUGE SPRINKLER SYSTEM

The Viking Corporation, 210 N Industrial Park Drive, Hastings MI 49058

Telephone: 269-945-9501 Technical Services 877-384-5464 Fax: 269-818-1680 Email: techsvcs@vikingcorp.com

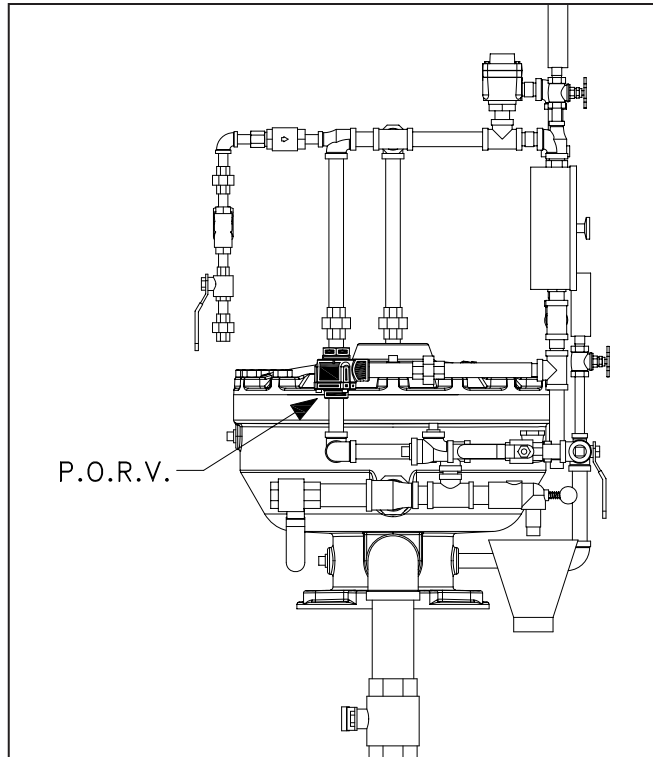


Figure 9

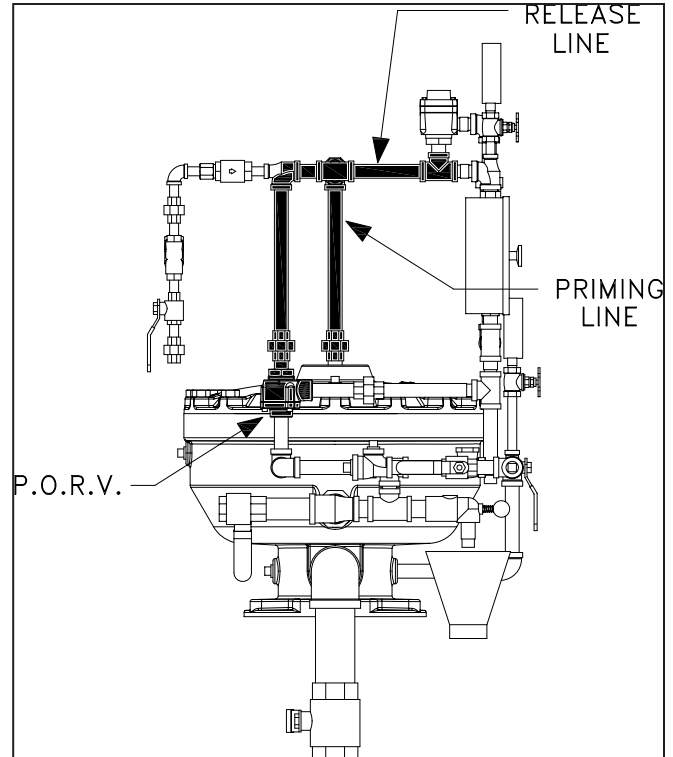


Figure 10

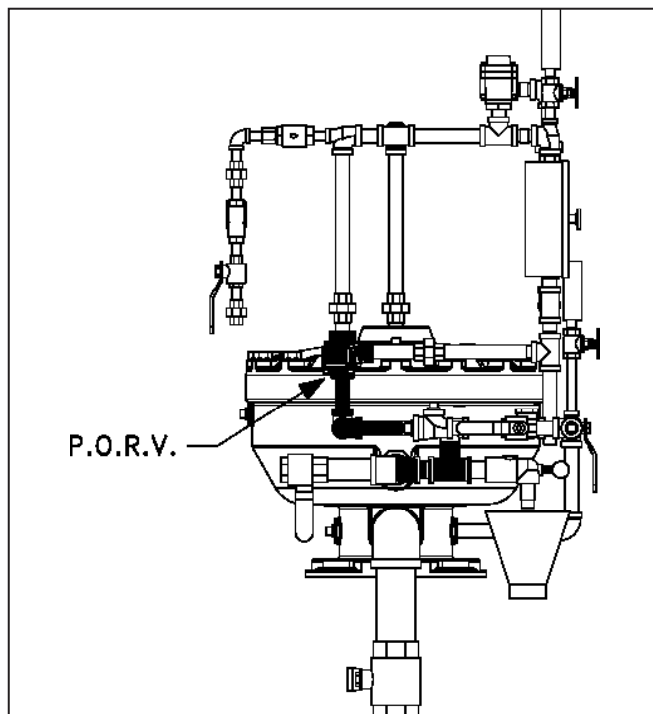


Figure 11

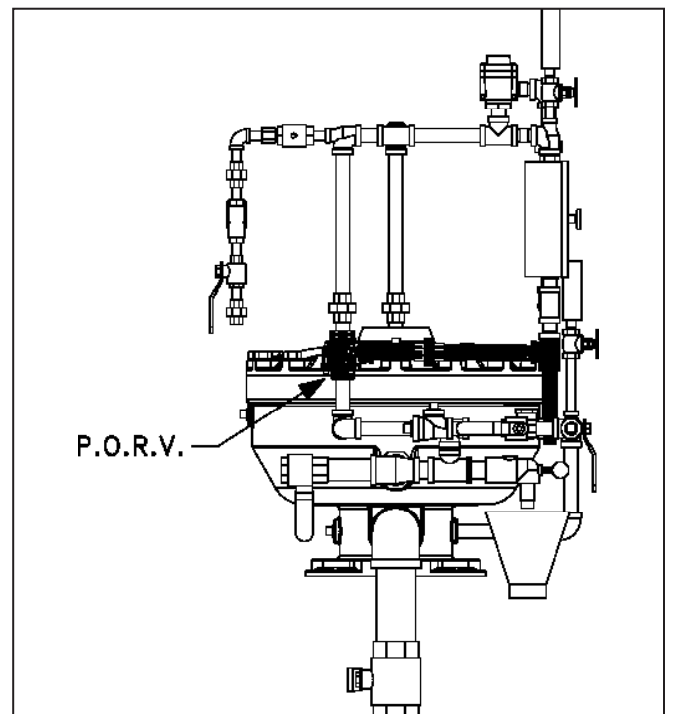


Figure 12

The deluge system trim incorporates a unique pressure operated relief valve (PORV) (Figure 9). The PORV operates much like the Model C Release. The PORV maintains a positive vent on the priming chamber to prevent the deluge valve from automatically resetting. It is a means of keeping the valve open if the detection system fails and resets. One end of the PORV is connected to the piping of the deluge valve priming chamber to the release line (Figure 10). A second inlet is plugged. The PORV also has a pipe connection from the outlet side of the deluge valve (Figure 11). It has two drain outlets, which must not be plugged and must be piped to atmosphere (Figure 12).



## TECHNICAL DATA

## DELUGE SPRINKLER SYSTEM

The Viking Corporation, 210 N Industrial Park Drive, Hastings MI 49058

Telephone: 269-945-9501 Technical Services 877-384-5464 Fax: 269-818-1680 Email: techsvcs@vikingcorp.com

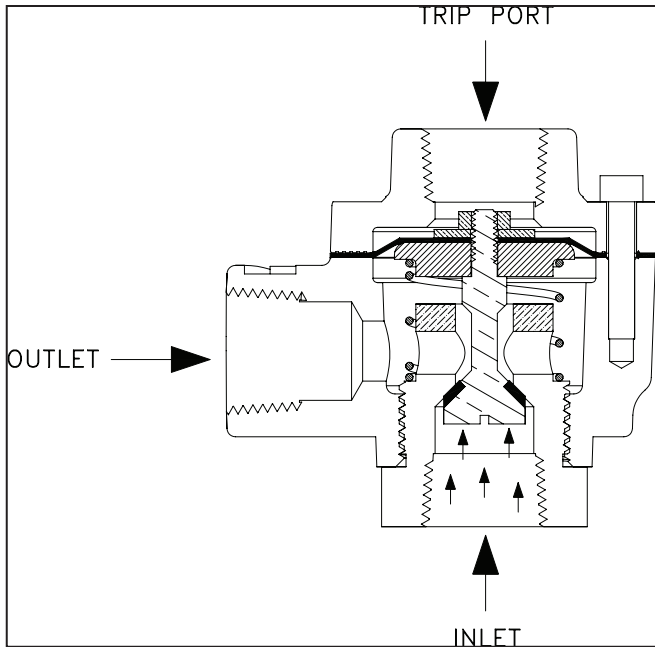


Figure 13

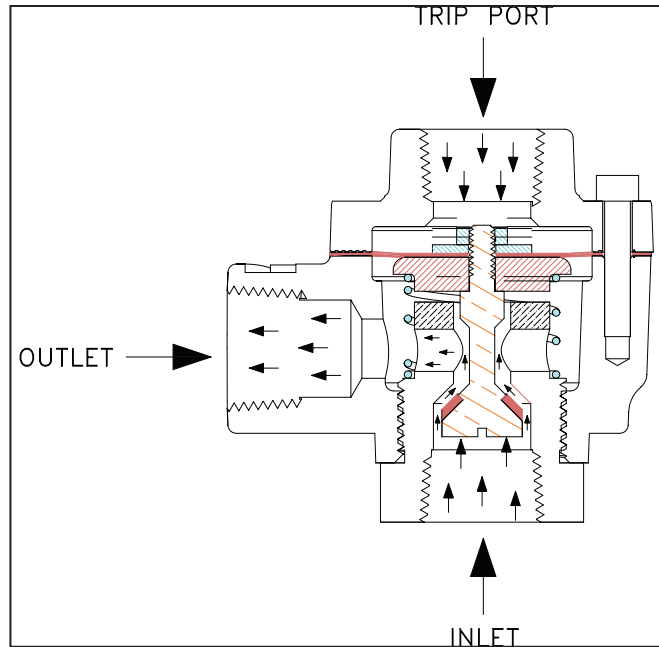


Figure 14

### For Deluge Valves Equipped with Conventional Trim

When the deluge valve operates, the sensing end of the PORV is pressurized, causing the PORV to operate (Figures 13-14). When the PORV operates, it continually vents the priming chamber to prevent the deluge valve from resetting even if the open releasing devices close. The deluge valve can only be reset after the system is taken out of service, and the outlet chamber of the deluge valve and associated trim piping is depressurized and drained.

### A. Deluge System Controlled by Hydraulic Release

Hydraulic release systems may utilize rate-of-temperature rise, fixed-temperature, manual releasing devices, or combinations thereof. Hydraulic release systems are normally the least expensive of possible release systems; however, they must not be installed in areas that are not subject to freezing.

**Release Lines:** Use galvanized steel pipe or corrosion-resistant tubing, such as copper or brass for release lines. Do not exceed 1,000 ft. (304.8 m) of ½" (15 mm) pipe in a release-line system. In systems over this capacity, larger pipe sizing is required.

**Maximum Allowable Height Of Release Line Above The Deluge Valve:** Under certain conditions, the deluge valve may be subject to water columning. To prevent this, hydraulic release system piping must not exceed the maximum elevation allowed for hydraulic release piping above the deluge valve as indicated in the listing. Refer to current technical data for the Viking deluge valve used.

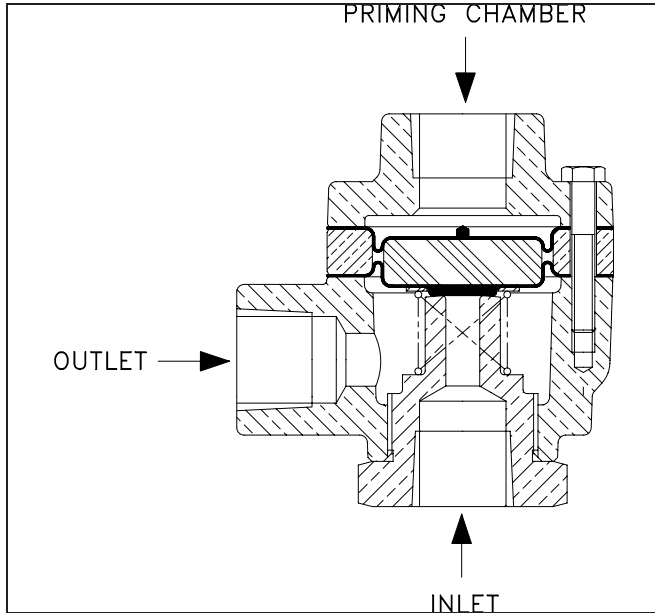
### B. Deluge System Controlled by Pneumatic Release

Pneumatic release systems may utilize rate-of-temperature-rise, fixed-temperature, manual releasing devices, or combinations thereof. Pneumatic release systems may be used in most areas. Costs of installation and maintenance are usually higher than a comparable hydraulic release system. Valve trip-time may vary depending on the length of the release line and the air pressure maintained on the release system.

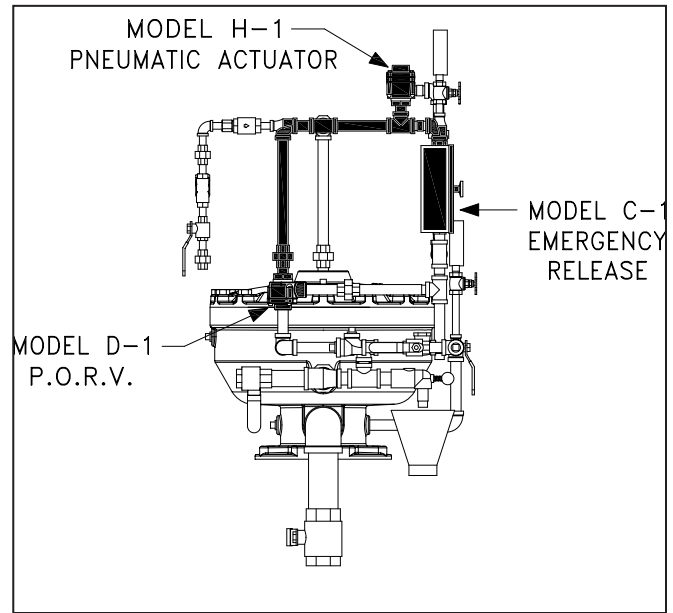
Air is commonly used in the release line where freezing is a concern. However, air systems require a dry air supply, a means of transitioning from air to water in the release line, and a release line maximum of 1,000 ft. The device used to accomplish the transition is Viking's Model H-1 Pneumatic Actuator (Figure 15). The pneumatic actuator is installed in the release line downstream from the PORV and emergency release connections (Figure 16).

	<b>TECHNICAL DATA</b>	<b>DELUGE SPRINKLER SYSTEM</b>
--	-----------------------	--------------------------------

The Viking Corporation, 210 N Industrial Park Drive, Hastings MI 49058  
 Telephone: 269-945-9501 Technical Services 877-384-5464 Fax: 269-818-1680 Email: techsvcs@vikingcorp.com

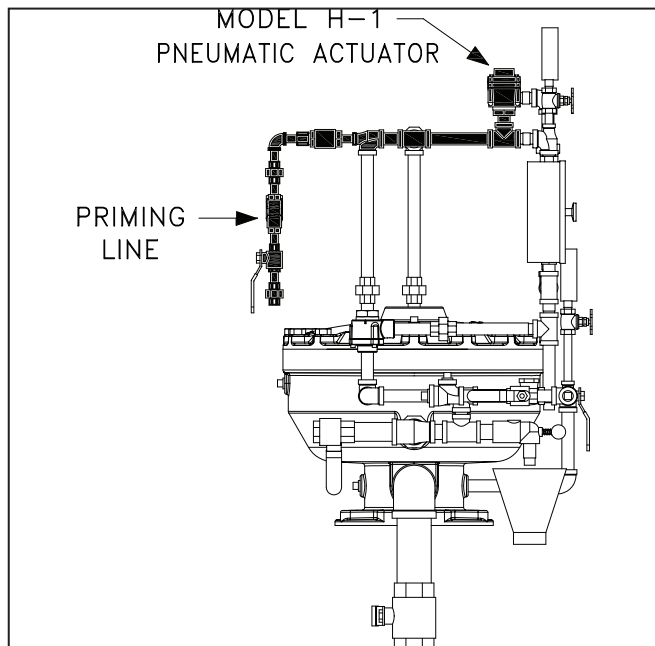


**Figure 15: Model H-1 Pneumatic Actuator**

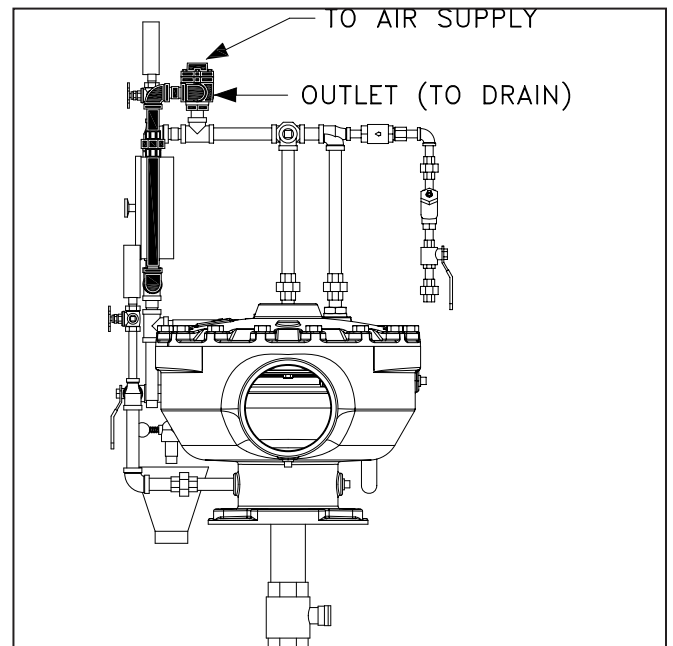


**Figure 16**

Its inlet is subject to system water pressure (Figure 17). Its priming chamber is subject to release line air pressure of 30 PSI and its outlet is open to drain (Figure 18).



**Figure 17**



**Figure 18**



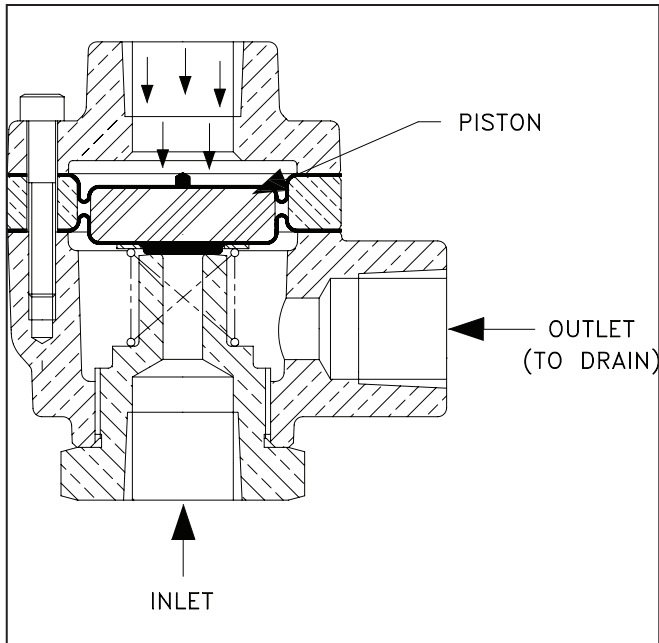
## TECHNICAL DATA

## DELUGE SPRINKLER SYSTEM

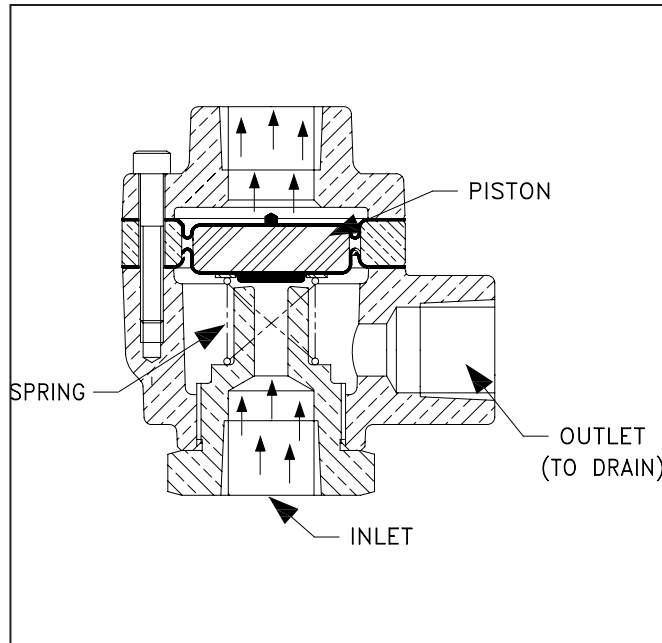
The Viking Corporation, 210 N Industrial Park Drive, Hastings MI 49058

Telephone: 269-945-9501 Technical Services 877-384-5464 Fax: 269-818-1680 Email: techsvcs@vikingcorp.com

Air pressure on the priming chamber of the actuator forces the diaphragm and piston assembly to seal the inlet from the outlet (Figure 19). With its differential design, the relatively low pressure in the priming chamber will control a higher water inlet pressure. When a pilot line release opens and relieves air pressure in the actuator priming chamber, the inlet pressure and the spring force the diaphragm and the piston assembly to move, allowing the inlet water pressure to be relieved through the outlet (Figure 20).



**Figure 19**



**Figure 20**

**Pressure to be Maintained in a Pneumatic Release System:** For recommended pneumatic (air or nitrogen) pressures to be maintained in pneumatic release systems, refer to current Viking technical data for the system used. For additional information concerning pneumatic release system equipment, devices, and installation instructions, refer to the Viking Engineering and Design Data book section describing Pneumatic Supplies.

**Release Line Restriction:** All pneumatic-release systems must be equipped with a restricted orifice in the air or gas supply to ensure that the automatic air supply cannot replace pneumatic pressure as fast as it escapes when a releasing device operates. This restriction is already incorporated in the Viking air maintenance device and release line air supply assembly.

**Reducing Trip Time:** If the deluge system trip time is excessive, it can be substantially reduced by one or more of the following:

1. Add a check valve (Circle Seal or equivalent) in branch portions of the release-line system. (Install so flow is toward releasing device).
2. Install an optional accelerator on the pneumatic release system to provide earlier alarms and/or allow the system to trip faster. An Accelerator may be necessary to meet system discharge time requirements.

**Release Line Dehydrator:** All pneumatic release systems must be provided with an air dehydrator to minimize corrosion and prevent ice plugs.

**Pneumatic Supply:** Refer to Viking technical data, system data, and associated schematic drawings for the deluge system used. Also, refer to the Viking Engineering and Design Data book section describing "Pneumatic Supplies" for additional information on pneumatic (air or nitrogen) equipment, devices, and installation requirements.





## TECHNICAL DATA

## DELUGE SPRINKLER SYSTEM

The Viking Corporation, 210 N Industrial Park Drive, Hastings MI 49058

Telephone: 269-945-9501 Technical Services 877-384-5464 Fax: 269-818-1680 Email: techsvcs@vikingcorp.com

*Trimpac® Deluge Systems Controlled by Pneumatic Release:* TRIMPAC® Model B-2, B-2B & B-2S incorporates a pneumatic release module that controls the pressurization of the priming chamber of the deluge valve. Water is supplied to the deluge valve's priming chamber from an outlet upstream of the water supply control valve. Water flow to Point #1 of TRIMPAC® Model B-2, B-2B & B-2S passes through the normally opened priming valve, Y strainer, 1/16" restricted orifice, and spring loaded check valve. Water is supplied to the inlet side of the normally closed pneumatic actuator (air pressure must be placed on the pneumatic release line to close the pneumatic actuator) and to the priming side of the P.O.R.V. Priming water exits the TRIMPAC® to Point #2 of the TRIMPAC® passing to the priming chamber of the deluge valve, pressurizing the deluge valve closed. (Priming pressure can be identified at the priming pressure gauge view-port on the TRIMPAC®.) Once priming pressure is present in the priming chamber of the deluge valve, the water supply control valve can be opened. Once the water supply control valve is opened, water will pressurize the inlet chamber of the deluge valve, water will exit the inlet chamber of the deluge valve and enter Point #5 of the TRIMPAC®. After water enters Point #5 of the TRIMPAC® it will pressurize the water supply pressure gauge. Water pressure will now be available on the inlet of the normally closed alarm test valve. The valve and trim assembly is now in a normal operation mode.

*Trimpac® in Fire Conditions:* Deluge systems with a pneumatic release require a pneumatic release device to activate in the hazard area which relieves the air pressure from the sensing side of the pneumatic actuator in the TRIMPAC®. The pneumatic actuator opens releasing the water pressure in the deluge valves priming chamber. Priming water is discharged from the outlet of the pneumatic actuator to a drain cup. Once the priming water pressure is relieved in the priming chamber of the deluge valve, water supply pressure will pass from the inlet of the deluge valve to the outlet of the deluge valve to the sprinkler piping. During deluge valve operation, water is discharged through the valve drain package to Point #4 of the TRIMPAC®. Water enters Point #4 of the TRIMPAC® to activate the water flow alarms and pressurize the sensing side of the P.O.R.V. Once the sensing side of the P.O.R.V. is pressurized, priming water will be vented from the drain end of the P.O.R.V. through Point #3 of TRIMPAC® to the drain cup.

### C. Deluge System Controlled by Electric Release

Viking deluge systems can be activated electrically through the use of a solenoid valve installed off the release line downstream from the PORV and the emergency release connection (Figure 21). A strainer should be installed as close as possible to the inlet side of the solenoid valve (Figure 22).

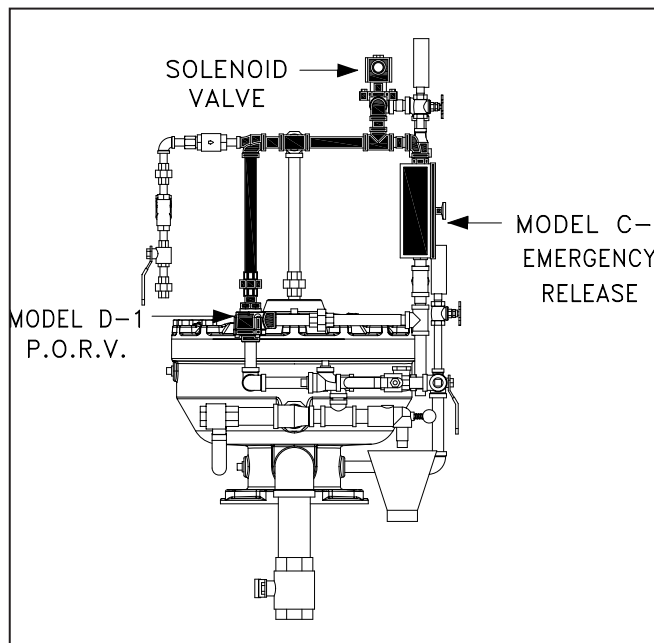


Figure 21

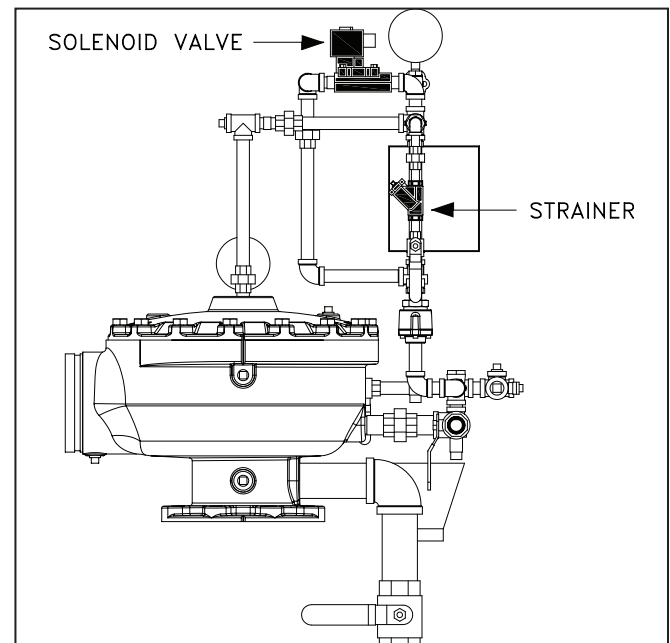


Figure 22



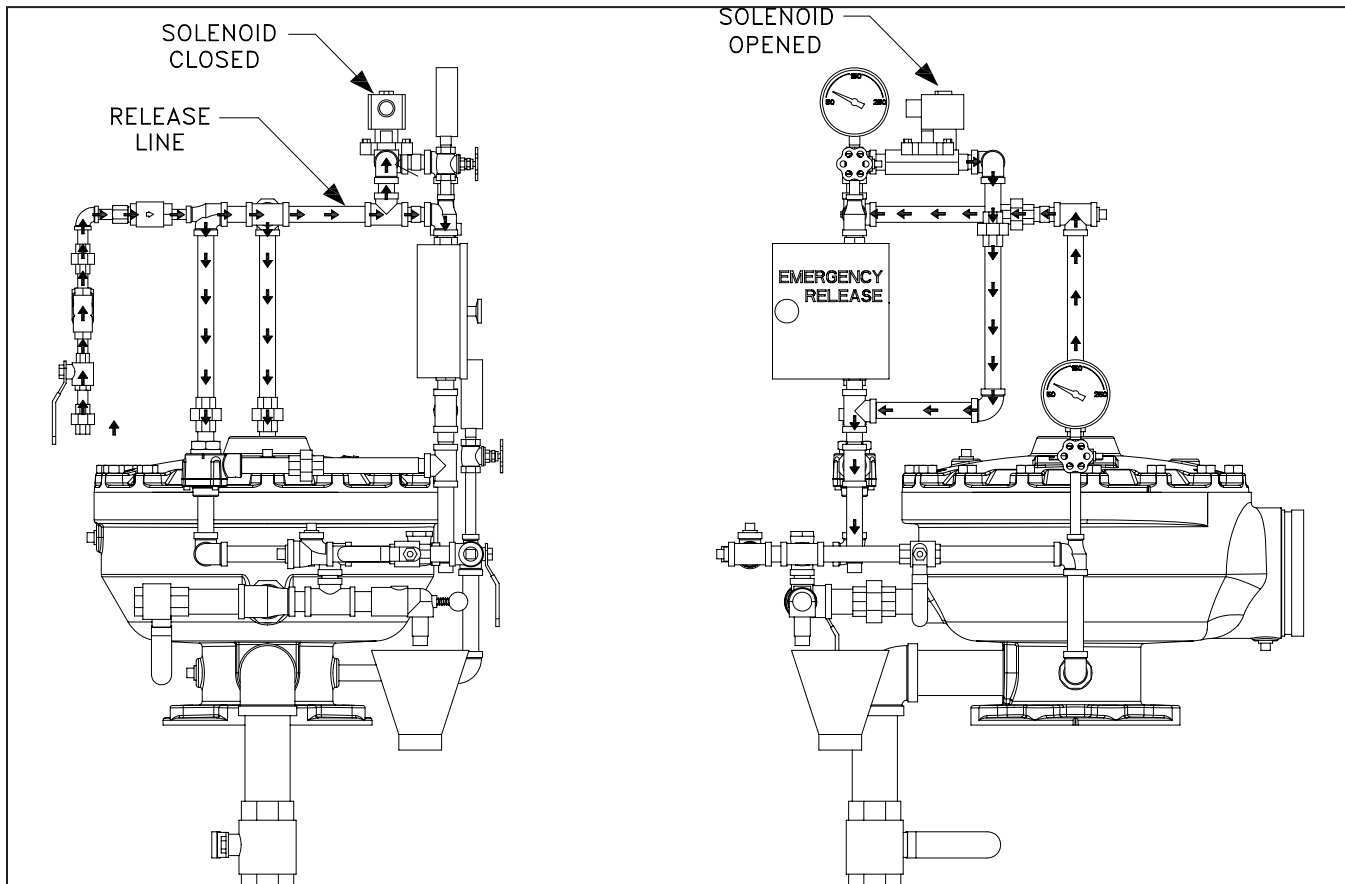
## TECHNICAL DATA

## DELUGE SPRINKLER SYSTEM

The Viking Corporation, 210 N Industrial Park Drive, Hastings MI 49058

Telephone: 269-945-9501 Technical Services 877-384-5464 Fax: 269-818-1680 Email: techsvcs@vikingcorp.com

The solenoid reacts to device actuation by opening to relieve pressure from the release line (Figure 23).



**Figure 23**

**Determine Element to be Detected:** Determine the physical change to be detected such as fixed-temperature, rate-of-temperature increase, radiation, smoke, pressure, and the level at which the detection should take place. Determine whether two or more elements shall be detected, such as fixed temperature and smoke. Determine the need for explosion-proof components. Installation and maintenance costs, however, are usually higher than comparable hydraulically or pneumatically operated systems.

**Select Appropriate Detectors:** From the manufacturer's information, determine which detectors satisfy the physical change requirements. Note the electrical characteristics of the devices chosen, the supervision capabilities, and the suitability for the application. Verify that the detector is listed and approved for the application used, and is compatible with all other components. Space in accordance with manufacturer's recommendations.

**Select Compatible Components:** Note the electrical characteristics of the solenoid valve, as it must be compatible with the system control panel and other electrical components. From the manufacturer's technical information, determine that the devices selected are compatible with each other. Observe all manufacturer's technical instructions.

**Location of Release and Pressure Switch:** The location of the solenoid valve is shown on the various system data sheets. Flow through the release must be in the direction indicated. The pressure switch in the release control unit system is located in the alarm line.

**Determine Requirements for Supervision:** Circuits that are not normally energized can be supervised by passing a small amount of current through them. This current will operate a sensing relay, but is not great enough to allow the controlled device to operate. If a break occurs in the supervised circuit, this supervisory current will be interrupted and a trouble alarm will sound. Detector circuits, release



## TECHNICAL DATA

## DELUGE SPRINKLER SYSTEM

The Viking Corporation, 210 N Industrial Park Drive, Hastings MI 49058

Telephone: 269-945-9501 Technical Services 877-384-5464 Fax: 269-818-1680 Email: techsvcs@vikingcorp.com

circuits, and alarm circuits are commonly supervised. If bell circuits with more than one bell are to be supervised, polarized bells must be used. Determine the requirements for such supervision.

**Determine Accessory or Auxiliary Device Requirements:** Often electrical detection systems will be required to sound auxiliary alarms and provide contacts for independent alarm systems. The requirements for these auxiliary services and their need for supervision should be determined and their electrical characteristics considered.

**Determine the Current Requirements of the System:** Determine the current requirements of the sum of components in the system, when it is in the set and tripped condition. Do not exceed rated capacity of the control panel used. Do not exceed the rated capacity of any system circuit.

**Consider the Power Supply and Requirements for Standby Power:** The electrical release systems requires a stable source of power. An electrically activated system does not operate automatically in the event of a total loss of power. Therefore, supervisory backup power may be required for emergency situations. The dependability of the power supply is a critical factor; with interruption of power, the control system will either trip immediately or be unable to trip, depending on its mode or configuration. A mechanical detection system can be designed to provide protection in this event. However, if available power is suspect, standby power in the form of a battery charger and suitable batteries are usually required and must be provided.

If a standby power supply is used, determine its capacity: Standby power must be provided as long as regular power is out of service. Therefore, this time is dependent upon a large number of factors, including location of the installation, the level of maintenance, the availability of maintenance, and the historical frequency and duration of power outages. A 24-hour standby capability is usually considered the minimum requirement with 100 hours usually the maximum. Multiplying the maximum system current requirements by the time requirements will give the battery capacity and battery charger requirements.

**Wire Sizes and Maximum Resistance:** Requirements are found on individual technical data sheets.

*Trimpac® Deluge Systems Controlled by Electric Release:* TRIMPAC® Model B-1 and B-1B incorporates an electric release solenoid that controls the pressurization of the priming chamber of the deluge valve. Water is supplied to the deluge valve's priming chamber from an outlet upstream of the water supply control valve. Water follows Point #1 to the TRIMPAC®, passes through the normally opened priming valve, Y strainer, 1/16" restricted orifice, and spring loaded check valve. Water is supplied to the inlet side of the normally closed solenoid valve and to the priming side of the P.O.R.V. Priming water exits the TRIMPAC® through the outlet side of the 1/2" tee supplying the P.O.R.V. and the NC solenoid valve of the TRIMPAC®, passing to the priming chamber of the deluge valve, pressurizing the deluge valve closed. (Priming pressure can be identified at the priming pressure gauge view-port on the TRIMPAC®.) Once priming pressure is present in the priming chamber of the deluge valve, the water supply control valve can be opened. Once the water supply control valve is opened, water will pressurize the inlet chamber of the deluge valve, water will exit the inlet chamber of the deluge valve and enter Point #5 of the TRIMPAC®. After water enters Point #5 of the TRIMPAC® it will pressurize the water supply pressure gauge. Water pressure will now be available on the inlet of the normally closed alarm test valve. The valve and trim assembly is now in a normal operation mode.

*Trimpac® in Fire Conditions:* A compatible electric release device (or combination of compatible electric release devices) activates which initiates a power sequence from a listed release control panel to open the normally closed solenoid valve in the TRIMPAC®. The solenoid valve opens releasing the water pressure in the deluge valve's priming chamber. Priming water is discharged from the outlet of the solenoid valve to the drain cup. Once the priming water pressure is relieved in the priming chamber of the deluge valve, water supply pressure will pass from the inlet of the deluge valve to the outlet of the deluge valve to the sprinkler piping. During deluge valve operation, water is discharged through the drain valve package to Point #4 of the TRIMPAC®. Water enters Point #4 of the TRIMPAC® to activate the water flow alarms and pressurize the sensing line of the P.O.R.V. Once the sensing side of the P.O.R.V. is pressurized, priming water will be vented from the drain end of the P.O.R.V. through Point #3 of TRIMPAC® to the drain cup.



## TECHNICAL DATA

## DELUGE SPRINKLER SYSTEM

The Viking Corporation, 210 N Industrial Park Drive, Hastings MI 49058

Telephone: 269-945-9501 Technical Services 877-384-5464 Fax: 269-818-1680 Email: techsvcs@vikingcorp.com

### V. DELUGE VALVE

#### A. Description

The Viking Deluge Valve (Figure 24) is a quick-opening, differential type flood valve used to control water flow in deluge systems. It is a quick opening differential diaphragm flood valve with only one moving part (Figure 25).

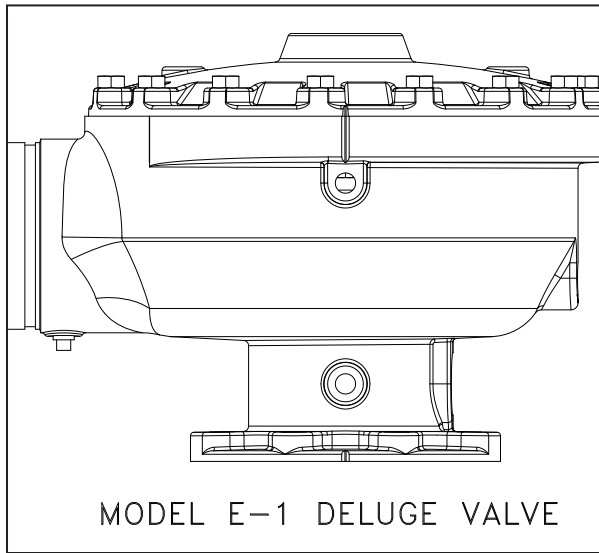


Figure 24

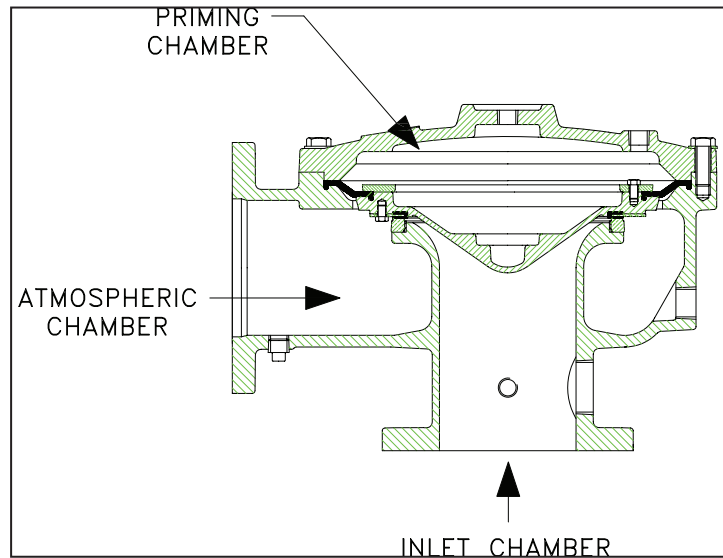


Figure 25

Viking's deluge valve is held closed by a pressure differential of over 2:1 (Figure 26), which keeps the system dry until the releases activate. The valve has a unique design which allows it to be mounted in any position with an inlet, an outlet, and a priming chamber (Figure 27).

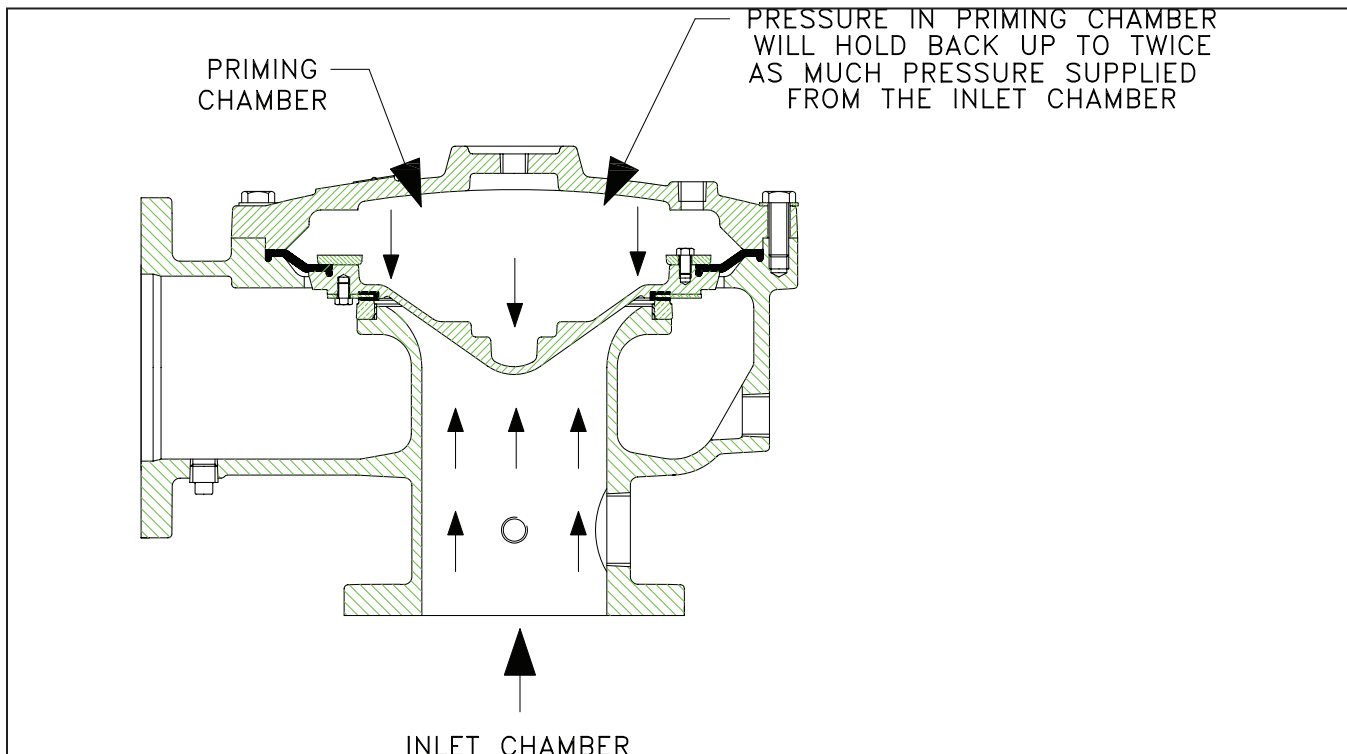


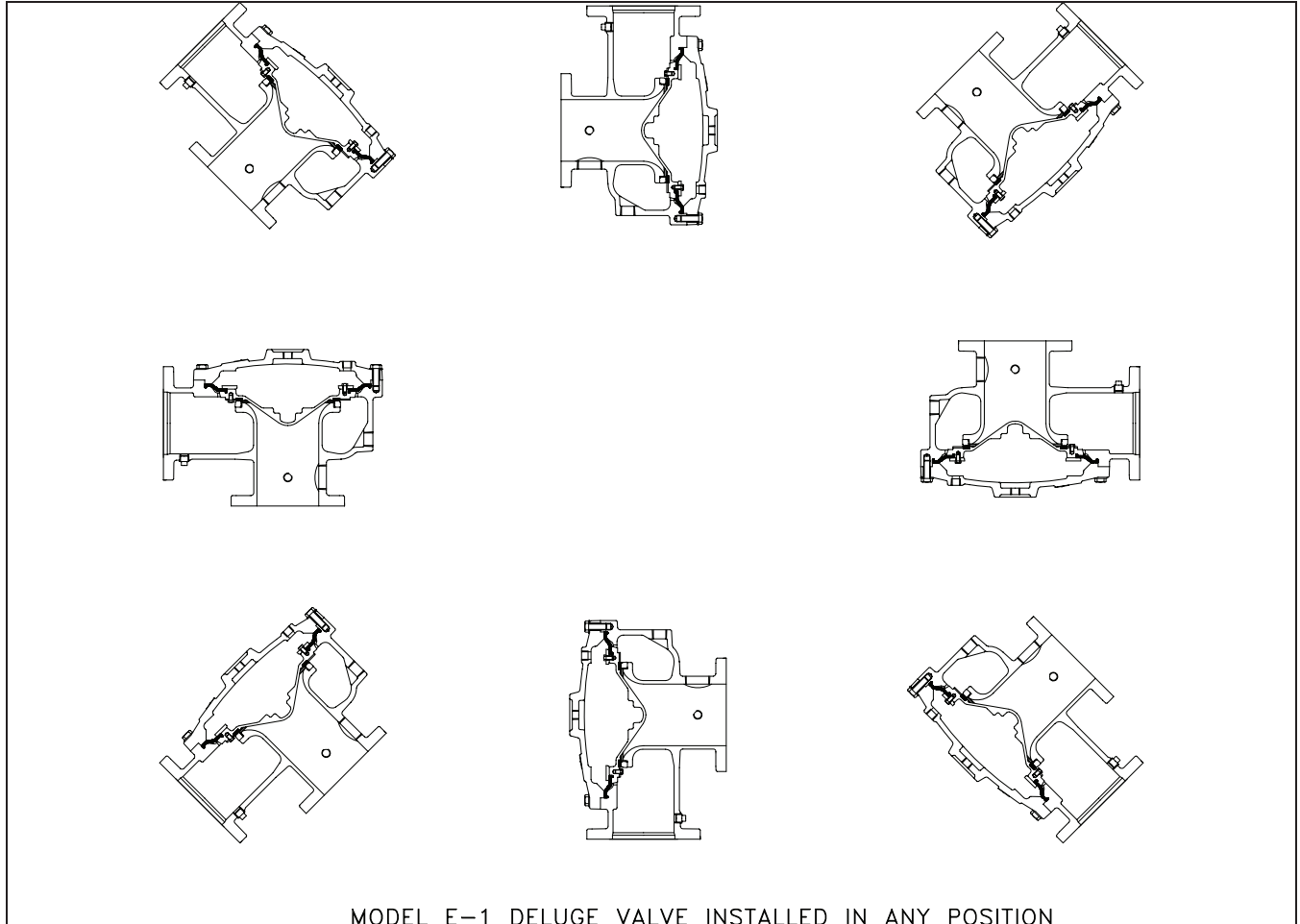
Figure 26



## TECHNICAL DATA

## DELUGE SPRINKLER SYSTEM

The Viking Corporation, 210 N Industrial Park Drive, Hastings MI 49058  
 Telephone: 269-945-9501 Technical Services 877-384-5464 Fax: 269-818-1680 Email: techsvcs@vikingcorp.com



**Figure 27**

The Viking Halar® Coated Deluge Valve is manufactured with specially coated components. The body and cover of the valve is coated inside and outside with Halar® coating consisting of ethylene chlorotrifluoroethylene (ECTFE). The coating makes the valve suitable for use in corrosive environments similar to those found on offshore platforms and many industrial chemical facilities. The coated valve may be used to control water flow in deluge systems supplied by brackish or salt water when operation is controlled by fixed temperature hydraulic release systems. Also, the Viking coated deluge valve has been satisfactorily evaluated as a Foam Concentrate Control Valve for use with AFFF or ATC foam in fixed foam/water sprinkler systems.

### B. Accessories

1. A conventional trim package for use with the deluge valve. The trim package includes the valve accessory package and the fittings and nipples shown on the Viking deluge valve conventional trim chart for the valve used. Trim charts are provided in trim packages and the *Viking Engineering and Design Data* book. For optional factory assembled "modular" trim packages, refer to Viking's price book or contact the manufacturer.
2. A deluge valve accessory package includes required trim components. This package is needed when Viking trim packages are not used.
3. A special trim package is available for use when the Halar® Coated Deluge Valve is used as a FOAM CONCENTRATE CONTROL VALVE for AFFF or ATC Foam Concentrate. See the Viking Foam Engineering and Design Data book.

Additional accessories are available and may be required for system operation or supervision. Refer to the system description and technical data for complete operating trim requirements for the system used.



## TECHNICAL DATA

## DELUGE SPRINKLER SYSTEM

The Viking Corporation, 210 N Industrial Park Drive, Hastings MI 49058

Telephone: 269-945-9501 Technical Services 877-384-5464 Fax: 269-818-1680 Email: techsvcs@vikingcorp.com

### C. Operation

The Viking deluge valve has an inlet chamber, an outlet chamber and a priming chamber. The inlet chamber and outlet chamber are separated from the priming chamber by the clapper and diaphragm.

#### In the Set Condition

The deluge valve priming chamber has a combined priming water inlet and outlet to the activating devices (Figure 28). A strainer, a check valve, and a restricted orifice are mounted on the inlet piping to the priming chamber (Figure 29).

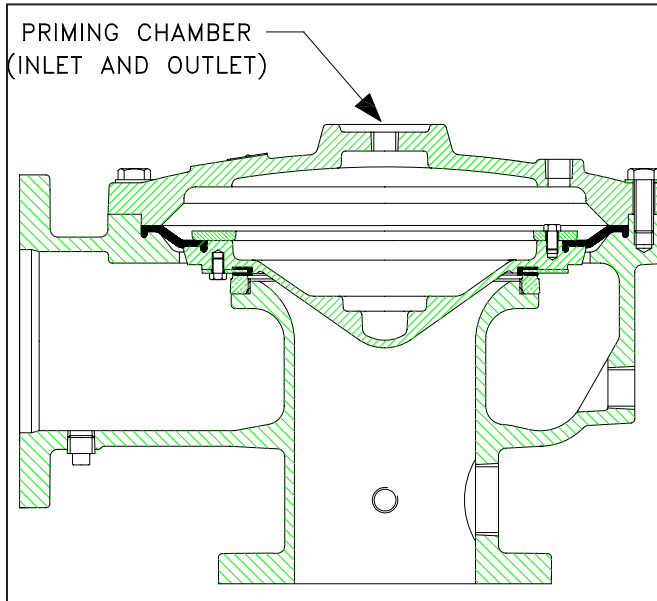


Figure 28

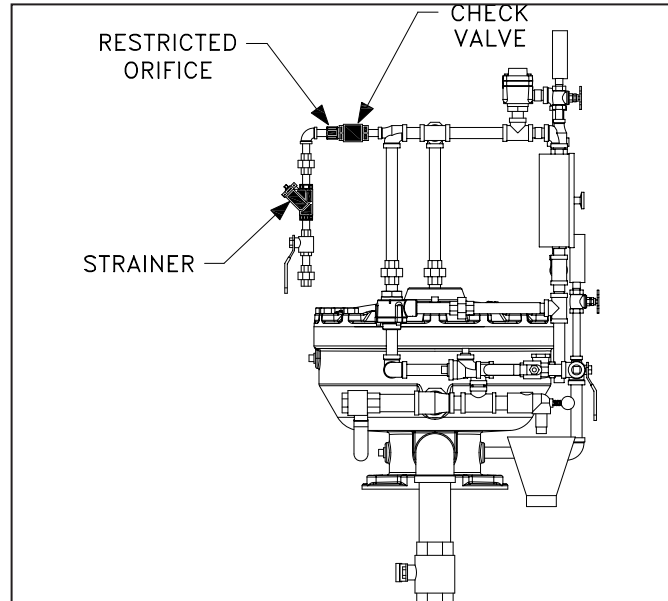


Figure 29

The restricted orifice is 1/8" and is the same for all size deluge valves, from 1-1/2" to 6" valves. System pressure is supplied to the priming chamber through a restricted priming line (trim) (Figure 30) equipped with a check valve.

System water supply pressure trapped in the priming chamber holds the valve clapper closed, keeping the outlet chamber and system piping dry. Pressure enters the priming chamber through a restricted priming line (Figure 31), holding the clapper on its seat. A pressure gauge is also supplied by this piping (Figure 32). The inlet has a main drain connection and an alarm test connection (Figure 33). The deluge valve prevents water from entering the system piping until required.

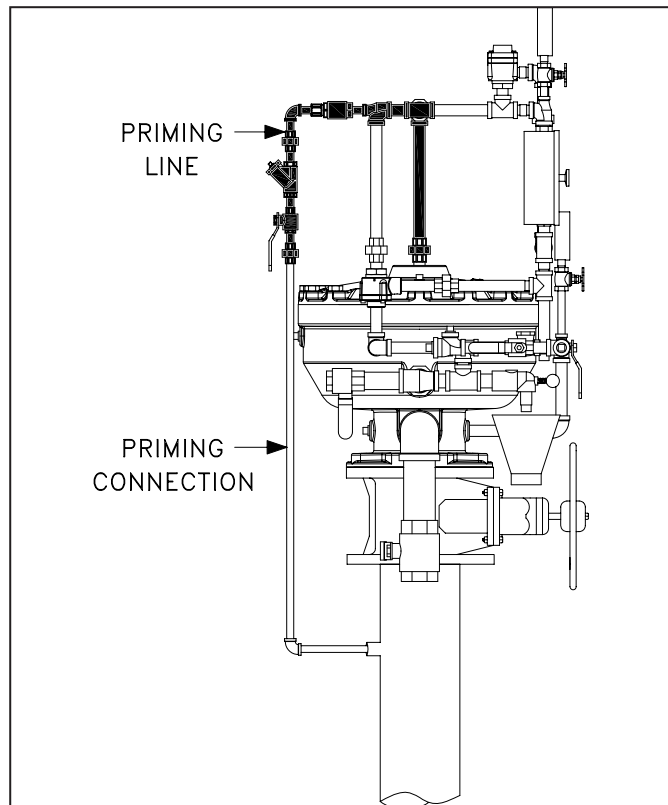


Figure 30



TECHNICAL DATA

DELUGE SPRINKLER SYSTEM

The Viking Corporation, 210 N Industrial Park Drive, Hastings MI 49058  
Telephone: 269-945-9501 Technical Services 877-384-5464 Fax: 269-818-1680 Email: techsvcs@vikingcorp.com

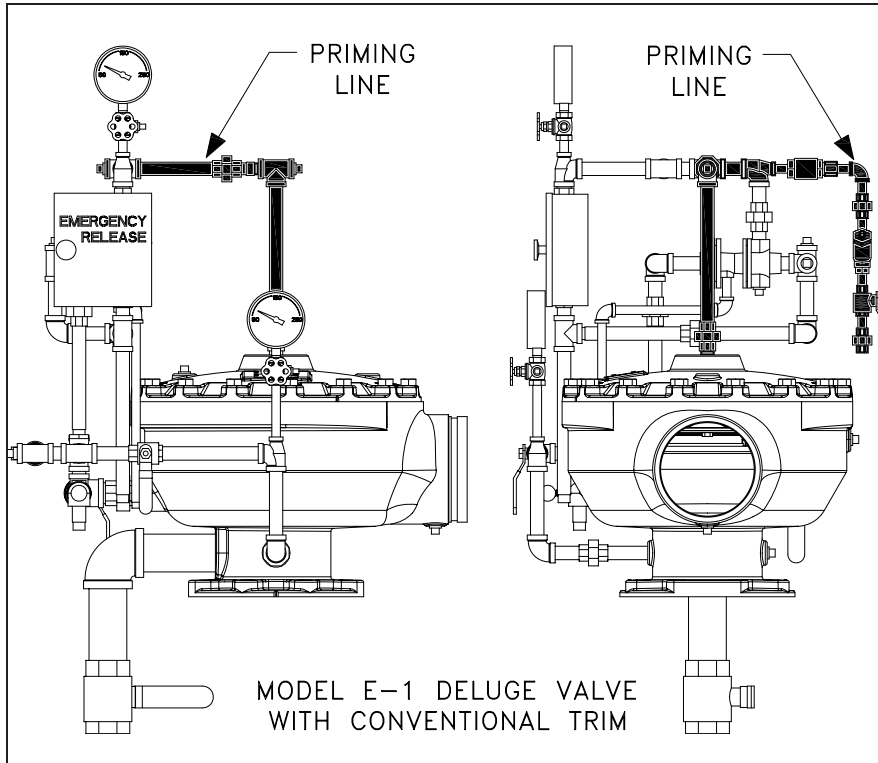


Figure 31

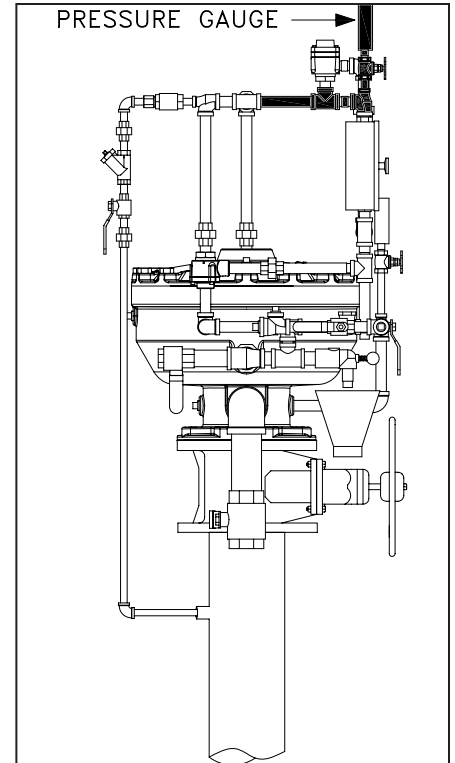


Figure 32

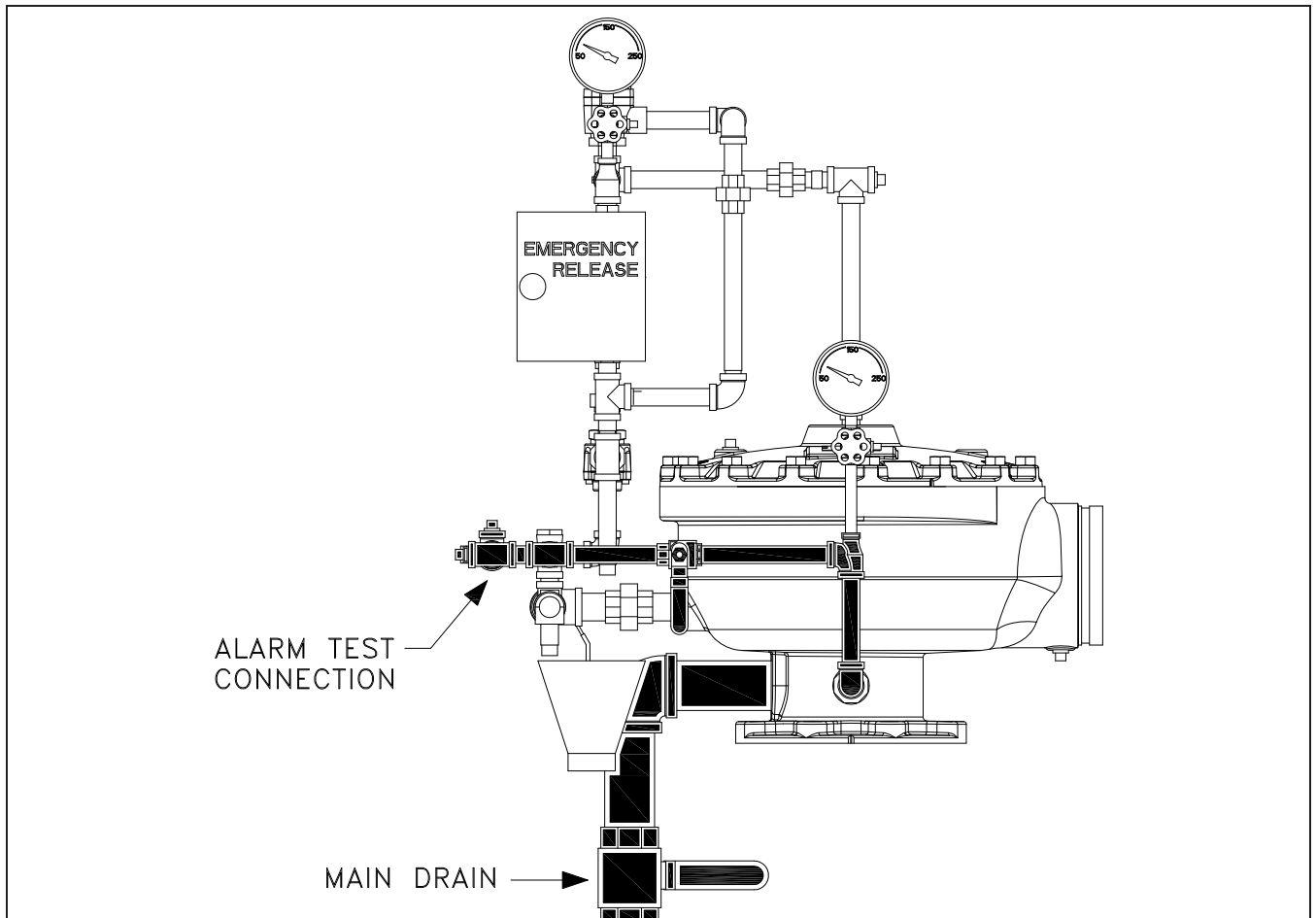


Figure 33

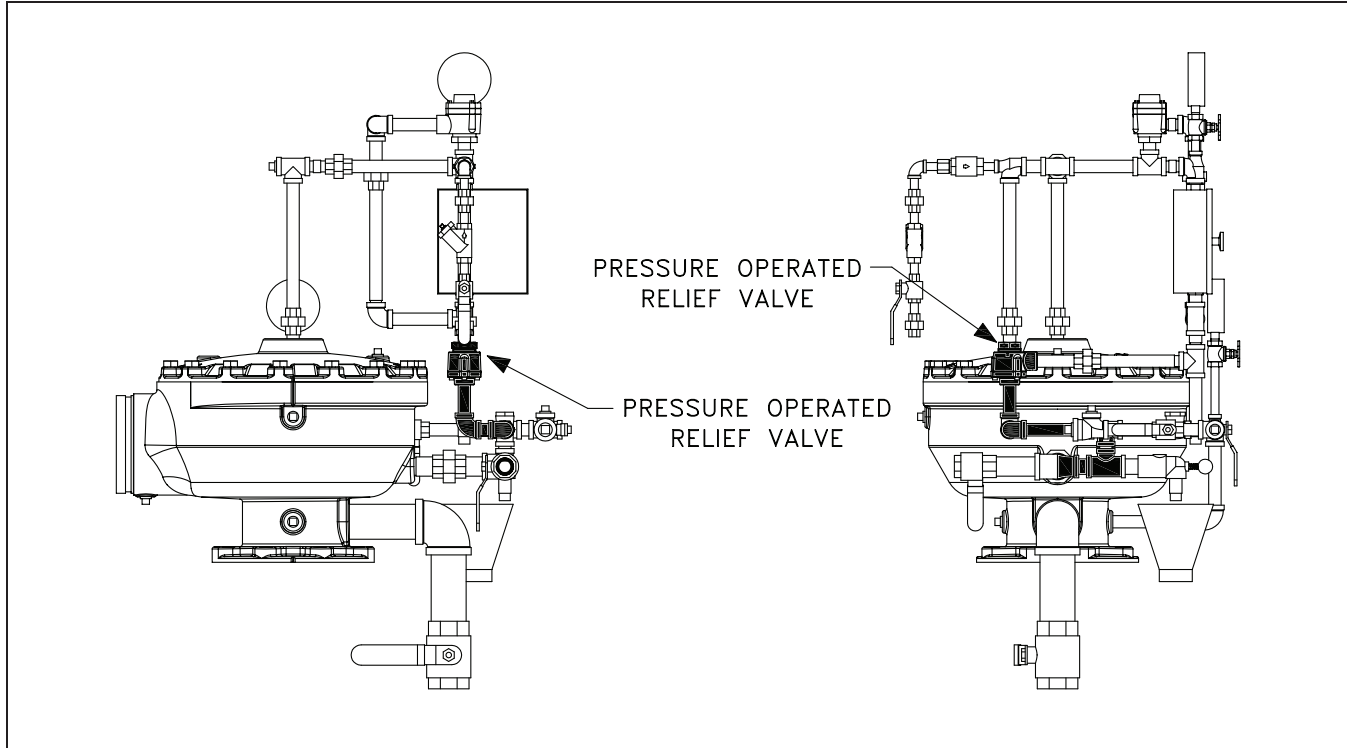


## TECHNICAL DATA

## DELUGE SPRINKLER SYSTEM

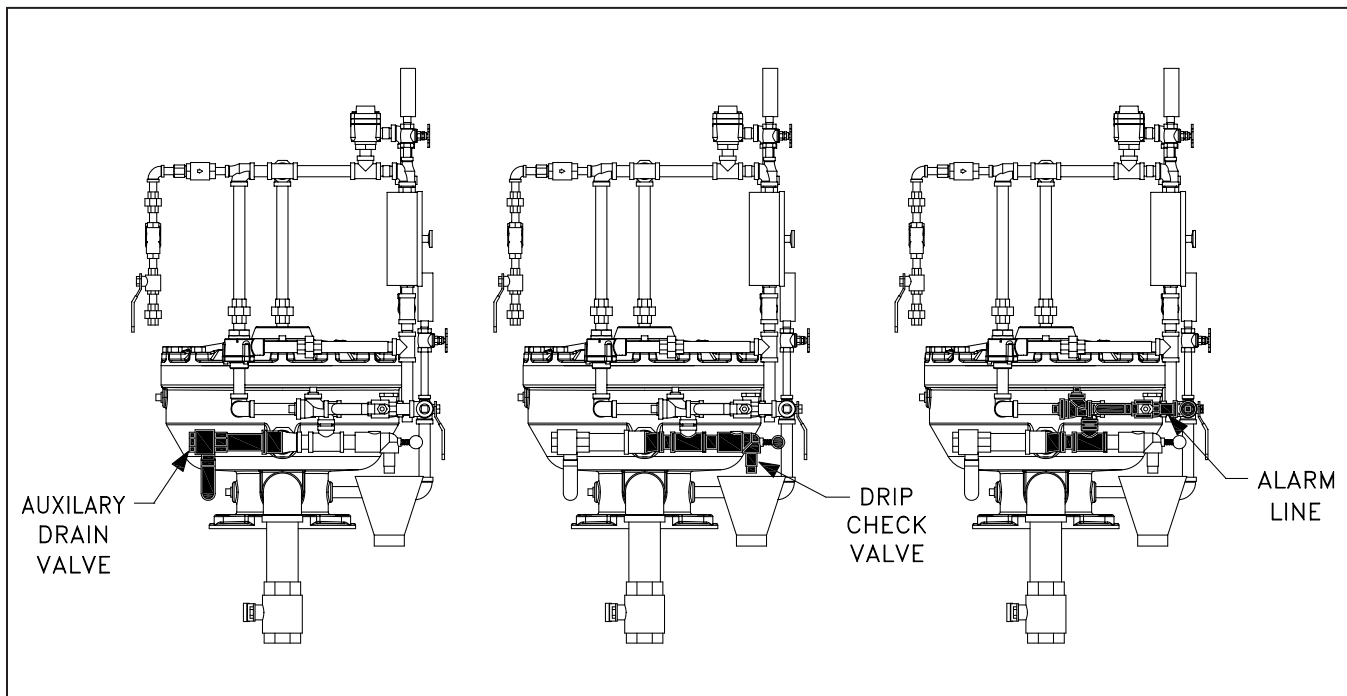
The Viking Corporation, 210 N Industrial Park Drive, Hastings MI 49058

Telephone: 269-945-9501 Technical Services 877-384-5464 Fax: 269-818-1680 Email: techsvcs@vikingcorp.com



**Figure 34**

The outlet side of the deluge valve has a 1" connection to piping to a pressure operated relief valve (Figure 34). This connection also supplies the alarm line plus a drip check valve, auxiliary drain, and associated trim (Figure 35).



**Figure 35**

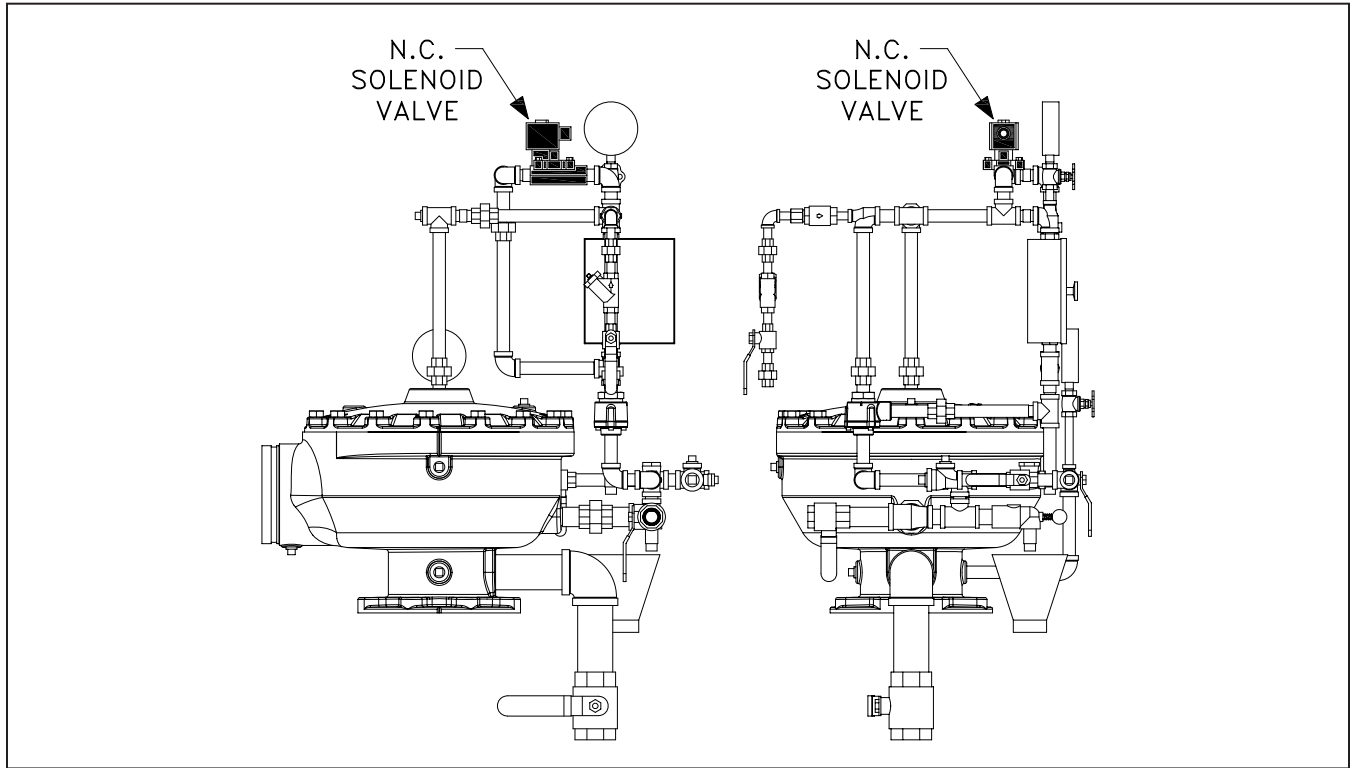


	<b>TECHNICAL DATA</b>	<b>DELUGE SPRINKLER SYSTEM</b>
--	-----------------------	--------------------------------

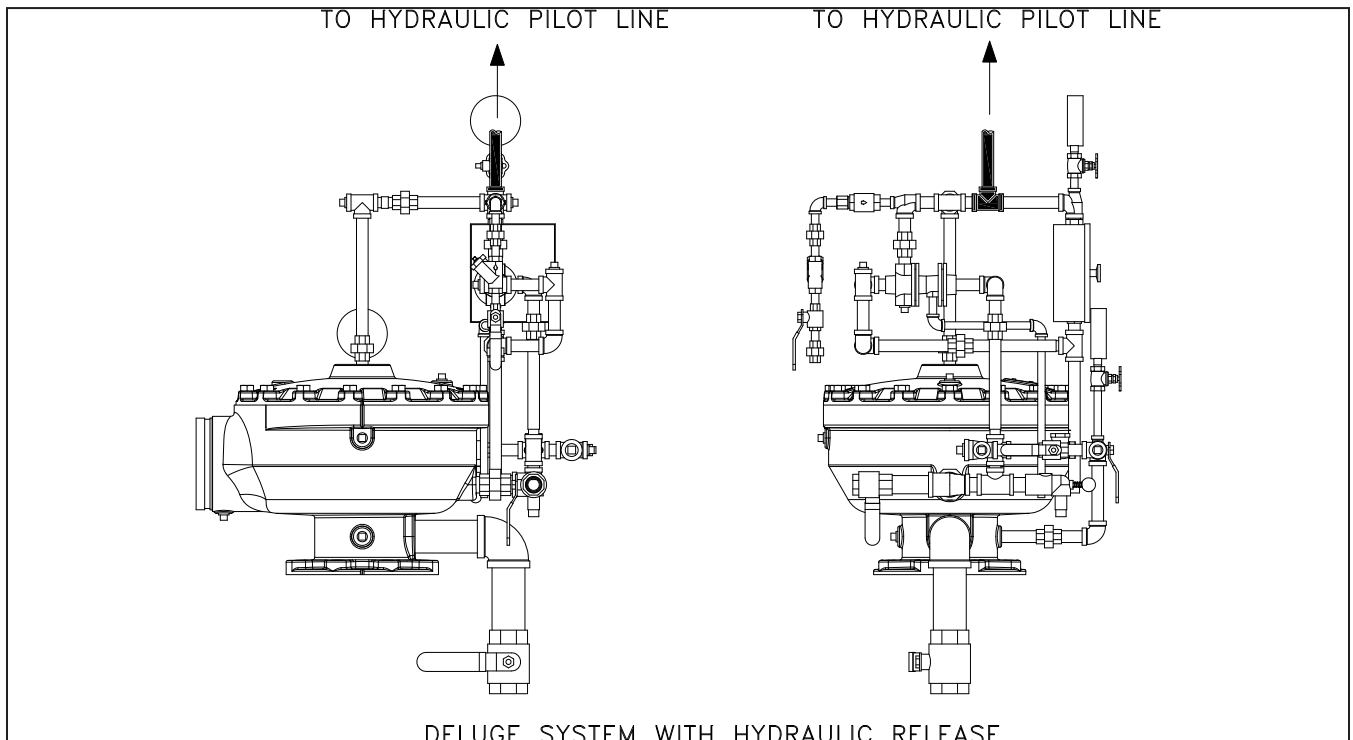
The Viking Corporation, 210 N Industrial Park Drive, Hastings MI 49058  
 Telephone: 269-945-9501 Technical Services 877-384-5464 Fax: 269-818-1680 Email: techsvcs@vikingcorp.com

In Fire Conditions

Electric, hydraulic, or pneumatic release systems can be used to relieve priming chamber pressure (Figures 36-38). When the release system operates, pressure is released from the priming chamber faster than it is supplied through the restricted priming line. Water supply pressure in the inlet chamber forces the clapper off the seat, allowing water to flow through the outlet into the system piping, activating alarm devices.



**Figure 36**



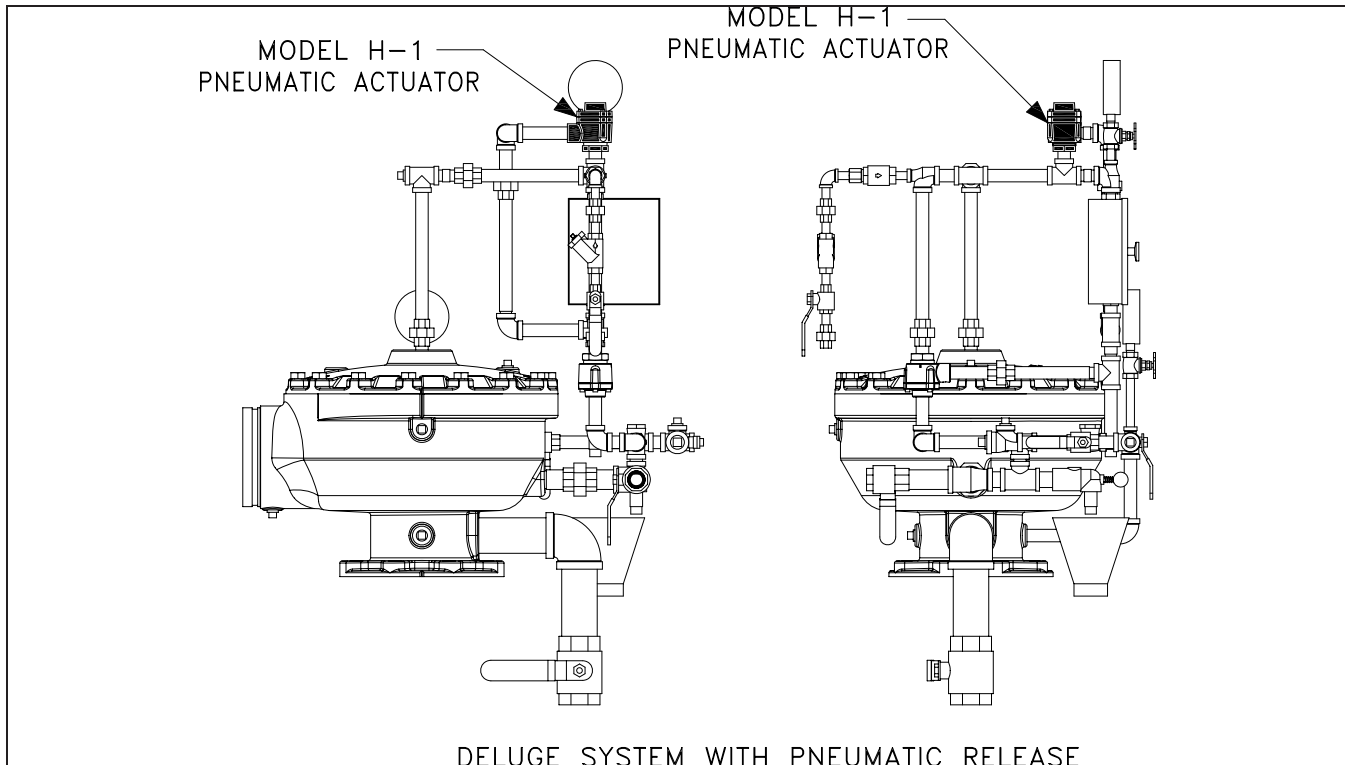
**Figure 37**



## TECHNICAL DATA

## DELUGE SPRINKLER SYSTEM

The Viking Corporation, 210 N Industrial Park Drive, Hastings MI 49058  
 Telephone: 269-945-9501 Technical Services 877-384-5464 Fax: 269-818-1680 Email: techsvcs@vikingcorp.com



**Figure 38**

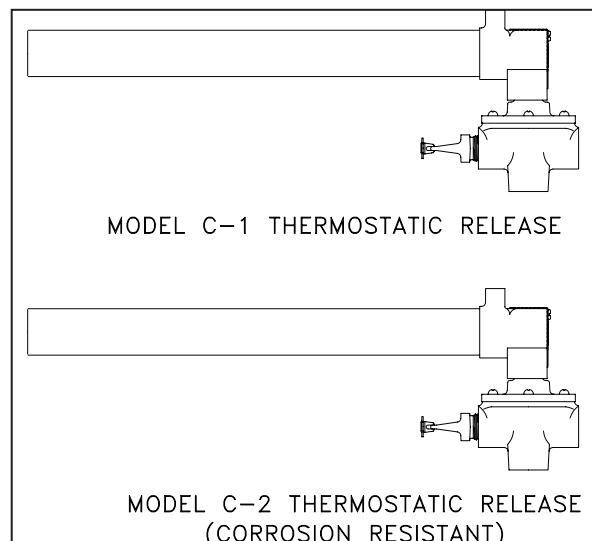
### Trouble Conditions

If the detection system or hydraulic release system operates due to mechanical damage or malfunction, the deluge valve will open. Similarly, in the event of an air supply failure and slow leakage of air from the pneumatic release system, alarms connected to air supervisory switch will signal a low air pressure condition. Failure to restore air supply to the pneumatic release system will result in operation of the pneumatic actuator and the deluge valve will open. Water will flow from any open sprinklers and/or spray nozzles on the system. Water motor alarm and alarms connected to alarm pressure switch will activate.

## VI. THERMOSTATIC RELEASES

### A. Description

Viking Model C-1 and C-2 Thermostatic Releases (Figure 39) are rate-of-rise releasing devices for use on hydraulic and pneumatic release systems controlling operation of Viking deluge valves on deluge systems. When subjected to a temperature rise greater than 15° (8.3 °C) per minute, the release opens to allow pressure in the release system to escape. The operating principle is based on metals expanding at unequal rates. The unit may also be equipped with a fixed temperature release that will release the system at a preset temperature regardless of the rate of temperature increase. Model C-1 and C-2 Thermostatic Releases may be used indoors or outdoors on either hydraulic or pneumatic release systems. The Model C-2 Thermostatic Release may be used in corrosive environments where sea water atmospheres are present.



**Figure 39**

**TECHNICAL DATA****DELUGE SPRINKLER  
SYSTEM**

The Viking Corporation, 210 N Industrial Park Drive, Hastings MI 49058

Telephone: 269-945-9501 Technical Services 877-384-5464 Fax: 269-818-1680 Email: techsvcs@vikingcorp.com

Avoid installing thermostatic releases in environments subject to large, rapid temperature fluctuations under normal conditions. When in doubt, consult the manufacturer.

**B. Operation**

Pressurized air, nitrogen, or water supplied to the release system flows into the inlet and through a small hole in diaphragm. The pressure is trapped above diaphragm by the closed schrader valve, forcing clapper to close against seat. When the thermostatic release is subjected to a temperature rise greater than 15 °F (8.3 °C) per minute, the element tube expands more rapidly than the rod element to exert a pulling force on lever arm.

As lever arm pivots on pivot pin, socket screw depresses the operating stem of schrader valve. When the schrader valve stem is depressed, it rapidly vents pressure from above diaphragm faster than the pressure can be replaced through the small hole in the diaphragm. Higher pressure in the release system pushes clapper off the seat and is vented to atmosphere through the drain outlet.

**C. Maintenance**

Viking thermostatic releases must be kept free of foreign matter, corrosive atmospheres, contaminated water supplies, and any condition that could impair its operation or damage the device.

Note: Installation of replacement sub-assemblies or a replacement schrader valve core requires disassembly and adjustment of the thermostatic release. Refer to Disassembly below. Viking tool kit Part No. 01714A is required. Note: The tube element and rod element are factory set. They are not adjustable and cannot be replaced.

**D. Inspection**

Visual inspection of thermostatic releases is recommended semi-annually and/or any time changes are made to the building, occupancy, or environment that might affect operation of the release.

1. Verify that the bottom drain outlet is not plugged. If operation detectors have been installed, verify that the plastic cap is in place.
2. Verify that no changes have been made to the building, occupancy, or any other conditions that would affect operation of the unit.
3. Check for signs of mechanical damage, and/or corrosive activity. If detected, perform maintenance as required, or if necessary, replace the device. Painted thermostatic releases must be replaced.

**E. Operational Test**

Each thermostatic release should be operated annually. An acceptable heat source is required (refer to step 5 below). Also, refer to valve and system data.

1. Notify the Authority Having Jurisdiction and those in the area affected by the test.
2. To prevent operation of deluge systems, close the main water supply control valve. (See WARNING in MAINTENANCE paragraph above.)
3. Keep the priming valve open.
4. For pneumatic release systems, keep the air supply to the release system in service.
  - a. Low-air alarms controlled by air supervisory switches installed on the pneumatic release system will activate during the test unless they are taken out of service during testing.
5. Place an acceptable heat source over or next to the element tube. An acceptable heat source is one that will evenly distribute sufficient heat over the element tube to simulate a rise in ambient temperature greater than 15 °F (8.3 °C) per minute. A hot cloth wrapped around the element tube is an example of an acceptable heat source. DO NOT use a torch directly on the element tube.
  - a. If the thermostatic release is equipped with a fixed temperature release, use care not to heat the fixed temperature release above the recommended maximum ambient temperature for the temperature rating used.



## TECHNICAL DATA

## DELUGE SPRINKLER SYSTEM

The Viking Corporation, 210 N Industrial Park Drive, Hastings MI 49058

Telephone: 269-945-9501 Technical Services 877-384-5464 Fax: 269-818-1680 Email: techsvcs@vikingcorp.com

- b. The thermostatic release must be protected from mechanical damage. If the element tube becomes dented or bent, the release must be replaced.
6. Verify that the thermostatic release operates in an acceptable period of time.
  - a. On hydraulic release systems, water will flow from the drain outlet on the bottom of the thermostatic release.
  - b. On pneumatic release systems, air will flow from the drain outlet on the bottom of the thermostatic release. Low-air alarms may activate unless they have been taken out of service for the test.
7. After the release operates:
  - a. Remove the heat source.
  - b. Allow the thermostatic release to cool and reset.
  - c. Allow the release system to re-pressurize.
8. Repeat steps 5 through 7 for each thermostatic release being tested.
9. When testing is complete:
  - a. For pneumatic release systems: If low-air alarms were taken out of service for the test, return them to service.
10. Place the system back in service. Refer to Viking system data for the system used and Viking technical data for the valve used.
  - a. Verify that all valves are in their normal operating position.
11. Notify the Authority Having Jurisdiction and those in the area affected by the test that the system is back in service.

### F. Disassembly (See WARNING in MAINTENANCE)

To install replacement diaphragm assembly, spring, or body assembly:

1. To prevent operation of deluge systems, close the main water supply control valve.
2. De-pressurize the release system.
3. Using a screw driver, remove six screws. Body will separate from cover (Figure 40).
4. Spring, seal ring and diaphragm assembly may be removed (Figure 41).
5. Install the replacement part or sub-assembly needed.
6. Reassemble the unit.
7. Restore pressure to release system. Verify there are no leaks from the release.
8. Perform OPERATIONAL TEST described in MAINTENANCE to verify proper operation of the thermostatic release.

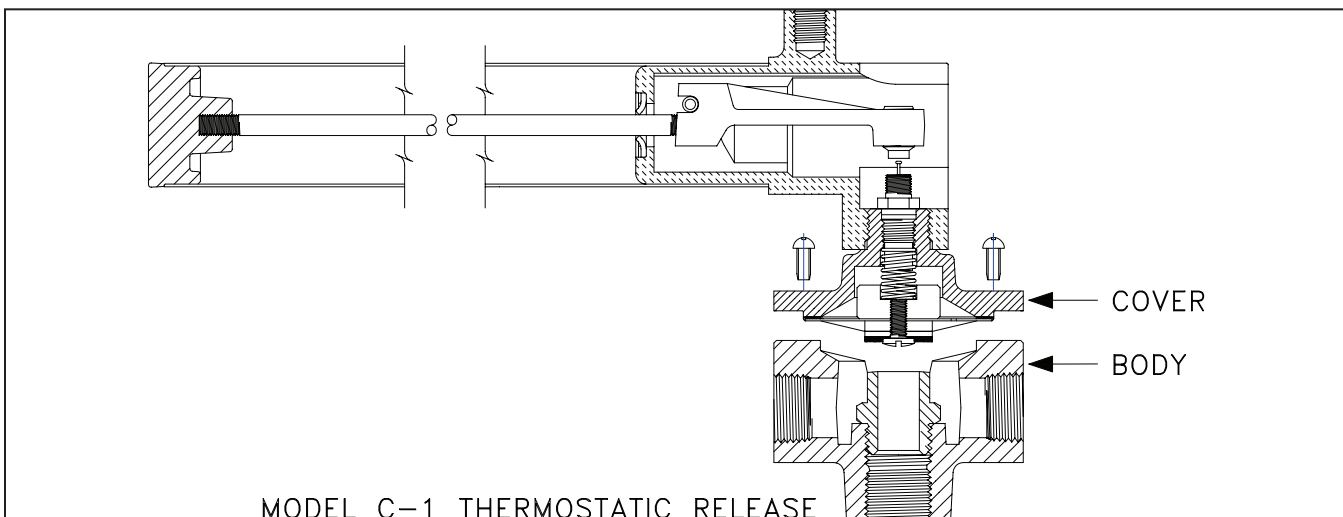


Figure 40



TECHNICAL DATA

DELUGE SPRINKLER SYSTEM

The Viking Corporation, 210 N Industrial Park Drive, Hastings MI 49058  
 Telephone: 269-945-9501 Technical Services 877-384-5464 Fax: 269-818-1680 Email: techsvcs@vikingcorp.com

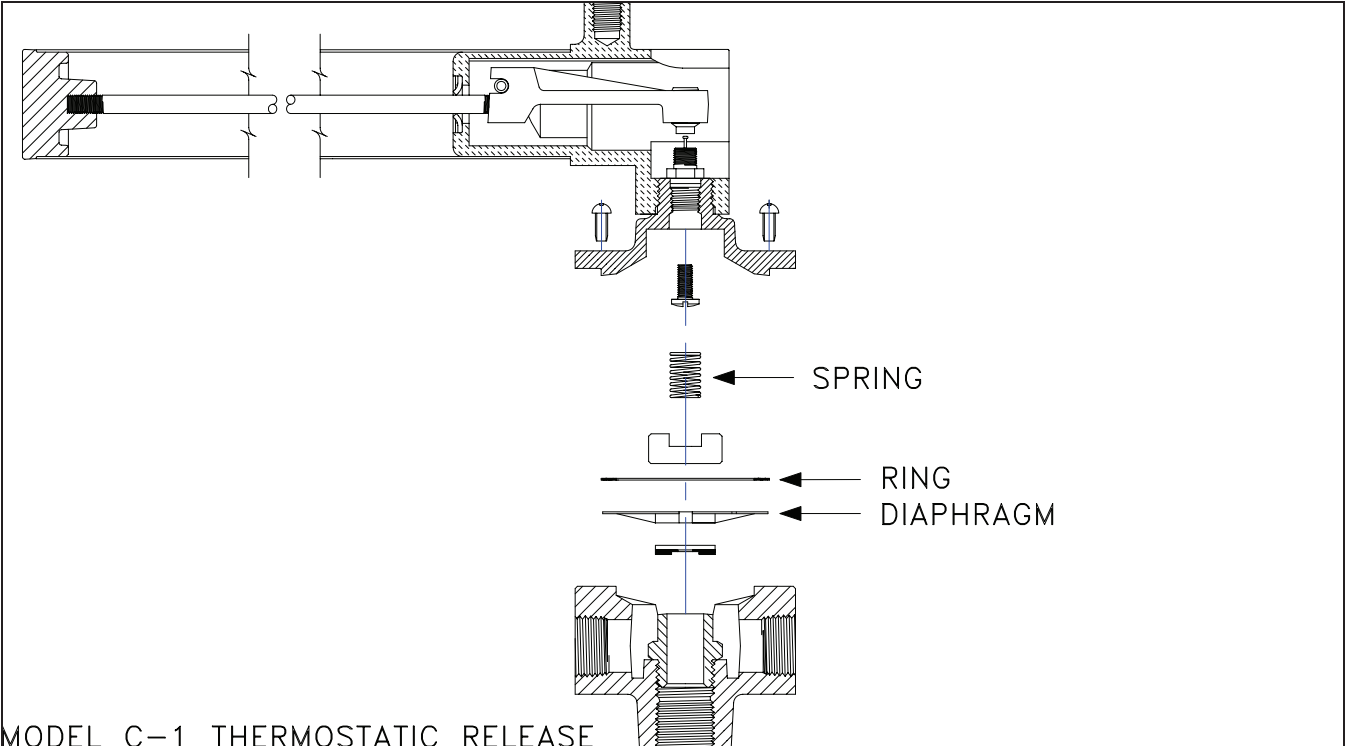


Figure 41

- a. To prevent operation of deluge systems, close the main water supply control valve.
- b. De-pressurize the release system.
- c. Using a screw driver, remove two screws and cover (Figure 42).

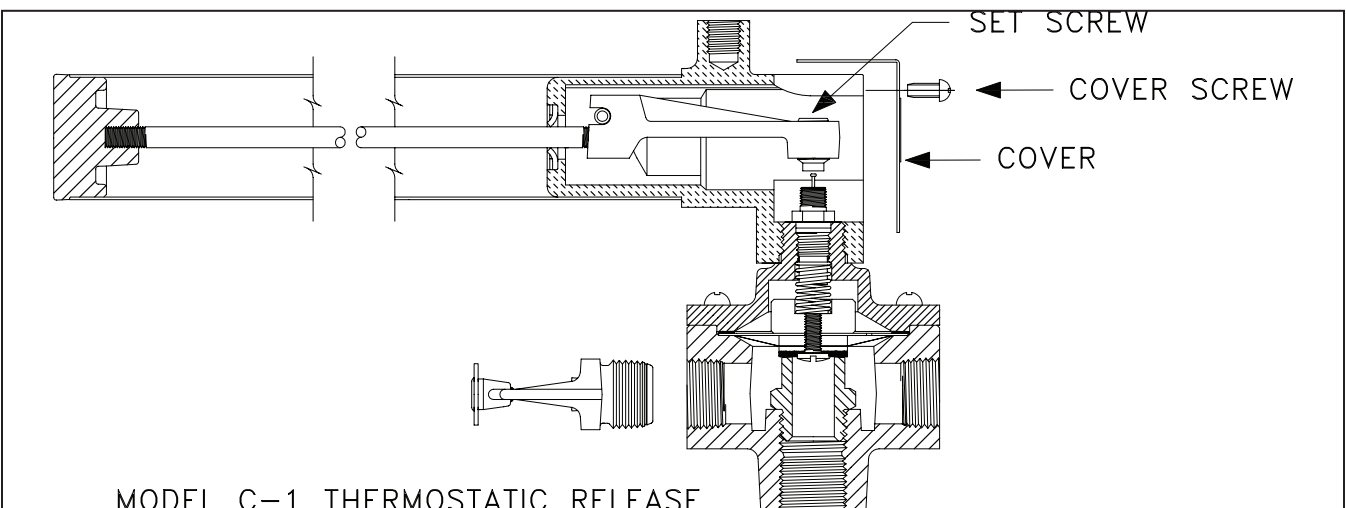


Figure 42



## TECHNICAL DATA

## DELUGE SPRINKLER SYSTEM

The Viking Corporation, 210 N Industrial Park Drive, Hastings MI 49058

Telephone: 269-945-9501 Technical Services 877-384-5464 Fax: 269-818-1680 Email: techsvcs@vikingcorp.com

- d. Use the 3/16" (4.76 mm) Allen wrench provided in tool kit (Part No. 01714A) to:
  - i. Remove set screw (Figure 43).
  - ii. Remove valve core.
- e. Install replacement valve core.
- f. Perform ADJUSTMENT steps 1-11.

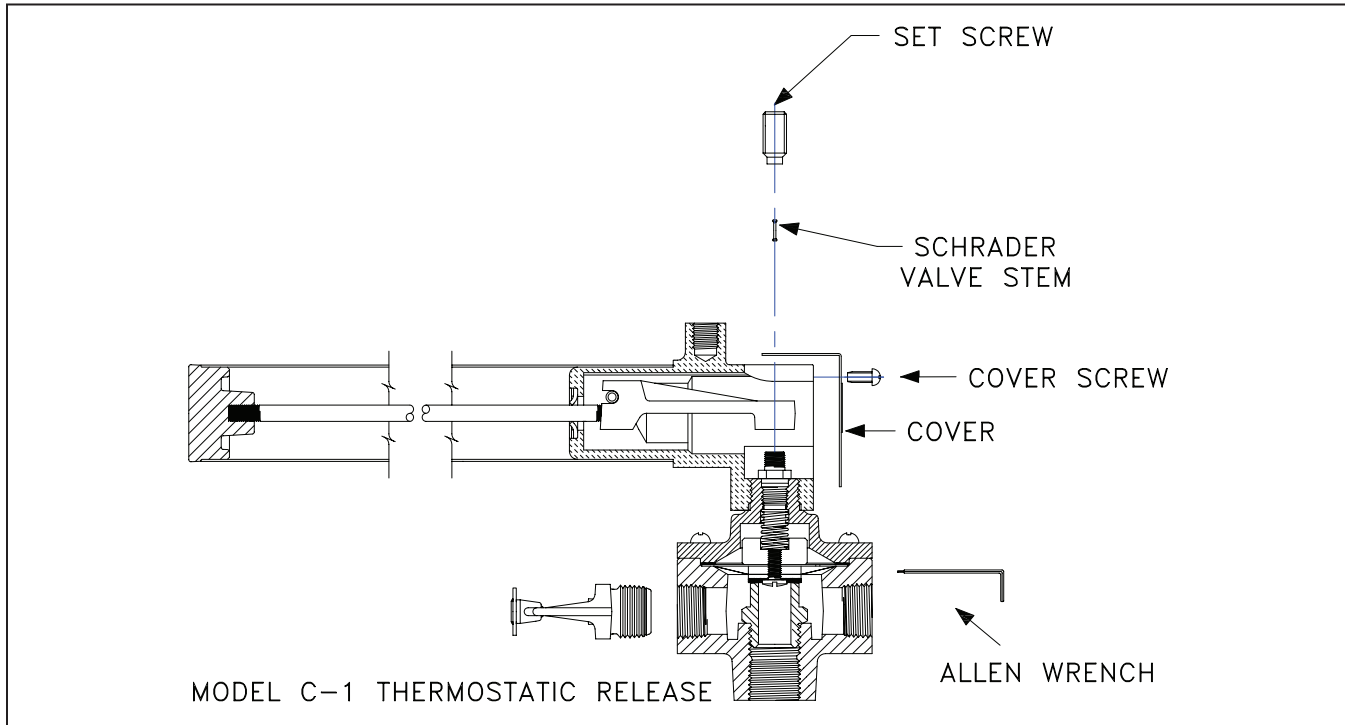


Figure 43

### G. Adjustment

Note: Viking Model C-1 Thermostatic Releases are preset with a .025" gap.

1. Verify that the main water supply control valve of the deluge system is closed.
2. Allow the thermostatic release to adjust to ambient temperature of the area where the adjustment will be performed (60 minutes minimum).

While performing the following adjustment steps, DO NOT place hands on element tube to ensure that the temperature of the tube is not altered.

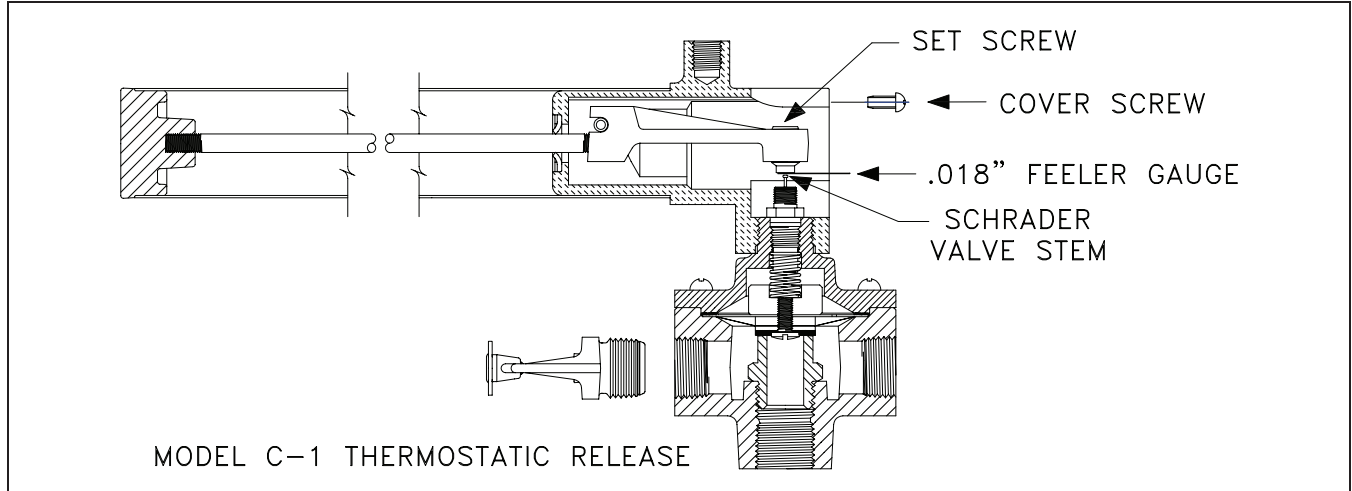
3. Pressurize the release line inlet:
  - a. For pneumatic release systems, pressurize to 30 PSI (2.1 bar) air or nitrogen pressure for system water pressures up to 175 PSI (12.1 bar), or 50 PSI (3.4 bar) air or nitrogen pressure for system water pressures up to 250 PSI (17.2 bar).
  - b. For hydraulic release systems, pressurize to 175 PSI (12.1 bar) or 250 PSI (17.2 bar) water pressure.
4. Using a screw driver, remove two screws and cover (Figure 42).
5. Use the 3/16" (4.76 mm) Allen wrench provided in tool kit (Part No. 01714A) to loosen set screw .
6. Insert the 0.025" (0.635 mm) feeler gauge (provided in tool kit Part No. 01714A) between set screw and schrader valve core (Figure 44).



## TECHNICAL DATA

## DELUGE SPRINKLER SYSTEM

The Viking Corporation, 210 N Industrial Park Drive, Hastings MI 49058  
 Telephone: 269-945-9501 Technical Services 877-384-5464 Fax: 269-818-1680 Email: techsvcs@vikingcorp.com



**Figure 44**

7. Tighten set screw until the release operates.
8. Remove the feeler gauge. The release is set.
9. Reinstall cover and screws.
10. Restore pressure to the release system:
  - a. Verify there are no leaks from the release.
11. Perform OPERATIONAL TEST described in MAINTENANCE to verify proper operation of the thermostatic release.

## VII. FIXED TEMPERATURE RELEASE

### A. Description

The Viking MicrofastHP® Fixed Temperature Release is a fixed-temperature, heat-responsive device. It is designed for use on pilot line release systems to activate deluge systems. The fixed temperature release is equipped with a 3 mm glass bulb. The special Polyester and Teflon® coatings are listed as corrosion-resistant finishes and provide protection against many corrosive environments. The fixed temperature release design closely resembles the Model M frame-style sprinkler design, but is easily identified by its special listing information plate. This is important when fixed-temperature releases are installed along with sprinklers below ceilings on concealed systems.

### B. Operation

During fire conditions, the heat-sensitive liquid in the glass bulb expands, causing the bulb to shatter, releasing the pip-cap and sealing spring assembly. This causes an opening in the pilot line and releases the pressure (air, nitrogen, or water), allowing the deluge system to operate.

### C. Maintenance

1. Fixed temperature releases must be inspected on a regular basis for corrosion, mechanical damage, obstructions, paint, etc. The frequency of inspections may vary due to corrosive atmospheres, water supplies, and activity around the device. Adequate heat must be maintained around the fixed temperature release and release piping system.

**TECHNICAL DATA****DELUGE SPRINKLER  
SYSTEM**

The Viking Corporation, 210 N Industrial Park Drive, Hastings MI 49058

Telephone: 269-945-9501 Technical Services 877-384-5464 Fax: 269-818-1680 Email: techsvcs@vikingcorp.com

2. Fixed temperature releases that have been field painted, caulked, or mechanically damaged must be replaced immediately. Any fixed temperature release showing signs of corrosion shall be tested and/or replaced immediately as required. Fixed temperature releases that are 20 years old shall be tested and/or replaced immediately as required. Consult accepted installation standards (e.g., NFPA 25), approving agencies, and Authorities Having Jurisdiction, as different minimum testing periods may be required. Fixed temperature releases that have operated cannot be reassembled or re-used, but must be replaced. When replacing fixed temperature releases, always use new units.
3. Nothing should be hung from, attached to, or otherwise obstruct the travel of heat to the fixed temperature release from any point within its listed area of coverage. Immediately remove all obstructions or, if necessary, install additional fixed temperature releases.
4. When replacing existing fixed temperature releases, the system must be removed from service. Refer to the appropriate system description and/or valve instructions. Prior to removing the system from service, notify all Authorities Having Jurisdiction. Consideration should be given to employment of a fire patrol in the effected area.
  - a. Remove the system from service, relieving all pressure (air, nitrogen, or water) on the release line piping.
  - b. Drain water from hydraulic release lines and remove any moisture present in pneumatic release lines.
  - c. Using the special wrench (Part No. 10896), remove the old fixed temperature release, and install the new unit. Care must be taken to ensure that the replacement unit has the proper temperature rating. A fully stocked sprinkler equipment cabinet should be provided for this purpose.
  - d. Place the system back in service and secure all valves. Check for and repair all leaks.
5. Sprinkler systems that have been subject to fire must be returned to service as soon as possible. The entire system must be inspected for damage and repaired or replaced as necessary. Sprinklers and fixed temperature releases that have been exposed to corrosive products of combustion or high ambient temperatures, but have not operated, should be replaced. Refer to the Authority Having Jurisdiction for minimum replacement requirements.

## VIII. PNEUMATIC ACTUATOR

### A. Description

The Viking Pneumatic Actuator is a spring loaded to open, rolling diaphragm, piston operated valve. It is used wherever a separation is required between the detection and operating systems. The pneumatic actuator is a required component on systems using pneumatic detection to provide the separation between the air in the detection system and the water in the valve operating trim.

The Model H-1 Pneumatic Actuator is listed and approved for use on Viking pneumatic release systems. The Model R-1 Pneumatic Actuator is similar to the Model H-1, except some components are specially plated for additional corrosion resistance.

### B. Operation

The Viking pneumatic actuator has an inlet, outlet and priming chamber. When pressure is applied to the priming chamber, the rolling diaphragm and piston assembly moves, constricting the spring and sealing the inlet from the outlet. Pressure can then be applied to the inlet. Due to the differential design, a small amount of pressure in the priming chamber can control a higher inlet pressure. When the pressure in the priming chamber is released, the inlet pressure and spring forces the rolling diaphragm and piston assembly to move, allowing the inlet pressure to run through the angle outlet.

### C. Maintenance

Where difficulty in performance is experienced, the valve manufacturer or his authorized representative shall be contacted if any field adjustment is to be made.





## TECHNICAL DATA

## DELUGE SPRINKLER SYSTEM

The Viking Corporation, 210 N Industrial Park Drive, Hastings MI 49058

Telephone: 269-945-9501 Technical Services 877-384-5464 Fax: 269-818-1680 Email: techsvcs@vikingcorp.com

The Viking pneumatic actuator must be kept free of foreign matter and freezing conditions that could impair its operation. At regular intervals, at least annually, inspect and test the pneumatic actuator. The frequency of the inspections is dependent upon the condition of the water and release system.

NOTE: PRIOR TO PERFORMING ANY WORK ON THE PNEUMATIC ACTUATOR, REFER TO SYSTEM DESCRIPTION FOR INSTRUCTIONS AND WARNINGS REGARDING THE FIRE PROTECTION SYSTEM AND RELEASE SYSTEM.

### D. Inspection

1. Place the fire protection system out of service.
2. Trip the release system.
3. Drain any accumulated condensation from the release system.
4. Purge the release system of any foreign matter.
5. Place the release system back in service.
6. Establish pressure on the pneumatic actuator inlet.
7. Trip test the pneumatic actuator by activating a pneumatic release. The pneumatic actuator should release the inlet pressure through the outlet.
8. Reset the release system, then reset the fire protection system and secure all main control valves open.
9. Should the pneumatic release fail to trip or reset, remove it from service and disassemble. Clean and/or replace any dirty or worn parts and then reinstall it. Repeat the inspection procedures.

### E. Disassembly (Figures 45-46)

1. Place the fire protection system out of service.
2. Trip the release system.
3. Remove the pneumatic actuator
4. Remove the three cover screws.

CAUTION: The assembly is under spring tension.

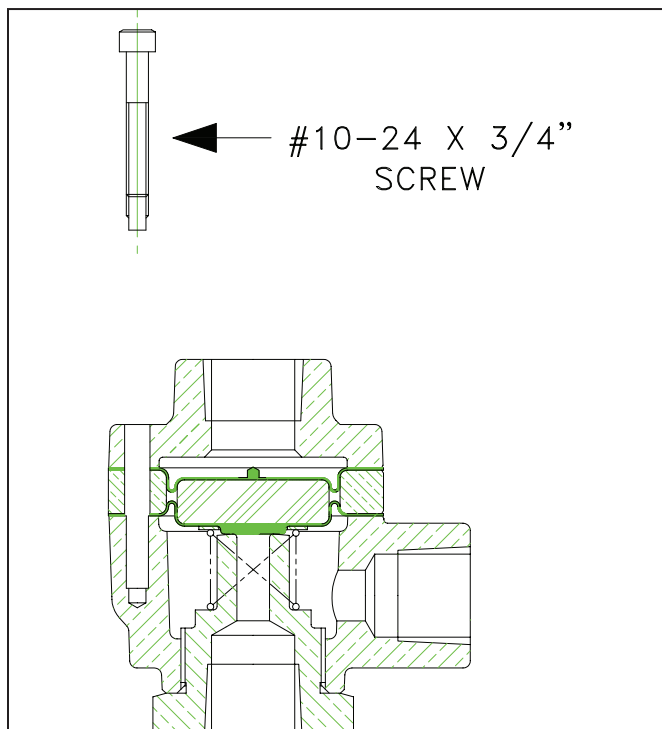


Figure 45

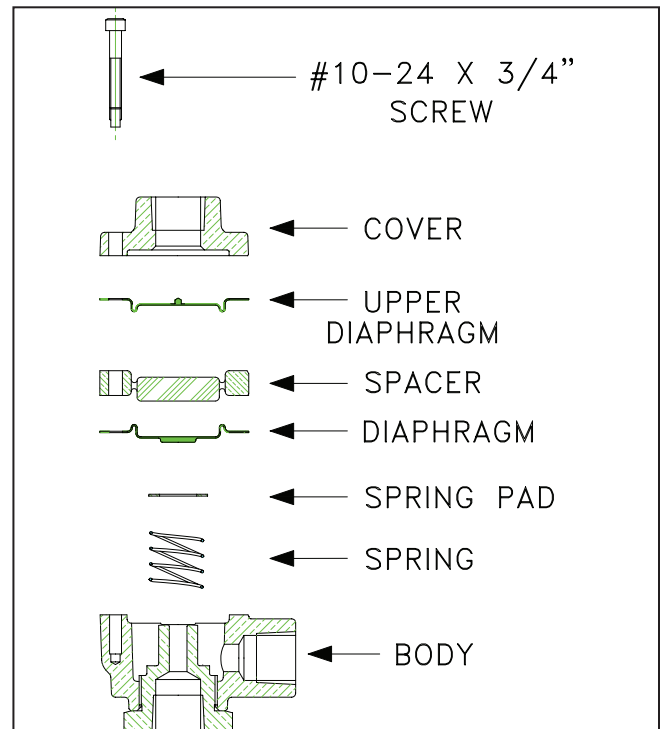


Figure 46



## TECHNICAL DATA

## DELUGE SPRINKLER SYSTEM

The Viking Corporation, 210 N Industrial Park Drive, Hastings MI 49058

Telephone: 269-945-9501 Technical Services 877-384-5464 Fax: 269-818-1680 Email: techsvcs@vikingcorp.com

5. Separate the cover from the lower assembly.
6. Separate the upper diaphragm, piston, lower diaphragm, spring pad from the body.
7. Clean and/or replace dirty or worn parts.
8. If required, remove the valve seat from the body and replace (Figure 47).

### F. Reassembly

1. Reverse the Disassembly procedure, making sure that the burr side of the spring pad is toward the spring, away from the lower diaphragm.
2. Purge all trim piping of foreign matter.
3. Reinstall the pneumatic actuator and trim piping.
4. Repeat inspection procedures.
5. Check and repair all leaks.
6. Reset the release system, then reset the fire protection system and secure all main control valves open.

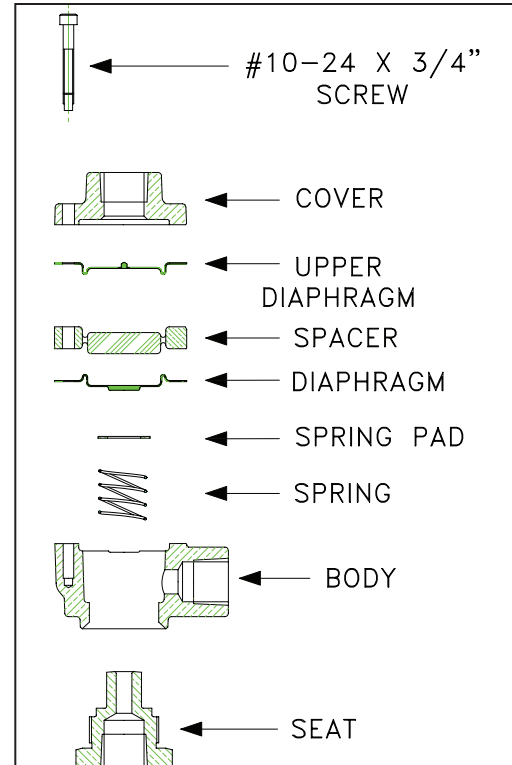


Figure 47

## IX. PRESSURE OPERATED RELIEF VALVE (PORV)

### A. Description

Viking Model C-1, D-1, and D-2 Pressure Operated Relief Valves (PORV) are used in Viking deluge systems when automatically resetting releases are used. Once tripped, the PORV maintains a positive vent to prevent the deluge valve from automatically resetting prematurely. The device is automatically reset when the pressure is removed from the control diaphragm. The Model C-1 is designed to trip when approximately 5 PSI (.3 bar) of pressure is applied to the control diaphragm. The trip point is non-adjustable. The Model D-1 and Model D-2 are designed to trip when the 10:1 ratio between the inlet and trip port is overcome. The 10:1 ratio can be obtained when the trip port is pressurized with water from the intermediate chamber of the control valve, or when the water in the inlet is drained from the prime chamber of the control valve. The Model D-2 PORV is similar to the Model D-1, except some components are specially plated for additional corrosion resistance.

The Model C-1 PORV may also be used to trip the deluge valve by applying air or water pressure to the PORV control diaphragm. The PORV is shipped with Viking conventional deluge valve trim.

### B. Operation

The PORV maintains a positive vent on the priming chamber to prevent the deluge valve from automatically resetting. It keeps the valve open if the detection system fails and resets. The inlet side of the PORV is connected directly to the top chamber of the deluge valve. In the set position, pressure is supplied through the orifice to both sides of the clapper diaphragm, which is held closed because of the area differential. When the deluge valve is tripped, pressurized water normally trapped above the clapper diaphragm is allowed to escape. If a release resets, the deluge valve will continue to operate until manually reset.

### C. Inspections, Tests, and Maintenance

The PORV should be tested for operation annually. Where difficulty in performance is experienced, the valve manufacturer or his authorized representative shall be contacted if any field adjustment is to be made.



## TECHNICAL DATA

## DELUGE SPRINKLER SYSTEM

The Viking Corporation, 210 N Industrial Park Drive, Hastings MI 49058

Telephone: 269-945-9501 Technical Services 877-384-5464 Fax: 269-818-1680 Email: techsvcs@vikingcorp.com

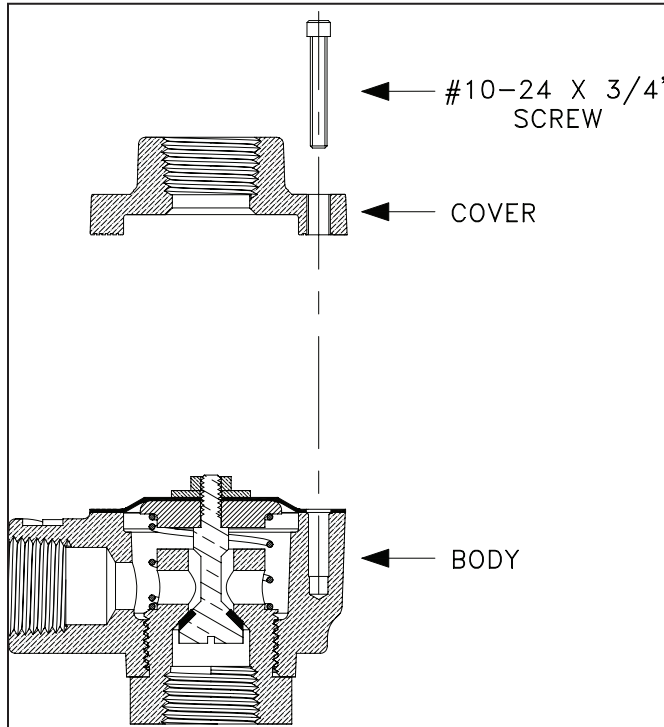


Figure 48

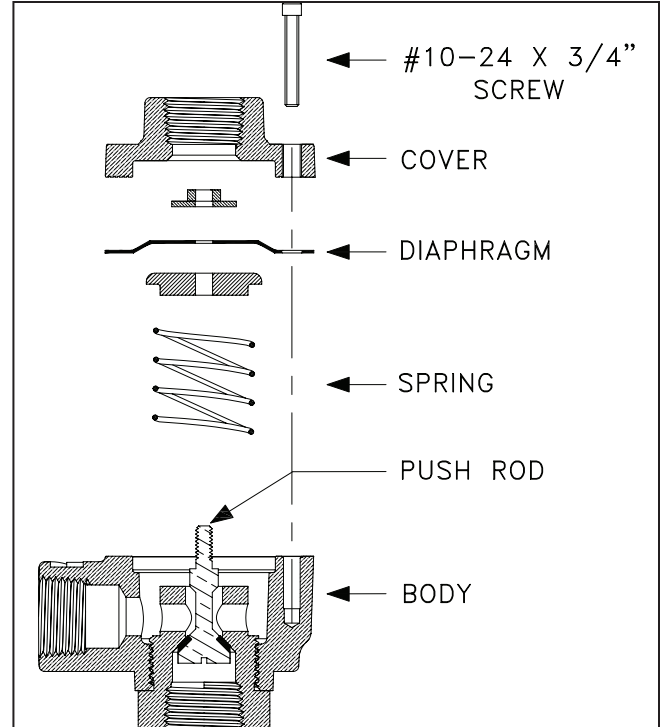


Figure 49

### Testing

For the Model C-1 PORV, trip the deluge system at 5 to 7 PSI (.3 to .5 bar) system pressure. Water should flow from the 1/4" (8 mm) drain port located in the middle of the PORV. When water flows from the 1/4" (8 mm) drain port, the PORV should trip and discharge water from the 1/2" (15 mm) drain outlet. For the Model D-1 and D-2 PORV, trip the deluge system at 10:1 system pressure. The PORV should operate, and water will flow from the outlet.

### Disassembly (Figures 48-49)

1. Place the deluge system and the release system out of service.
2. Remove the PORV from the deluge valve trim.
3. For the Model C-1 PORV, unscrew and separate body assembly from end cover assembly. The spring will fall free. For the Model D-1 or D-2 PORV, remove the cover screws, and separate the cover from the body.
4. For the Model C-1, remove screws to replace diaphragm assembly. The metal plate of the diaphragm must face the spring and schrader valve core. For the Model D-1 or D-2, hold the push rod with a screw driver, and remove the jam nut. Remove the washer, diaphragm and support. The push rod will come out.

### Reassembly

1. For the Model D-1 or D-2 PORV, install the push rod, support, and diaphragm. Place the washer over the push rod and install the nut. Use caution to not damage the diaphragm when tightening the jam nut.
2. For the Model D-1 or D-2, rotate the assembly to align the holes in the diaphragm with the holes in the body. Install and tighten the cover screws.
3. To replace the schrader valve core in the Model C-1, the special tool (Viking Part No. 01715A) will be required.
4. Test operation of device after reassembly. See Annual Test procedure.



## TECHNICAL DATA

DELUGE SPRINKLER  
SYSTEM

The Viking Corporation, 210 N Industrial Park Drive, Hastings MI 49058

Telephone: 269-945-9501 Technical Services 877-384-5464 Fax: 269-818-1680 Email: techsvcs@vikingcorp.com

## X. SOLENOID VALVE

### A. Description

The solenoid valve is a two-way type with one inlet and one outlet. It is a packless, internal pilot operated valve, suitable for use in releasing water pressure from the priming chamber of Viking Model E Series Deluge Valves and Viking Model H Series Flow Control Valves. The solenoid valve has floating diaphragm construction, which requires a minimum pressure drop across the valve to operate properly. The valves are available with a voltage rating of 24V DC in a normally closed or normally open configuration, or 110/50-120/60 normally closed configuration. These solenoid valves are for use with system control units that are listed and/or approved for releasing service for water based fire protection systems.

### B. Operation

The solenoid valve is an internal pilot operated valve with pilot and bleed orifices utilizing line pressure for operation. Normally closed, de-energized valves open when energized. Power is applied to the solenoid coil, causing the solenoid core to lift, opening the pilot orifice to the outlet side of the valve. This relieves pressure on the top side of the diaphragm and allows the line pressure to open the valve. When de-energized, the solenoid core reseals the pilot orifice, allowing the line pressure to build above the diaphragm, closing the valve.

Normally closed solenoid valves are commonly used as releases for Viking deluge and flow control valves. Opening the solenoid valve allows the deluge or flow control valve to open.

**NOTE:** When using a normally closed solenoid valve as a release, a system will not operate automatically on total loss of power. For this reason, it is recommended and normally required that an emergency back-up, supervised power supply be provided to maintain fire protection during interruptions of the main power system and to meet the requirements of appropriate Authorities Having Jurisdiction.

### C. Inspections, Tests, and Maintenance

**WARNING:** Prior to operating the solenoid valve, be sure to close the system control valve to avoid unintentional operation of the deluge valve.

1. The valve must be operated at least monthly. The valve must open and close freely. When open, the water flow must be clear and clean at the proper flow rate. When closed, a total water shut-off must be observed. After the test, the strainer must be cleaned. Prior to cleaning the strainer, the priming line valve must be closed and the priming line depressurized. After the strainer is cleaned, the priming line valve must be reopened.
2. The valve must be inspected at least monthly for cracks, corrosion, leakage, etc., and cleaned, repaired, or replaced as necessary.
3. At least annually, the valve diaphragms and seats must be inspected and if necessary, repaired or replaced.

**WARNING: CLOSE SYSTEM CONTROL VALVE, TURN OFF POWER SUPPLY, AND DEPRESSURIZE VALVE BEFORE DISASSEMBLING VALVE. IT IS NOT NECESSARY TO REMOVE THE VALVE FROM THE PIPE LINE TO MAKE INSPECTIONS.**

4. When lubricating valve components, use a high grade silicone grease (Dow Corning® 111 Compound Lubricant or equal).
5. When reassembling, tighten parts to torque values indicated in Parker's maintenance instructions (packed with valve).
6. After maintenance is completed, operate the valve a few times to be sure of proper operation. A metallic "click" signifies the solenoid is operating.
7. It is recommended that the valve be replaced at seven-year intervals. Shorter intervals may be required if the valve is subject to corrosive water supplies or atmospheres.

**TECHNICAL DATA****DELUGE SPRINKLER  
SYSTEM**

The Viking Corporation, 210 N Industrial Park Drive, Hastings MI 49058

Telephone: 269-945-9501 Technical Services 877-384-5464 Fax: 269-818-1680 Email: techsvcs@vikingcorp.com

8. All service must be performed by qualified personnel. Upon completion of inspections or replacement of the valve, the entire system must be checked for proper operation. See appropriate system description and testing instructions for additional information.

## **XI. EMERGENCY RELEASE**

### **A. Description**

The Viking Emergency Release operates as a manual tripping device for use on deluge valve trim and on hydraulic and pneumatic release systems controlling operation of Viking deluge and flow control Valves. It consists of a special quick-opening, lever operated ball valve mounted in a stainless steel enclosure with a full opening door.

### **B. Operation**

The special quick-opening, lever operated ball valve of the emergency release is installed on a special ½" (15 mm) NPT nipple inside a stainless steel enclosure. The valve is closed when the handle is aligned with the pipe nipple. This allows the valve to be closed during normal operation when the door of the emergency release is closed.

The following operation instructions are printed on the outside of the emergency release door:

"IN CASE OF FIRE, OPEN DOOR AND PULL LEVER"

When the door of the emergency release is opened and the handle of the special ball valve is pulled, the valve opens to relieve pressure maintained on the release system.

#### Hydraulic Release Systems

Hydraulic release systems control operation of Viking deluge and flow control valves by maintaining water pressure in the priming chamber of the valve used. Opening of the emergency release allows water from the hydraulic release system to flow to open drain, relieving water pressure from the priming chamber to allow the valve to open.

#### Electric Release System

Standard trim for deluge and flow control valves equipped for electric release, requires an emergency release to be connected to the hydraulic release trim between the priming chamber of the valve used and the electric solenoid. The emergency release allows operation of the system independent of the electric release system.

#### Pneumatic Release System

Pneumatic release systems control operation of deluge and flow control valves by maintaining pneumatic pressure on a pneumatic actuator installed in the release trim of the valve used. Opening of the emergency release allows pressure from the pneumatic release system to flow to atmosphere, allowing the pneumatic actuator to open. Opening of the pneumatic actuator allows water from the deluge or flow control valve priming chamber to flow to open drain, and the valve to open.

#### After Operation

After system has been reset, return the handle to its normal operating position and close the door.

### **C. Maintenance**

The Viking emergency release must be kept free of foreign matter, freezing conditions, corrosive atmospheres, contaminated water supplies, and any condition that could impair its operation or damage the device.

**TECHNICAL DATA****DELUGE SPRINKLER  
SYSTEM**

The Viking Corporation, 210 N Industrial Park Drive, Hastings MI 49058

Telephone: 269-945-9501 Technical Services 877-384-5464 Fax: 269-818-1680 Email: techsvcs@vikingcorp.com

**D. Inspection**

1. Verify that the door of the emergency release is not obstructed and opens freely.
2. Check for signs of mechanical damage and/or corrosive activity. If detected, perform maintenance as required or, if necessary, replace the device.

**E. Testing (Refer to technical data for the valve used.)**

1. Notify the Authority Having Jurisdiction and those in the area affected by the test.
2. Close the main water supply control valve, placing the system out of service.
3. Open the door of the emergency release and pull the handle. Air or water from the release system should discharge to open drain.
4. When testing is complete, return the handle to its normal operating position and close the door.
5. Establish normal operating pressure in the release system.
6. Refer to technical data for the valve used to open the main water supply control valve and place the system back in service.
7. Notify the Authority Having Jurisdiction and those in the area affected by the test that the system is back in service.

**XII. RELEASE CONTROL PANEL****A. Description**

The Viking VFR400 is a microprocessor based multi-hazard releasing control panel for use on deluge sprinkler systems. The Model VFR400 is Underwriters Laboratory listed, FM Global approved and complies with UL Standard 864, Ninth Edition, for Local Control Units for Releasing Service. It is designed to be compatible and installed in accordance with the requirements of NFPA 13, NFPA 15, NFPA 16 and NFPA 72.

The VFR400 is housed in a steel cabinet with removable door and key lock. Standard is red with black and white trim. The panel is available for use with either 120 VAC or 220 VAC for primary power. The cabinet will house up to two (2) 18AH standby batteries which are capable of powering the unit in excess of 90 hours in the event of an AC power failure. The VFR400 release control panel can be used with a wide range of compatible initiating devices, such as spot heat detectors, smoke detectors and linear heat detectors (10,000 ft. - SAFE-FIRE) or (3,500 ft. - Protectowire).

**B. Operation**

Refer to system data for operational information and proper wiring diagram and required program.

**C. Inspections, Tests, and Maintenance**

The Viking VFR400 release control panel must be kept free of foreign matter and environmental conditions that could impair its operation.

Refer to VFR400 Installation and Operation Manual for appropriate testing procedures.

For minimum maintenance and inspection requirements, refer to NFPA 72 and NFPA 25. In addition the Authority Having Jurisdiction may have additional maintenance, testing and inspection requirements that must be followed.

**XIII. RELEASE LINE AIR SUPPLY ASSEMBLY****A. Description**

The Viking Release Line Air Supply Assembly is a factory assembled unit consisting of galvanized pipe and fittings, a restricted orifice with a pressure gauge located on either side, and an air supervisory switch downstream of the orifice. The restricted orifice limits flow into the release system. This

**TECHNICAL DATA****DELUGE SPRINKLER  
SYSTEM**

The Viking Corporation, 210 N Industrial Park Drive, Hastings MI 49058

Telephone: 269-945-9501 Technical Services 877-384-5464 Fax: 269-818-1680 Email: techsvcs@vikingcorp.com

prevents system pressure from being replaced faster than it can escape from an open detector after it operates. The pressure gauges indicate supply pressure and system pressure. The supervisory switch monitors the system pressure. When properly wired and energized, a drop in system pressure will cause the switch to send the electrical signal necessary to operate an alarm indicating a critically low pressure condition in the release system.

The Viking Explosion-Proof/Watertight Release Line Air Supply Assembly is for use in areas exposed to weather or explosive atmospheres. The unit features an explosion-proof/watertight air supervisory switch downstream of the orifice.

## **B. Operation**

The release line air supply assembly limits the rate at which air or nitrogen can enter the release system. One gauge indicates the supply pressure entering the restricted orifice; the other indicates the pressure in the release system piping. When the supervisory switch is properly wired for normally closed operation, a drop in pressure in the release system piping (below the setting of the supervisory switch) will cause the electrical contacts to change position, sending an electrical signal to sound an alarm (if provided). This indicates a critically low pressure condition in the release system.

## **C. Maintenance**

### Weekly Maintenance

1. Check air-pressure gauge readings. Both gauges should read the same pressure. If they differ, perform annual inspection.

### Annual Inspection

1. Establish a fire patrol in area.
2. Close the main control valve, placing the system out of service.
3. Shut off the air or nitrogen supply to the release line air supply assembly.
4. Trip the release system to relieve pressure in the release line air supply assembly. Note the point at which a signal appears. [Factory setting: approximately 25 PSI (207 kPa)].
5. Separate the restricted orifice union assembly and remove the screened orifice restriction.
6. If necessary, clean the restricted orifice by flushing in soap and water. Rinse and dry the restricted orifice assembly completely.
7. Re-install restricted orifice assembly.
8. Reset the pneumatic release system, pressurizing the release line air supply assembly. When air pressure stops flowing, pressure gauges should read the same. The low air pressure alarm signal should end when the system pressure reaches the set point of supervisory switch.
9. Open main control valve. Place system in service. Follow procedures in the technical data for system used.

### Pressure Switch Adjustment

Consult the appropriate technical data for recommended pressure for the system used. Viking supervisory switches are factory set. If adjustment is necessary, proceed according to the instructions given below.

#### *For the Model A-1 Assembly:*

1. Loosen the tamper-resistant lock screw, with the wrench supplied, and remove the switch cover. Use care not to lose the rubber O-ring screw retainers.
2. To adjust the set point, turn the adjustment knob(s) clockwise to raise the actuation setting, or counterclockwise to lower the actuation setting.
3. Verify pressure settings of the switch. To test for proper settings without energizing the circuit, connect an ohm meter to the circuit used. Alternately, raise and lower system pressure to verify proper operation of the switch. If further adjustment is necessary, repeat steps 2 and 3.



## TECHNICAL DATA

## DELUGE SPRINKLER SYSTEM

The Viking Corporation, 210 N Industrial Park Drive, Hastings MI 49058

Telephone: 269-945-9501 Technical Services 877-384-5464 Fax: 269-818-1680 Email: techsvcs@vikingcorp.com

4. Replace cover and tighten the tamper-resistant screws.
5. Energize the circuits.
6. Test for proper operation of the device.
7. Reset all necessary equipment and place the system in service. Refer to the appropriate technical data for the system used.

### *For the Explosion-Proof/Watertight Assembly:*

The Explosion-Proof/Watertight Air Supervisory Switch unit has two switches (one actuates at a 10 PSI decrease from normal, while the other actuates at a 10 PSI increase from normal). The operating point of the switches can be adjusted to any point between 10 and 175 PSI. The unit is factory set for the low-pressure switch to actuate when pressure decreases to 30 PSI (205 kPa). The two switches operate completely independently of one another, and each switch may be adjusted to actuate at any point the system requires. If adjustment of the air supervisory switch operating point is necessary:

1. **WARNING:** De-energize electrical circuitry to reduce the risk of ignition of hazardous atmospheres before opening the switch cover.
2. Loosen the tamper-resistant fasteners from the switch cover with the two cover access keys supplied and remove the switch cover.
3. Remove the screw from cover sleeve and raise the cover sleeve for access to the pressure adjustment knobs.
4. To adjust the low-pressure trip point, turn the low-pressure adjustment knob clockwise to raise the actuation pressure setting, or counter-clockwise to lower the actuation point. Final adjustment should be made with a pressure gauge.
5. Replace the cover sleeve and the screw.
6. Replace the switch cover and tamper-resistant fasteners. Cover screws must be torqued to a minimum of 20 in. lbs.

## XIV. AIR SUPPLIES FOR RELEASE SYSTEMS

### A. Description

Pneumatic deluge release systems require a compressed air or gas supply. The pneumatic system supporting the deluge pneumatic release system must be maintained dry and free of condensation. Moisture in the pneumatic system may cause ice to form in the releases or release piping when exposed to freezing temperatures. Moisture will also increase the deterioration of the galvanized piping normally used in the release system.

Note: If a common air/gas supply is used for multiple release systems, a separate air maintenance device and an air pressure gauge are required for each release system. This will allow release system isolation for maintenance and individual operation.

The time necessary to pressurize 1,000 ft (304.8 m) of release line to 10 PSI (0.689 bars), minimum operating pressure, with 20 PSI (1.38 bars) of supply pressure and the appropriate orifice is approximately as follows:

<u>Minutes</u>	<u>Pipe Size</u>	<u>Orifice Size</u>
3	½" (15 mm)	1/32" (0.79 mm)

The deluge valve control equipment will open the deluge valve when release-line pressure is reduced to the trip point. In practice, 30 PSI (2.07 bars) air pressure is used when water pressures are 175 PSI or less and 50 PSI (3.45 bars) air pressure is used when water pressures are above 175 PSI and is commonly used with a low air-pressure alarm at 15 PSI (1.03 bars). Lower pressures should not be used unless necessary for higher speed.

An air maintenance device is required when the pneumatic release line is supplied by an air compressor. The air maintenance device will automatically maintain the required air pressure on the system.



**TECHNICAL DATA****DELUGE SPRINKLER  
SYSTEM**

The Viking Corporation, 210 N Industrial Park Drive, Hastings MI 49058

Telephone: 269-945-9501 Technical Services 877-384-5464 Fax: 269-818-1680 Email: techsvcs@vikingcorp.com

For details on each device making up the air supply system, see the Deluge System - Equipment section of the *Viking Engineering and Design Data Book*.

**B. Viking Model C-1 Thermostatic Release Systems with a Bottled Gas Supply**

Special attention must be given to release systems employing a bottled-gas supply. Because only a limited amount of gas is available, small leaks which normally would go unnoticed in systems being supplied by mechanical compressors, can become critical to the system's overall performance. If the system is to function at temperatures as low as -40° F. (-40° C.), and if bottled nitrogen is the gas supply for the release system, the system is particularly susceptible to leakage, and special care should be taken to ensure against leaks throughout the entire system.

Some techniques which can be employed to ensure against system leakage are:

1. The use of cast iron fittings since their use results in fewer leaks than the use of malleable fittings.
2. Internally clean all piping in the supply and release systems prior to assembly since dirt and small chips may lodge under the clapper of the releases and create small leaks. Particular care should be taken in the connection of the gas-supply tank to the system. During system assembly, all threads should be inspected for imperfections.
3. When the system is assembled, test for leaks by hydrostatically testing 200 PSI (13.79 bars) for 2 hours and pneumatically test release line at 40 PSI (2.76 bar) for 24 hours. Normal operating pressure of the system should be set at 30 or 50 PSI (2.07 bars to 3.45 bars). If there is leakage, subject the entire system to a soap-bubble test in an effort to locate the leaks. Repair any leaks. Leaks in the release system do not impair in any way the system's ability to react to a fire condition, however, they will consume excessive quantities of gas and make necessary frequent cylinder replacement. Failure to detect leaks in time will result in low release system pressure and the possible tripping of the system. A low air pressure alarm switch must be installed on the release line as a supervisory alarm.

**XV. DEHYDRATOR****A. Description**

The Dehydrator is a manually regenerated desiccant-type air dryer. The desiccant acts as a moisture indicator by changing color, and is visible through the required bowl guard and transparent plastic bowl. The unit is to be used on compressed air service only. The unit should be located on the service side of the air compressor, as close as possible to the system, and ahead of any other system devices.

**B. Operation**

The dehydrator directs the incoming air from the bottom to the top of the polycarbonate plastic bowl. The silica gel absorbs the moisture without physically changing. As the relative humidity increases, the silica gel begins to change color from dark blue to light pink, indicating the desiccant must be replaced.

Note: When the original desiccant is replaced with part number 02535A, the color will be orange, and will turn clear when it has become saturated.

**C. Maintenance**

The dehydrator must be regularly inspected to ensure the drying capability of the desiccant. Replace the desiccant when the color has changed from dark blue to light pink. Notice: When the original desiccant is replaced with part number 02535A, the color will be orange, and will turn clear when it has become saturated. In addition, the recommended condensate trap should be drained on a regular basis. The frequency of the required maintenance is dependent upon the relative humidity and volume of air to be dried. Regular maintenance of the air supply equipment, such as draining condensation from the air compressor receiver, will increase the life of the desiccant.



## TECHNICAL DATA

## DELUGE SPRINKLER SYSTEM

The Viking Corporation, 210 N Industrial Park Drive, Hastings MI 49058

Telephone: 269-945-9501 Technical Services 877-384-5464 Fax: 269-818-1680 Email: techsvcs@vikingcorp.com

**WARNING:** Prior to performing any maintenance on a compressed air system, isolate the equipment and relieve all trapped pressure. Failure to do so may result in injury and/or accidentally tripping the fire protection system.

### D. Disassembly

1. Do not allow the fire protection system air pressure to drop below the minimum system service pressure.
2. Close the control valve on the system side of the dehydrator.
3. Close the air supply control valve to the dehydrator.
4. Open the drain valve on the condensate drip leg to relieve the trapped pressure from the dehydrator. Drain pressure from the dehydrator. Drain all condensate, and then close the valve.
5. Press in the retainer latch on the dehydrator clamp ring. Turn the clamp ring left while holding the bowl guard, and exert a downward pull until the clamp ring, the bowl guard, and the bowl drop free.
6. Pour out used desiccant.
7. The polycarbonate plastic bowl can be adversely affected by certain compressor oils, chemicals, household cleansers, solvent, paint, or fumes. Inspect the bowl and immediately replace if crazed, cracked, damaged, or deteriorated. When the bowl becomes dirty, wipe with a clean, dry cloth.
8. If further disassembly is required, refer to assembly drawing.

### E. Reassembly

1. Open desiccant bag and fill bowl. Shake or tap to settle the desiccant. Add or remove sufficient quantity of desiccant to make level 1/8" (3.175 mm) below the inner step of the bowl.
2. Reinstall bowl, bowl guard, and clamp ring. Turn clamp ring to the right until the latch locks.
3. Open the main air supply valve to pressurize the dehydrator. Check for leaks.
4. Open the control valve on the system side of the dehydrator. Check for leaks.

## XVI. WATER-SPRAY FIXED SYSTEMS

A *water spray system* is an automatic or manually actuated fixed pipe system permanently connected to a water supply. The system is equipped with water spray nozzles designed to provide a specific water discharge and distribution over the protected surfaces or area. Water spray systems are designed to provide water delivery to numerous specialized hazards and equipment for fire control, extinguishment, prevention, and/or exposure protection. Water spray systems are installed in accordance with the requirements in NFPA 15, *Standard for Water Spray Fixed Systems for Fire Protection*. Note: For additional information on Water Spray Design, refer to Viking technical data page 208 a-s.

Information in this section does not apply to water spray protection from portable nozzles, sprinkler systems, monitor nozzles, water mist suppression systems, explosion suppression, or other means of application covered by other NFPA standards.

### A. System Applications

Water spray systems are usually used in applications where the fire protection requirements are beyond the capability of a standard sprinkler system. Water spray systems are permitted to be installed independently of, or supplementary to, other forms of fire protection systems or equipment. They are frequently used in combination with sprinkler systems, with the sprinkler system portion designed and installed in accordance with NFPA 13, *Standard for Installation of Sprinkler Systems*.

Water spray applications include protection of the following hazards:

- Storage tanks of flammable liquids and gases
- Ordinary Class A combustibles such as wood, paper, and textiles
- Electrical hazards such as transformers, oil switches, motors, and cable trays



## TECHNICAL DATA

DELUGE SPRINKLER  
SYSTEM

The Viking Corporation, 210 N Industrial Park Drive, Hastings MI 49058  
Telephone: 269-945-9501 Technical Services 877-384-5464 Fax: 269-818-1680 Email: techsvcs@vikingcorp.com

## B. General Requirements

The design of water spray systems can vary significantly, depending on the nature of the hazard and the protection objectives. A determination of the physical and chemical properties of the materials to be protected by the water spray system must be considered. The flash point, specific gravity, viscosity, miscibility, temperature of the water spray, and the normal temperature of the hazard to be protected are also factors that must be considered.

Water spray systems must be designed to accomplish one or more of the following (refer to sections E-M for applications in which these objectives are discussed). Also refer to sections 7.2-7.5 in NFPA 15-2007 Edition.

- *Extinguishment* of fire by waterspray is accomplished by cooling, smothering from produced steam, emulsification of some liquids, dilution in some cases, or a combination of these.
- *Control* of burning is accomplished by an application of water spray to the burning materials, producing controlled burning. Fire control can be applied where combustible materials are not susceptible to complete extinguishment by water spray is not possible or preferable.
- *Exposure protection* uses water spray application directly to the exposed structures or equipment to remove or reduce heat transfer. Note: Using water spray curtains and subdividing fire areas can provide some protection against fire exposure under favorable conditions. Unfavorable conditions would include wind, thermal updrafts, and inadequate drainage.
- In *prevention* of fire, water spray is used to dissolve, dilute, disperse, or cool flammable materials or to reduce flammable vapor concentrations below the lower flammable limit (LFL).

Methods of fire extinguishment/control are explained as follows:

*Surface cooling* uses complete water spray coverage to cool surfaces. This method is effective with combustible liquids having a flash point greater than 140 °F (60 °C). Surface cooling removes the potential source of ignition or cools the surface to a temperature where the propagation of flame cannot be sustained.

*Coating* occurs when water spray application provides a thin coating of water on vertical and horizontal surfaces of the protected equipment during system activation. A continuous film of water forms over the surface of materials that are not water miscible.

In *emulsification*, water spray is applied over the entire area of flammable liquids. This method is used for liquids not miscible with water.

*Dilution* is used where the combustible liquid (such as alcohol) is water soluble (miscible) and allows the water application to mix with and dilute the combustible liquid. Dilution renders the liquid non-flammable.

*Steam smothering* is the process in which a fire turns water droplets into steam and then during vaporization, the steam absorbs heat from the fire to create a smothering effect. This method may be used where the intensity of the expected fire would generate adequate steam from the water spray, which is applied to essentially all the areas of expected fire.

With *redirection*, water under pressure sweeps standing oil from the surfaces of the equipment being protected, to less hazardous areas, such as a predesigned drainage pit.

With *vapor exhaust*, if the equipment (such as a transformer) is indoors or in an enclosed vault, a ventilation system may be required to reduce vapor concentrations to a point 25% below the lower flammable limit of the vapor. In locations where the equipment is exposed to the elements, vapors are removed by the wind.

Note: Where water spray can encounter confined materials at a high temperature or with a wide dilution range, the slopover or frothing hazard shall be evaluated.

Water soluble materials are required to be tested under conditions of use (if data is not already available) to determine the applicability of water spray design for extinguishment by control, by dilution, or with an adequate application rate and coverage.

**TECHNICAL DATA****DELUGE SPRINKLER  
SYSTEM**

The Viking Corporation, 210 N Industrial Park Drive, Hastings MI 49058

Telephone: 269-945-9501 Technical Services 877-384-5464 Fax: 269-818-1680 Email: techsvcs@vikingcorp.com

Water spray systems are not permitted for direct application of water on materials that react violently or increase hazardous products as a result of heated vapor emission, or for applications involving liquefied gases at cryogenic temperatures (such as natural gas), which boil violently when heated by water.

Equipment to be protected must be evaluated to determine whether water spray application could cause damage, distortion, or failure when operating at high temperatures.

#### Water Discharge Control or Containment Systems

Section 4.4 of NFPA 15 contains requirements for control or containment systems. The rapid removal of spills and runoff from water spray systems greatly reduces the amount of fuel involved and prevents the spread of fire into adjacent areas. The following methods are acceptable:

- Curbing and grading prevents water or burning liquid from spreading horizontally. Grading with concrete or other hard surfacing is used to slope toward drains, trenches, ditches, or other safe area.
- Underground or enclosed drain systems to capture leaks spills as well as normal drainage are normally used in process areas and buildings handling hazardous chemicals. There should be a sufficient number of drains to capture runoff without pooling.
- Open trenches or ditches may be considered, however, they should not be routed through another fire area, or fire stops should be provided. Note: underground or enclosed drains are preferred, to avoid exposing equipment to burning liquids.
- Diking or impoundment around a flammable liquid storage tank contains the spilled liquid and drains may be installed in the diked area. Refer to NFPA 30, *Flammable and Combustible Liquids Code*, for diking requirements for the tank storage of flammable and combustible liquids.

Each of the methods has advantages and disadvantages. In most cases a combination of methods should be used. The system must accommodate the total combined flow for the fire's expected duration, with the exception that the duration may be reduced where approved.

## **C. System Components**

All components must be coordinated to provide complete systems and the components that affect system operation must be listed and rated for the maximum working pressure to which they are exposed, and not less than 175 PSI (12.1 bar).

### **1. Water Spray Nozzles**

Water spray nozzles are intended to protect a hazard that cannot be adequately protected by conventional sprinkler systems alone and must be listed for use in water spray systems. Unlike sprinklers, water spray nozzles project a water spray in a specific direction and pattern. The effectiveness of water-spray protection depends on many factors such as nozzle spacing, elevation, direction or angle to discharge, water pressure, wind velocity and the flashpoint, viscosity and temperature of the flammable liquid to be protected.

#### Spray Nozzle Positioning

Spray nozzles are permitted to be placed in any position, within their listing limitations, necessary to obtain proper coverage of the protected area. The following factors must be evaluated:

- The shape and size of the area to be protected
- The nozzle design and characteristics of the water spray pattern to be produced
- The effect of wind and fire draft on very small drop sizes or on large drop sizes with little initial velocity
- The potential to miss the target surface and increase water wastage
- The effects of nozzle orientation on coverage characteristics
- The potential for mechanical damage



## TECHNICAL DATA

DELUGE SPRINKLER  
SYSTEM

The Viking Corporation, 210 N Industrial Park Drive, Hastings MI 49058  
Telephone: 269-945-9501 Technical Services 877-384-5464 Fax: 269-818-1680 Email: techsvcs@vikingcorp.com

The design must ensure that the nozzle spray patterns meet or overlap. Maximum nozzle spacing (vertically or horizontally) is 10 ft (3 m), except where specifically listed.

Refer to technical data page 208 a-s, NFPA 15, and the appropriate technical data page for the nozzle being used, for additional nozzle positioning guidelines. Also refer to the following sections in this document for the particular hazard being protected for specific nozzle spacing guidelines.

#### Types of Spray Nozzles

Each nozzle is chosen for its specific discharge characteristics (capacity, spray range, spray angle, etc.) Open nozzles (no operating element) are most often selected, however, automatic nozzles are permitted where positioned and located so as to provide satisfactory activation time and distribution. Water spray systems typically require that the water be applied rapidly to all protected surfaces at the same time, which might not be possible with closed nozzles. Nozzle placement for adequate coverage is often in conflict with response time when automatic nozzles are used.

Certain cases where closed nozzles are used to limit the discharge of water to prevent equipment damage (turbine bearings, for example). Because automatic nozzles have operating elements similar to sprinklers, they also have the same requirements regarding supply of replacement nozzles, higher temperature rated nozzles must be used when located near heat sources, and protected with listed guards if subject to mechanical damage.

Medium- and high-velocity discharge water in a spray filled solid-cone pattern. For example, Viking's Model A-2, A-2X, B-2, C-2, D-2 Solid Cone Spray Nozzles (technical data page 20-32) are open, directional nozzles units with two-piece construction consisting of a cast bronze body and threaded insert. The insert determines the included angle of discharge and the body construction provides a uniform distribution throughout the discharge pattern. Optional dust plugs are available to prevent foreign material from entering the open end of the spray nozzle. They are designed to blow off when the system piping is pressurized.

Low-velocity nozzles usually deliver a finer spray in a spherical or solid cone shape. One example is Viking's Model M Nozzles (technical data page 31a-e), which are designed with a special ring for uniform distribution throughout the cone-shaped spray pattern. These frame style spray nozzles are available automatic or open and in various spray pattern discharge angles to meet design requirements. The deflector determines the included angle of spray pattern discharge. Other features include the small frame, which allows proper nozzle positioning even in congested areas, and the nominal 5 mm glass bulb contained entirely inside the frame for protection from most mechanical damage. The glass bulb operating elements are resistant to more corrosive atmospheres than metal elements. The special Teflon coating has been investigated for installation in corrosive atmospheres and is cULus listed as corrosion resistant.

To protect specific surfaces, special directional nozzles may be used. Viking Model E, 3D Spray Nozzles are open type spray nozzles designed for directional spray applications in fixed fire protection systems. They have an open design only with an external deflector that discharges a solid uniform cone spray of low- to medium- velocity water droplets. Model E Spray Nozzles are available in multiple orifice sizes and spray angles to meet design application requirements and they include a 1/2" NPT (DN15) external pipe thread. The spray angle is the included angle of discharge for each nozzle, and is also marked on the deflector. Figures in the technical data page (32a-j) illustrate the distribution width at various heights based on testing in the pendent position at 10, 20, and 60 PSI (0.7, 1.4, and 4.1 bar) discharge pressures. Note that at pressures above 60 PSI (4.1 bar), the spray pattern begins to decrease in width due to pull-in of the spray pattern. For exposure protection, see the figures in the technical data page for fixed position angle, distance for included angle spray pattern perpendicular to surface of object at the fixed angle of installation. Optional blow-off plugs are available for protection from dust and insect infestation and other accumulation of debris.

**TECHNICAL DATA****DELUGE SPRINKLER  
SYSTEM**

The Viking Corporation, 210 N Industrial Park Drive, Hastings MI 49058

Telephone: 269-945-9501 Technical Services 877-384-5464 Fax: 269-818-1680 Email: techsvcs@vikingcorp.com

**2. Valves**

System actuation valves and accessories used to operate the valve must be listed and compatible. Most water spray systems are required to operate automatically, and are also required to have a means of supplemental manual actuation that is independent of the automatic release system and detection devices.

System actuation valves are required to be as close to the hazard protected as possible, taking into account the following:

- Radiant heat from exposing fire
- Potential for explosions
- Location and arrangement of drainage facilities including dikes, trenches, and impounding basins
- Potential for freezing and mechanical damage
- Accessibility
- System discharge time

**3. Pipe and Fittings**

Pipe, tube, and fittings used in water spray systems must meet the requirements provided in sections 5.3 through 5.5 of NFPA 15. All piping and pipe supports used outdoors must be shop galvanized inside and out to protect against pipe corrosion and blockage of nozzles from loosened pipe corrosion. Malleable iron screwed fittings should be used on water spray systems to prevent damage resulting from the shock of the water hitting the empty fittings and the movement of the system upon system actuation.

All water spray system piping and fittings must be installed so that the system can be drained, with a means for verifying water flow through the drain. Each system is required to have drain connections sized in accordance with Table 6.3.3.7 in NFPA 15 for system risers, mains, and actuation valves. Auxiliary drains must be provided where a change in piping direction prevents drainage of system piping through either the main drain valve or open water spray nozzles.

**4. Corrosion Resistance**

Due to the typically harsh environment of water spray systems, system components installed outside, or in the presence of a corrosive atmosphere, must be corrosion resistant or suitably protected from corrosion.

**5. Protection Against Freezing, Earthquake Damage, and Areas of Explosion Potential**

Water-filled supply pipes, risers, system risers or feed mains pass through open areas, cold rooms, passageways, or other areas exposed to freezing must be protected with insulating coverings, frostproof casing, or other means capable of maintaining a temperature of at least 40 °F. A heated enclosure may be required. NFPA 13 requires valve rooms to be lighted and heated with a permanent heat source. Unheated areas may be protected with antifreeze systems in accordance with NFPA 13, if acceptable to the Authority Having Jurisdiction.

Sway braces or earthquake braces are recommended to minimize pipe movement and maintain pipe rigidity and integrity during discharge of the system. Upon system activation, the force of the water rushing into the pipe loop can cause significant pipe movement. Protection must be provided against earthquake damage, or damage from explosion, in areas where there is this potential, in accordance with NFPA 13.

**6. Hangers and Pipe Support**

The types of hangers used must be in accordance with NFPA 13. Hangers used outdoors or in locations where corrosive conditions exist are required to be galvanized, suitably coated, or fabricated from corrosion-resistant materials.

**TECHNICAL DATA****DELUGE SPRINKLER  
SYSTEM**

The Viking Corporation, 210 N Industrial Park Drive, Hastings MI 49058  
Telephone: 269-945-9501 Technical Services 877-384-5464 Fax: 269-818-1680 Email: techsvcs@vikingcorp.com

Water spray system piping must be supported in a manner equivalent to the performance requirements of NFPA 15 or NFPA 13 and the design certified by a registered professional engineer.

**7. Pressure Gauges**

Required pressure gauges must be listed and have a maximum limit at least twice the normal working pressure where installed. Pressure gauges must be located below the system actuation valve, above and below alarm check valves, and on the air or water supply to pilot lines. They must be removable, located where they won't be subjected to freezing, with at least one gauge at or near the highest or most remote nozzle on each separate section of the system, and at or near the nozzle calculated as having the least pressure under normal flow conditions.

**8. Alarms**

All automatic water spray systems must be provided with a local alarm so that any flow from a single automatic nozzle of the smallest orifice size installed on the system, or flow from any group of non-automatic nozzles will result in an audible alarm on the premises within 90 seconds after flow begins. Alarm requirements are found in section 5.11 of NFPA 15. Water flow alarms must be listed for this service and the unit is required to have a listed mechanical alarm or electric device. Outdoor water-motor alarm bells must be protected from the weather and be provided with guards.

An alarm test connection is required for all wet systems in accordance with NFPA 13.

**9. Strainers**

Main pipeline strainers are required for all systems with waterways less than 3/8" (9.5 mm) and for any system where the water is likely to contain obstructive material. These strainers must be accessible for flushing or cleaning. Pipeline strainers must be specifically listed for use in water supply connections and all strainers must be capable of removing all particles that could obstruct the spray nozzles (normally 1/8" (3.2 mm) perforations are adequate). Individual or integral strainers are required at each nozzle having a waterway smaller than 3/16" (5 mm).

**10. Supervision**

- Valves controlling the water supply to water spray systems are required to be supervised in the normally open position by one of the following:
- Central station, proprietary, or remote station alarm service
- Local alarm service that will cause the sounding of an audible signal at a constantly attended point
- Locking valves open
- Sealing of valves and approved weekly recorded inspection where valves are located within fenced enclosures under the control of the owner

**Arrangement and supervision of systems**

1. Electrical Systems: Water spray systems that depend on electric thermostats, relay circuits, flammable gas detectors, or other similar equipment must be arranged to be normally energized or completely supervised to provide positive notification in an abnormal condition in accordance with NFPA 72, unless failure of the detection system results in operation of the water spray system. Supervision includes (but is not limited to), the tripping device, solenoid valve, and any connecting wire.
2. Pneumatic and Hydraulic Systems must be supervised so that failure will result in positive notification of the abnormal condition, unless the failure results in operation of the water spray system.

**TECHNICAL DATA****DELUGE SPRINKLER  
SYSTEM**

The Viking Corporation, 210 N Industrial Park Drive, Hastings MI 49058

Telephone: 269-945-9501 Technical Services 877-384-5464 Fax: 269-818-1680 Email: techsvcs@vikingcorp.com

**11. Size of Systems, Water Supply, and Water Demand**

Water supplies must be designed to admit water into the piping and to discharge effective water spray from all open nozzles without delay. In most installations, effective water delivery from all open spray nozzles is within 30 seconds after detection.

A single system cannot protect more than one fire area. Furthermore, single systems should be designed to limit water flow rates, taking into consideration water supplies and the reliability of the protection. Large system size could decrease system reliability and increase transfer time, water wastage, and environmental impact. The number of systems expected to operate simultaneously is determined by the following factors:

- Possible flow of burning liquids between areas before or during operation of the water spray systems
- Possible flow of hot gases between fire areas that could actuate adjoining systems, increasing demand
- Flammable gas detection set to automatically actuate systems
- Manual operation of multiple systems
- Other factors that would result in operation of systems outside the primary fire area

Note: The hydraulically designed discharge rate for systems designed to operate simultaneously must not exceed the available water supply.

**12. Fire Department Connections**

A system fire department connection shall be provided on the system riser in accordance with NFPA 13. The fire department connection shall be of a brass body with an integral clapper assembly to separate flow between inlets. The fire department connection shall be installed in an area accessible for the first response unit. The fire department connection shall be listed for fire protection use. Refer to section 6.4.3 of NFPA 15 for exceptions where a fire department connection is not required.

**D. Hydraulic Calculations and Required Density**

Hydraulic calculations are required as part of the design of the piping system to determine that the required pressure and flow is available at each nozzle. Refer to section 8.3 of NFPA 15 for hydraulic calculation procedures. The minimum operating pressure of any nozzle protecting an outdoor hazard is 20 PSI (1.4 bar). Nozzles protecting interior hazards must have a minimum pressure in accordance with their listing. Refer to Table A on technical data page 208I and the appropriate sections for each type of material or equipment being protected for additional minimum density requirements.

**E. Exposure Protection of Transformers**

Power-generating plants contain many hazards that make water spray systems applicable for fire protection. Power transformers are one of the most common examples. Power transformers contain mineral oil in a transformer case to cool their electrical coils. The mineral oil has a flash point of 300 °F. Any source of overheating or metal failure can cause a fire that could destroy the transformer and threaten personnel and adjacent facilities.

Extinguishment/control mechanisms required for water spray protection of transformers include surface cooling, steam smothering, dilution, redirection, coating, and vapor exhaust. (Refer to B. General Requirements for a description of these methods).

**Design Process**

In order to perform a complete design of the water spray system for the protection of transformers, reference data must be obtained first. This includes the following:

- Transformer outline drawings from the manufacturer, which shows the dimensions of the transformer case, the locations and ratings of the transformer bushings, sizes and locations of cooling fins or radiators. The radiators have fans that blow cool air across the cooling fins





## TECHNICAL DATA

## DELUGE SPRINKLER SYSTEM

The Viking Corporation, 210 N Industrial Park Drive, Hastings MI 49058

Telephone: 269-945-9501 Technical Services 877-384-5464 Fax: 269-818-1680 Email: techsvcs@vikingcorp.com

in the radiator, cooling the hot oil. The drawings also show the location of the oil expansion tank, if applicable.

- Transformer structural drawings showing the transformer foundation, the oil drainage basin, and the transformer curb. These drawings also show any non-absorbing ground surface that requires water spray.
- A civil drawing or plot plan is used to reference the transformer to the deluge valve room and to help resolve underground conflicts if the piping is to be below grade.
- An architectural plan or fire protection plan to show how the transformer is positioned and oriented on the transformer foundation pad.

### Spray nozzle positioning

Nozzles must be aimed to sweep water across the top surface of the transformer case without spraying the bushings above the case or into the electric field of uninsulated bushings. The sweeping action is intended to remove standing oil from the top surface of the transformer. Verification of this positioning must be shown in a sectional view on the plan.

Refer to Viking technical data page 208h, section C. *Water Spray Protection for Transformers*. After the necessary information is obtained, the design process can begin. Follow the guidelines in technical data pages 208h-l and worksheet C on page 208s, and in section 7.4.4. of NFPA 15-2007 edition.

### Required density

Refer to Table A on technical data page 208l and section 7.4.4.3 of NFPA 15.

NFPA 15 requires a density of 0.25 gpm/ft<sup>2</sup> [10.2 (L/min) / m<sup>2</sup> for each square foot (or meter) of *rectangular prism* of the transformer, with *direct impingement* on all exposed surfaces of the transformer.

*Direct impingement* is where all surfaces are struck directly by water spray from the system.

A *rectangular prism* is an imaginary box, created by the waterspray system designer, that makes it unnecessary to calculate the surface area of minor discontinuities on the transformer tank and makes

it possible to consider radiators whose fins are less than 12" (305 mm) apart as a box. The designer uses this prism to calculate the surface area of each major transformer component and ensure that the minimum density is applied to all surfaces.

The transformer tank consists of four sides and a top, so it is a simple calculation. Appendages to the transformer case (radiators) consist of four sides, a top, and a bottom. The sides of the radiators may be calculated as rectangles if the radiator fins are spaced less than 12" (305 mm) apart.

NFPA 15 requires transformer components creating spaces over 12" (305 mm) wide to have their surfaces individually protected. This means that radiators with fins spaced greater than 12" must have nozzles located between each fin, with the surface area of each fin calculated. Care must be taken to make sure that details regarding fin spacing is available and that proper water spray application is provided.

Other appendages that require surface area calculation include control cabinets and expansion tanks. This is because of their ability to allow oil to form pools on the top of the cabinet surface, and their ability to block water spray from reaching the transformer tank behind and below the cabinet.

When a transformer is raised above the surface of the foundation pad, the bottom surface of the transformer must be wetted by water spray. Where there is insufficient clearance to achieve direct impingement, the surfaces underneath the transformer are permitted to be protected by horizontal projection or by nozzles directed to cool the area below the transformer projections.

New transformers are most often installed on foundations surrounded by gravel pits designed to collect any oil that may drip from a faulty transformer. One of the primary purposes for the water spray system is to push oil away from transformer surfaces and into the drainage pit. The water that sprays onto the transformer surface from the water spray system would also be collected in the pit. A procedure may be implemented to reclaim the oil through the use of an oil-water separator, which also allows reuse of the water.



## TECHNICAL DATA

## DELUGE SPRINKLER SYSTEM

The Viking Corporation, 210 N Industrial Park Drive, Hastings MI 49058

Telephone: 269-945-9501 Technical Services 877-384-5464 Fax: 269-818-1680 Email: techsvcs@vikingcorp.com

Older transformers or temporary transformers may be located on a non-absorbing concrete slab with no drainage pit. Without supplementary waterspray impingement protection of the concrete slab, there is potential for a pool fire around the transformer. NFPA 15 requires a minimum density of 0.15 gpm/ft<sup>2</sup> [6.1 (L/min) / m<sup>2</sup>] on the expected non-absorbing ground surface area of the exposure.

Note: The above density requirements are also required for special configurations, conservator tanks, pumps, etc. The water supply must be able to supply both the design flow rate and 250 gpm (946 L/min) for hose streams for a minimum of 1 hour.

Water spray piping is not allowed to be routed across the top of the transformer tank or across the face of the transformer cabinet. *Exception:* Where impingement can't be accomplished with any other configuration and the required distance from live electrical components is maintained.

Nozzles must be positioned so that the water spray doesn't envelop energized bushings or lightning arresters by direct impingement, except when authorized by the manufacturer and owner.

### F. Exposure Protection of Flammable Liquid Storage Tanks (Vessels)

Flammable liquid storage tanks present another common hazard in which require water spray system protection. Water spray is used to cool the surface area of the tank, tank supports, relief valves, and the liquid piping entry. Vessel failure is due to deformation of the metal, rupture of the tank shell, failure of the tank supports, or overpressurization caused by boiling of the liquid.

The flammable or combustible liquids stored in pressure vessels, low-pressure tanks, or atmospheric tanks have a *flash point* or temperature at which a flammable liquid ignites vapor from the fuel for a brief period. *Piloted ignition* is ignition and sustained combustion from an outside source, such as a spark or match, while *autoignition* is ignition and sustained combustion that could occur in cases where the fuel could ignite without an outside ignition source.

#### Defragation and Rupture

An extremely dangerous scenario could occur if the tank shell is heated by a fire beneath the tank and the heat is transferred to the liquid in the tank, igniting it and creating a defragation. A *defragation* is a fire that spreads at a velocity less than the speed of sound. Similarly, if a tank support or tank shell is heated to its failure point, the shell could deform and burst, resulting in a *rupture* and a serious defragation or an explosion. An *explosion* is the sudden overpressurization of the vessel beyond what it is capable of holding.

If a portion of the tank is unwetted by water spray, that portion of the tank surface can deform and lose strength, eventually rupture to cause a *BLEVE* (boiling liquid-expanding vapor explosion).

These scenarios result in extensive damage and can pose a threat to an entire *tank farm* (group of closely spaced tanks or vessels, sometimes located in pits or walled areas).

#### Pool fires

The accidental spill of the flammable liquid from the tank and the ignition of that liquid on the floor or ground below the tank results in a *pool fire*, or pool of burning flammable liquid. The impingement of flame upon the surface of the storage tank heats the flammable or combustible liquid in the tank. Water spray protection of vessels that store flammable liquids is greatly enhanced by applying water directly onto tank supports and the pool fire below the vessel. Direct water spray on a non-absorbing ground surface provides an extra level of protection for the vessel and its supports by directing water spray to the source of the hazard, by diluting the fuel, by surface cooling of the burning surface of the fuel, and by redirecting the fuel to a drain. Protection of non-absorbing ground area with water spray to extinguish the fire below the tank is an important part of exposure protection of the tanks.

#### Pool fire containment

Containment is necessary to prevent a running spill fire that would carry flammable liquid to other areas. The use of drains reduces the severity of pool fires:

- Drains to move the spilled flammable liquid to a location for reprocessing and reuse.



## TECHNICAL DATA

## DELUGE SPRINKLER SYSTEM

The Viking Corporation, 210 N Industrial Park Drive, Hastings MI 49058

Telephone: 269-945-9501 Technical Services 877-384-5464 Fax: 269-818-1680 Email: techsvcs@vikingcorp.com

- A wall or dike around the tank to contain the spilled liquid, with drains that have been designed to accept flaming flammable liquid.

### Pressure spray fires

Potential for ignition exists where pumps are used to move flammable liquid to or from the tank. A pump may overheat or burst a seal, spraying flammable liquid onto and beneath the tank. This could cause extreme damage to the storage vessel, personnel, the remaining contents of the vessel, and nearby vessels.

### Vessel protection mechanisms

- Exposure protection, with uniform application of water over the entire surface of the vessel. Water spray patterns at least meet or overlap, with consideration of obstructions to the water spray because even small unprotected areas could result in deformation of the tank wall and failure of the vessel.
- Surface cooling, which keeps the vessel cool in the event of a pressurized flammable or combustible liquid fire. Water spray is applied to the entire surface area and is critical for protecting the underside of the tank or vessel from pool fires.
- Prevention of boiling contents occurs as a result of water spray application, which reduces heat absorption from pool fires.

### Design procedures and spray nozzle positioning

Refer to Viking technical data page 208a-r, *Water Spray Protection for Horizontal and Vertical Tanks*. Necessary information must first be obtained regarding the tank and its surroundings, and then the design process can begin. Also refer to Chapter 7 of NFPA 13-2007 edition for design requirements.

### Required Density

Refer to Table A on technical data page 208I and sections 7.4.2.1 and 7.4.2.6 of NFPA 15.

NFPA 15 requires water spray to be applied to vessel surfaces (including top and bottom of vertical vessels) at a minimum net rate of 0.25 gpm/ft<sup>2</sup> [10.2 (L/min) / m<sup>2</sup> of exposed surface.

NOTE: The density requirement for tanks is the same as for transformers because they both share the same performance objective of exposure protection.

In addition to exposure protection of the vessel, water spray protection should be considered for any tank supports or structural elements. This is to prevent the supports from buckling from the heat from a pool fire. Extra nozzles aimed directly at the supports provide complete water spray protection.

### Total Water Requirement

The total water requirement at the base of the riser is determined by hydraulic calculations, which must take into account frictional losses in pipe, pressure imbalances in the system, elevation losses, water wastage, and the additional water spray for protecting vessel supports or non-absorbing ground surface. *Water wastage* refers to water not striking the surface, thus providing less density to the surface of the vessel than is actually flowing from the spray nozzles. Water wastage is caused by overspray, where water misses the vessel surface, or wind wastage. NFPA 15 includes a safety factor in the density requirements, and assumes that wastage doesn't exceed 0.05 gpm/ft<sup>2</sup> [2.0 (L/min) / m<sup>2</sup>.

## **G. Exposure Protection of Structural Steel**

Water spray systems can be used to protect structural steel in buildings from fire exposure, however it is more common for protection of pipe racks and other miscellaneous structures in the petrochemical industry.

### Required Density (Refer to Figure 7.4.3.1 in NFPA 15)

Section 7.4.3.1 of NFPA 15 states that horizontal primary structural steel members must be provided with spray nozzle protection having a net discharge rate of at least 0.10 gpm/ft<sup>2</sup> [4.1 (L/min) / m<sup>2</sup> over the wetted area.



The Viking Corporation, 210 N Industrial Park Drive, Hastings MI 49058

Telephone: 269-945-9501 Technical Services 877-384-5464 Fax: 269-818-1680 Email: techsvcs@vikingcorp.com

Vertical structural steel members must be provided with spray nozzle protection having a net discharge rate of at least 0.25 gpm/ft<sup>2</sup> [10.2 (L/min) / m<sup>2</sup> over the wetted area.

The water spray should completely cover the flange and web of the structural member, with nozzles positioned on alternate sides of the beam.

Water spray exposure protection is not required for structural steel encased in fire-resistant insulating material acceptable to the Authority Having Jurisdiction.

Per NFPA 15, water spray exposure protection is not required for where the following calculations exist and are acceptable to the Authority Having Jurisdiction:

- The structural steel has been analyzed and determined to withstand a fire of the worst-case scenario, through calculations done by a registered professional engineer.
- Calculations verify that the temperature of the steel members does NOT exceed that which would compromise structural integrity.

## H. Exposure Protection of Metal Pipe, Tubing, and Conduit

Metal pipe, tubing, and conduit in racks may require water spray system protection from a spill fire or other exposure. Per section 7.4.3.7 of NFPA 15, the water spray must be directed at the underside of the pipes, tubes, and conduit. The nozzles must be located within 2-1/2 ft (0.8 m) below the bottom of the level being protected. NOTE: Water must be applied to the underside of the top level even if located immediately above a protected level.

*Exception:* Water spray is permitted to be applied to the top of pipes on racks where water spray piping cannot be installed below the rack due to the potential of physical damage or where space is inadequate for proper installation.

Obstructions: Where the rack horizontal support members create an obstruction to the spray pattern, nozzles must be spaced within the bays.

Vertical structural supports are required to be protected in accordance with the requirements for vertical structural steel.

Required density (refer to Table 1 below)

<b>TABLE 1: Metal Pipe, Tubing, and Conduit - Density Requirements</b>					
Number of Rack Levels	Plan View Density at Lowest Level		Plan View Density at Upper Level(s)*		Levels Requiring Nozzles
	GPM/ft <sup>2</sup>	(L/min) / m <sup>2</sup>	GPM/ft <sup>2</sup>	(L/min) / m <sup>2</sup>	
1	0.25	10.2	N/A	N/A	All
2	0.20	8.2	0.15	6.1	All
3-5	0.20	8.2	0.15	6.1	Alternate
6 +	0.20	8.2	0.10	4.1	Alternate
*Table values are applicable for exposure protection from a spill fire.					
NOTE: This table is found in NFPA 15-2007 edition, Table 7.4.3.7.3.					

Vertically stacked piping must be protected by water spray directed at one side (vertical plane) of the piping at a minimum net rate of 0.15 gpm/ft<sup>2</sup> [6.1 (L/min) / m<sup>2</sup>.

## I. Exposure Protection of Cable Trays and Cable Runs

This type of water spray system is for protection of insulated wire, cable, or non-metallic tubing in open trays or runs from a spill fire or other exposure. NFPA 70, *National Electrical Code* defines a *cable tray system* as a unit or assembly of units or sections and associated fittings forming a rigid structural system used to securely fasten or support cables and raceways.



## TECHNICAL DATA

DELUGE SPRINKLER  
SYSTEM

The Viking Corporation, 210 N Industrial Park Drive, Hastings MI 49058

Telephone: 269-945-9501 Technical Services 877-384-5464 Fax: 269-818-1680 Email: techsvcs@vikingcorp.com

#### Required density

NFPA 15 (section 7.4.3.8) requires that a net rate of at least 0.30 gpm/ft<sup>2</sup> [12.2 (L/min) / m<sup>2</sup>] of projected horizontal or vertical plane area containing the cables or tubes must be provided. The nozzles must be arranged to spray this rate both over and under (or to the front and rear of) cable or tubing runs and to the racks and supports.

Where other water spray nozzles are arranged to extinguish (see section J below), control, or cool exposing liquid surfaces, the water spray density is permitted to be reduced to a minimum net rate of 0.15 gpm/ft<sup>2</sup> [6.1 (L/min) / m<sup>2</sup>] over the upper surface, front, or back of the cable or tubing tray or run.

#### Flame shield use

The water density is allowed to be reduced to a minimum rate of 0.15 gpm/ft<sup>2</sup> [6.1 (L/min) / m<sup>2</sup>] over the upper surface of the cable or rack, where flame shields equivalent to 1/16" (1.6 mm) thick steel plate are mounted below cable or tubing runs. The flame shield or steel plate must be wide enough to extend at least 6" (152 mm) beyond the side rails of the tray or rack in order to deflect flames or heat emanating from spills below cable or conduit runs.

### **J. Fire Extinguishment Protection of Cable Trays and Cable Runs**

For cable trays and cable runs, the cable insulation is considered to be the source of fuel and propagates the fire. The automatic water spray (open nozzle) system protects insulated wire and cable or nonmetallic tubing by extinguishment of the fire that originates within the cable or tube.

#### Required Density

Per section 7.2.2 of NFPA 15, the system must be hydraulically designed to impinge water directly on each tray or group of cables or tubes at a net rate of 0.15 gpm/ft<sup>2</sup> [6.1 (L/min) / m<sup>2</sup>] on the projected plane containing the cable or tubing tray or run. Other water spray densities and methods of application are permitted where tests verify this is acceptable and where acceptable to the Authority Having Jurisdiction.

#### Detection devices

Cable fires typically create substantial products of combustion with little heat release. Automatic detection devices that detect smoke as opposed to heat are required.

Note: If there is likelihood that spills of flammable liquids or molten materials will expose cables, non-metallic tubing, and tray supports, the system must be designed for exposure protection as described in the next section.

### **K. Fire Extinguishment Protection of Belt Conveyors**

Conveyors are often used in power plants; for example when transporting fuel such as coal to a steam boiler. The coal conveyor requires water spray protection for the fuel that is transported on the top belt. Below the top belt is the return belt, which also requires water spray protection. These belts can ignite if a belt roller stops rotating, creating friction with the belt, and creating a possible ignition scenario when the conveyor stops and the belt is heated by the defective belt roller. A fire moving on a conveyor belt creates a hazard that requires water spray. This hazard can be reduced if the conveyor can be stopped once the water spray system operates.

Note: NFPA 850 (section 7.4.4), *Recommended Practice for Fire Protection for Electric Generating Plants and High Voltage Direct Current Converter Stations*, recommends that conveyor belts be made of fire-resistant material in accordance with recommendations by the U.S. Mine Safety and Health Administration. However, "fire retardant" materials can still burn, necessitating protection. Per NFPA 15, section 7.2.3.3, open nozzles are required to be located to spray water onto the surfaces to extinguish fire in hydraulic oil, the belt and its contents, or the drive unit. Water spray impingement on structural elements must provide exposure protection against radiant heat or impinging flame.

Interlocks are required between the detection system and the machinery to shut down belt conveyor operation, including upstream feed.

**TECHNICAL DATA****DELUGE SPRINKLER  
SYSTEM**

The Viking Corporation, 210 N Industrial Park Drive, Hastings MI 49058

Telephone: 269-945-9501 Technical Services 877-384-5464 Fax: 269-818-1680 Email: techsvcs@vikingcorp.com

### Drive unit

The water spray system must extend protection to the drive rolls, the take-up rolls, the power units, and the hydraulic-oil unit. The minimum required net rate of water application for the drive unit is 0.25 gpm/ft<sup>2</sup> [10.2 (L/min) / m<sup>2</sup> of roll and belt (section 7.2.3 of NFPA 15).

### Conveyor belt

Per NFPA 15, water spray protection must accomplish one of the following:

- Extend onto transfer belts, transfer equipment, and transfer building.
- Interlock in a manner so that the water spray system protecting the feeding belt will automatically actuate the water spray system protecting the first segment of the downstream equipment.

The water spray system must be installed to automatically wet the top of the conveyor belt, its contents, and the bottom return belt. The nozzle discharge patterns must envelop the top and bottom of the belt surface area, conveyor surfaces where combustible materials are likely to accumulate, the structural parts, and the idler rolls supporting the belt, at a minimum required net rate of 0.25 gpm/ft<sup>2</sup> [10.2 (L/min) / m<sup>2</sup>.

Note: The water supply must be capable of supplying both the design flow rate and 250 gpm (946 L/min) for hose streams for a minimum of 1 hour.

## **L. Control of Burning**

Water spray systems can be used for control of burning involving many different types of equipment. Equipment that is commonly protected with a control of burning strategy includes pumps, compressors, fuel pulverizers, turbine generators, hydraulic control systems, and lube oil systems, that handle flammable and combustible liquids or gases.

The water spray system must allow sufficient time for one of the following:

- For the burning material to be consumed.
- For steps to be taken to shut off the flow of leaking material.
- For burning material to be otherwise extinguished.

The nozzles must be positioned to impinge water directly on the areas of the source of fire and where spills are likely to spread or accumulate.

### **1. Pumps, Compressors, and Related Equipment**

Oil pumps supply pressurized oil to lubricate the bearings of steam turbines used in power plants. Pumps or other devices that handle flammable liquids or gases must have the shafts, seals, and other critical parts enveloped by directed water spray at a net rate of at least 0.50 gpm/ft<sup>2</sup> [20.4 (L/min) / m<sup>2</sup> of projected surface area of the equipment per section 7.3.2 of NFPA 15.

### **2. Flammable and Combustible Liquid Pool Fires**

Water spray systems are used to control pool fires resulting from a flammable or combustible liquid spill fire. (For example, extinguishment of pool fires above and below condensers used in power plants where lube oil drips or sprays from turbine bearings if their seals fail.) The minimum required net application rate per section 7.3.3 of NFPA 15 is 0.30 gpm/ft<sup>2</sup> [12.2 (L/min) / m<sup>2</sup> of protected area.

## **M. Prevention of Fire**

The water spray system must allow sufficient time to dissolve, dilute, disperse, or cool flammable vapor, gases, or other hazardous materials. The duration of the release of flammable materials is required to be added to the water spray duration. The minimum net rate of application is to be based on field experience with the product or on actual test data.



The Viking Corporation, 210 N Industrial Park Drive, Hastings MI 49058  
 Telephone: 269-945-9501 Technical Services 877-384-5464 Fax: 269-818-1680 Email: techsvcs@vikingcorp.com

## N. Automatic Detection Systems and Equipment

Unlike wet pipe and dry pipe systems, water spray systems using open nozzles cannot be actuated by a loss of pressure in the piping system. Therefore, water spray systems require a detection system that supervises the area being protected and that will actuate the sprinkler system when a fire is detected. Detection systems providing an actuation signal to fixed water spray systems are required to be selected, designed, and installed in accordance with NFPA 72 National Fire Alarm Code. Automatic detection equipment, release devices, and system accessories must be listed for the intended use. An alarm is required to be actuated by the operation of the detection system, independent of system water flow.

The following data must be evaluated when selecting and adjusting detection equipment:

- Manufacturer's recommendations
- Detector's listing criteria
- Nature of the hazard being protected
- Air velocities (both normal and abnormal)
- Range of anticipated temperatures
- Maximum expected rates of temperature change under non-fire conditions
- Number and height of structural levels
- Effects of precipitation (rain and snow)
- Presence of obstructions that might delay detection
- Any other conditions that could negatively affect fire detection

Two types of detection systems can be considered: electrical detection systems and pilot head detection systems:

1. Electric detection systems use detectors to send an electronic signal to the control panel when a fire is detected. The control panel then sends an electric signal to a solenoid, electrically opening the deluge valve and allowing water to flow into the water spray system. There are several types of electric detectors with different functions:
  - a. Heat detectors measure the temperature of the air in the vicinity of the detector and send a signal to the control panel. Fixed-temperature detectors send a signal when the detector reaches a predetermined temperature.
  - b. Rate-compensating detectors measure the rate of temperature rise and send a signal to the control panel when the temperature rises to a predetermined rate of temperature change within a predetermined time. These detectors are very reliable for exterior transformer and tank protection because gradual fluctuations in temperature would not affect the detection system.
  - c. A linear heat detection system uses heat-sensitive wiring that may be installed around a transformer loop. When the wiring senses heat, the current flow in the wiring changes. When the current flow changes a predetermined amount, the control panel sends a signal to a switch on the deluge valve that activates the water spray system. This detection system is especially effective on linear hazards, such as coal conveyors and cable tray protection, but have also been found to be effective for transformers and vessels. Note: Smoke detectors and beam detectors are not suited for exterior exposures.
2. Pilot head detection systems consist of closed sprinklers (pilot heads) on a loop of 1/2" pilot piping supported from the transformer loop. The pilot piping is pressurized with air and is connected to a supervisory air pressure switch. In areas not subject to freezing, a wet pilot system is used where the pilot piping is pressurized with water, and in areas where freezing could occur, the pilot line is pressurized with air. The temperature rating of pilot-type sprinklers is selected in accordance with the requirements for automatic sprinklers in NFPA 13.



## TECHNICAL DATA

DELUGE SPRINKLER  
SYSTEM

The Viking Corporation, 210 N Industrial Park Drive, Hastings MI 49058

Telephone: 269-945-9501 Technical Services 877-384-5464 Fax: 269-818-1680 Email: techsvcs@vikingcorp.com

#### Detector protection

Detection equipment installed outdoors or in potentially corrosive atmospheres must be protected. A protective canopy may be required for protection from the weather. Detection equipment must be protected from mechanical damage.

#### Installation Requirements and Detector Spacing, and Response Time

Detectors must be supported independently of their attachment to wires or tubing. The spacing, location, and position of detectors are required to be in accordance with section 6.5.2 of NFPA 15.

Detectors must be located to promptly respond to a fire, flammable gas release, or other design conditions. The detection system must be designed to cause operation of the deluge valve without delay. Where ambient conditions cause false system operations, detection systems are permitted to include delays that would override these conditions. The detection system must be capable of detecting a fire up to the elevation of the highest level of protected equipment surface. No portion of the hazard being protected may extend beyond the perimeter line of detectors.

#### Outdoor detector spacing

Spacing of fixed temperature or rate-of-rise detectors located outdoors or out in the open must be reduced by at least 50% from the listed spacings under smooth ceilings, unless testing indicates other spacings are acceptable or unless the detectors are specifically listed for outdoor installation with other spacing guidelines.

#### Pilot-type sprinkler spacing for indoor locations

Maximum horizontal spacing for indoor locations is 12 ft (3.7 m). Where located under a ceiling, pilot sprinklers must be positioned in accordance with the requirements for automatic sprinklers in NFPA 13, unless specifically listed for other spacing.

The obstruction to water distribution rules for automatic sprinklers is not required where pilot sprinklers are used. Pilot sprinklers are permitted to be spaced more than 22" (559 mm) below a ceiling or deck where the maximum spacing between pilot sprinklers is 10 ft (3 m) or less.

#### Pilot-type sprinkler spacing for outdoor locations

Pilot sprinklers located outdoors, such as in open process structures, are to be spaced such that the elevation of a single level of pilot sprinklers and between additional levels of pilot sprinklers does not exceed 17 ft (5.2 m).

The maximum horizontal distance between pilot sprinklers installed outdoors is 8 ft (2.5 m). *Exception:* The maximum horizontal distance may be increased to 10 ft (3 m) where ALL of the following exist:

- The elevation of the first level doesn't exceed 15 ft (4.6 m).
- The distance between additional levels doesn't exceed 12 ft (3.7 m).
- The pilot sprinklers are staggered vertically.

Other vertical pilot sprinkler spacings are permitted when listed for other spacings.

#### Special situations

Open-sided buildings: Detectors located in open-sided buildings are required to follow the indoor spacing rules. A line of detectors in accordance with the outdoor detector spacing rules must be located along the open sides of open-sided buildings.

Under open gratings: Detectors under open gratings are to be spacing in accordance with the rules for outdoor detector spacing.

Two or more systems: Where there are two or more adjacent water spray systems in one area controlled by separate detection systems, the detectors on each system must be spaced independently as if the dividing line between the systems were a wall or draft curtain.





## TECHNICAL DATA

## DELUGE SPRINKLER SYSTEM

The Viking Corporation, 210 N Industrial Park Drive, Hastings MI 49058

Telephone: 269-945-9501 Technical Services 877-384-5464 Fax: 269-818-1680 Email: techsvcs@vikingcorp.com

Flammable gas detectors: These detectors must be located with consideration of the density of the flammable gas, its temperature, and proximity to equipment where leakage is more likely to occur. Access for testing, calibration, and maintenance of flammable gas detectors is required.

Radiant energy-sensing fire detectors: These detectors must be spaced and located in accordance with their listings and manufacturer's recommendations.

### O. Water Spray System Maintenance

Water spray systems installed in accordance with NFPA 15 shall be properly maintained in accordance with NFPA 25 and NFPA 72 to provide at least the same level of performance and protection as designed. The owner is responsible for conducting system maintenance and maintaining the system in operating condition.

## XVII. PLACING THE DELUGE SYSTEM IN SERVICE

**NOTE: FOR NEW INSTALLATIONS, REFER TO INSTRUCTIONS PROVIDED IN TECHNICAL DATA DESCRIBING THE VIKING DELUGE VALVE AND OTHER SYSTEM COMPONENTS.**

To Return a System to Service (Figures 50-51):

1. Verify that the system has been properly drained. Auxiliary drain should be open. Verify that emergency release is closed. The priming valve should be closed.
2. For hydraulic release systems: Verify that the inspectors test valve and any auxiliary drains on the release system are closed.
3. Open the priming valve to establish pressure in the priming chamber and the release system. Verify that the pressure indicated on priming pressure water gauge indicates that the priming chamber is pressurized with system water supply pressure.
4. For pneumatic release systems: Restore pneumatic pressure to release system. Maintain 30 PSI (2 bar) or 50 PSI (3.4 bar) as required by the pneumatic actuator. Prime pressure will be restored to the priming chamber of the deluge valve.

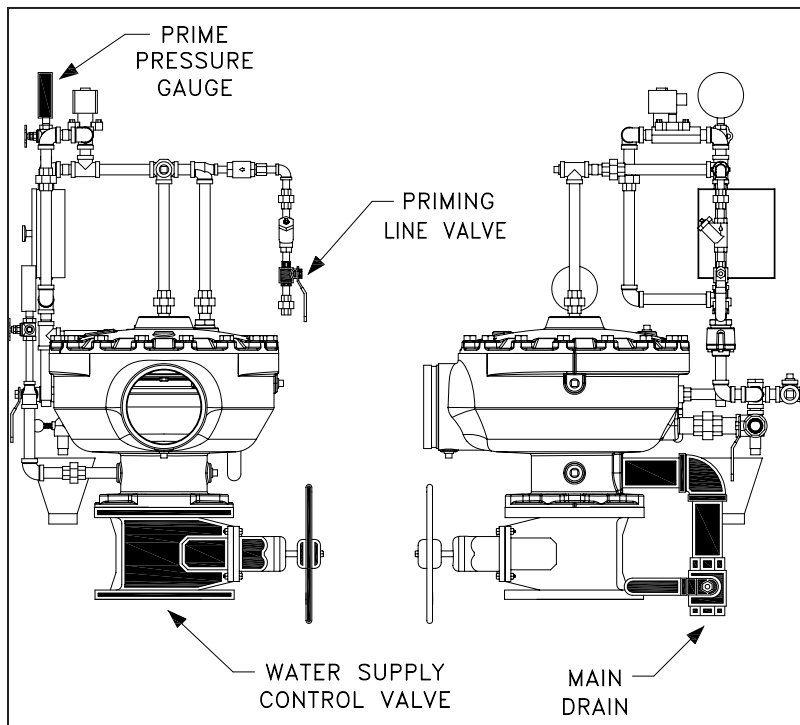


Figure 50

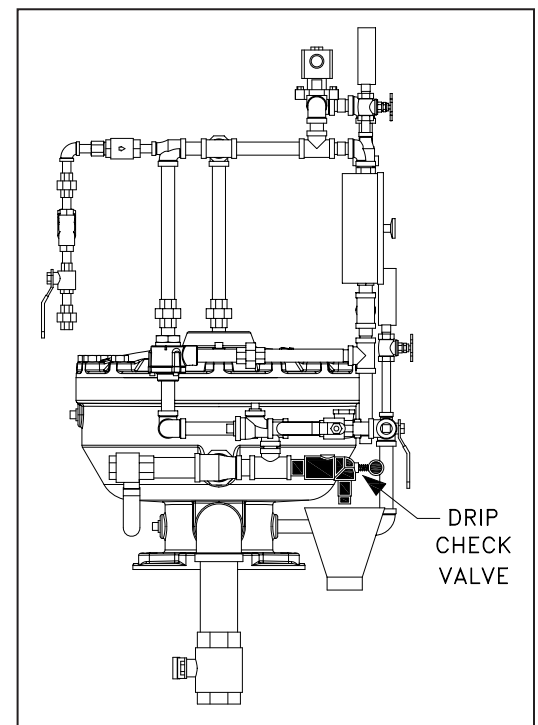


Figure 51



## TECHNICAL DATA

## DELUGE SPRINKLER SYSTEM

The Viking Corporation, 210 N Industrial Park Drive, Hastings MI 49058

Telephone: 269-945-9501 Technical Services 877-384-5464 Fax: 269-818-1680 Email: techsvcs@vikingcorp.com

5. For electric release systems: Reset the system control panel. For the Viking Release Control Panel, open the panel and press "RESET". Solenoid valve should close. Flow from the solenoid valve to the drain cup should stop.
6. Open the flow test valve.
7. Partially open the main water supply control valve.
8. When full flow develops from flow test valve, close the flow test valve. Verify that there is no flow from the open auxiliary drain.
9. Close the auxiliary drain.
10. Fully open and secure the main water supply control valve.
11. Verify that the alarm shut-off valve is open and that all other valves are in their normal operating position.
12. Depress the plunger of the drip check. No water should flow from the drip check when the plunger is pushed.

## XVIII. DELUGE SYSTEM INSPECTIONS, TESTS, AND MAINTENANCE

**NOTICE: THE OWNER IS RESPONSIBLE FOR MAINTAINING THE FIRE-PROTECTION SYSTEM AND DEVICES IN PROPER OPERATING CONDITION. THE DELUGE VALVE MUST BE KEPT FROM FREEZING CONDITIONS AND PHYSICAL DAMAGE THAT COULD IMPAIR ITS OPERATION.**

**WARNING: ANY SYSTEM MAINTENANCE THAT INVOLVES PLACING A CONTROL VALVE OR DETECTION SYSTEM OUT OF SERVICE MAY ELIMINATE THE FIRE-PROTECTION CAPABILITIES OF THAT SYSTEM. PRIOR TO PROCEEDING, NOTIFY ALL AUTHORITIES HAVING JURISDICTION. CONSIDERATION SHOULD BE GIVEN TO EMPLOYMENT OF A FIRE PATROL IN THE AFFECTED AREAS.**

It is imperative that the system be inspected and tested on a regular basis in accordance with NFPA 25. During all inspections, testing, and maintenance activities the valve, trim, piping, alarm devices, and connected equipment must be visually inspected for foreign matter, physical damage, freezing, corrosion, or other conditions that may inhibit the proper operation of the system.

The following recommendations are minimum requirements. The frequency of the inspections may vary due to contaminated or corrosive water supplies and corrosive atmospheres. In addition, the alarm devices, detection systems, or other connected equipment may require more frequent inspections. Refer to the system description, sections in this manual specifically for each component of the system and type of release system, applicable codes, and the authority having jurisdiction for minimum requirements. Prior to testing the equipment, notify appropriate personnel.

Weekly visual inspection of the Viking deluge valve is recommended.

1. Verify that the main water supply control valve is open and that all other valves are in their normal operating position and appropriately secured. For normal operating position, refer to trim charts and system data for the system used.
2. Check for signs of mechanical damage, leakage, and/or corrosive activity. If detected, perform maintenance as required. If necessary, replace the device.
3. Verify that the valve and trim are adequately heated and protected from freezing and physical damage.

### A. Quarterly Water Flow Alarm Test

Quarterly testing of water flow alarms and performance of a main drain test is recommended and may be required by the Authority Having Jurisdiction.

1. Notify the Authority Having Jurisdiction and those in the area affected by the test.
2. To test the local electric alarm (if provided) and/or mechanical water motor alarm (if provided), OPEN the alarm test valve in the deluge valve trim.
  - a. Electric alarm pressure switches (if provided) should activate.
  - b. Electric local alarms should be audible.
  - c. The local water motor gong should be audible.



## TECHNICAL DATA

## DELUGE SPRINKLER SYSTEM

The Viking Corporation, 210 N Industrial Park Drive, Hastings MI 49058

Telephone: 269-945-9501 Technical Services 877-384-5464 Fax: 269-818-1680 Email: techsvcs@vikingcorp.com

- d. If equipped with remote station alarm signaling devices, verify that alarm signals were received.
3. When testing is complete, CLOSE the alarm test valve.
4. Verify:
  - a. All local alarms stop sounding and alarm panels (if provided) reset.
  - b. All remote station alarms reset.
  - c. Supply piping to water motor alarm properly drains.
5. Verify that the alarm shut-off valve is OPEN, and the alarm test valve is CLOSED.
6. Verify that the outlet chamber is free of water. No water should flow from the drip check when the plunger is pushed.
7. Notify the Authority Having Jurisdiction and those in the affected area that testing is complete.

### B. Quarterly Main Drain Test

1. Notify the Authority Having Jurisdiction and those in the area affected by the test.
2. Record pressure reading from the water supply pressure gauge.
3. Verify that the outlet chamber of the deluge valve is free of water. No water should flow from the drip check when the plunger is pushed.
4. Fully OPEN the flow test valve.
5. When a full flow is developed from the flow test valve, record the residual pressure from the water supply pressure gauge.
6. When the test is complete, SLOWLY CLOSE the flow test valve.
7. Compare test results with previous flow information. If deterioration of the water supply is detected, take appropriate steps to restore adequate water supply.
8. Verify:
  - a. Normal water supply pressure has been restored to the inlet chamber, the priming chamber, and the release system. The pressure on the priming chamber water pressure gauge should equal the system water supply pressure.
  - b. All alarm devices, and valves are secured in normal operating position. For normal operating position, refer to trim charts and system data for the system used.
9. Notify the Authority Having Jurisdiction that the test is complete. Record and/or provide notification of test results as required by the Authority Having Jurisdiction.

### C. Annual Trip Test

Caution! Performing this test results in operation of the deluge valve. Water will flow into the sprinkler piping and from any open sprinklers and/or nozzles. Take necessary precautions to prevent damage.

1. Notify the Authority Having Jurisdiction and those in the area affected by the test.
2. Fully open the flow test valve to flush away any accumulation of foreign material.
3. Close the flow test valve.
4. Trip the system by operating the release system. Allow a full flow to pass through the deluge valve. Water flow alarms should operate.
5. When test is complete:
  - a. Close the main water supply control valve.
  - b. Close the priming valve.
  - c. Open the auxiliary drain valve.
  - d. Open all system main drains and auxiliary drains. Allow the system to drain completely.
6. Perform SEMI-ANNUAL maintenance.
7. Place the system in service. Refer to INSTALLATION: PLACING THE VALVE IN SERVICE.

**TECHNICAL DATA****DELUGE SPRINKLER  
SYSTEM**

The Viking Corporation, 210 N Industrial Park Drive, Hastings MI 49058

Telephone: 269-945-9501 Technical Services 877-384-5464 Fax: 269-818-1680 Email: techsvcs@vikingcorp.com

**NOTE:** Deluge valves supplied by brackish water, salt water, foam, foam/water solution, or any other corrosive water supply should be flushed with good quality fresh water before being returned to service.

8. Notify the Authority Having Jurisdiction that the test is complete. Record and/or provide notification of test results as required by the Authority Having Jurisdiction.

## D. Maintenance

Where difficulty in performance is experienced, the valve manufacturer or his authorized representative shall be contacted if any field adjustment is to be made.

### After Each Operation

1. Sprinkler systems that have been subjected to a fire must be returned to service as soon as possible. The entire system must be inspected for damage, and repaired or replaced as necessary.
2. Deluge valves and trim that have been subjected to brackish water, salt water, foam, foam/water solution, or any other corrosive water supply should be flushed with good quality fresh water before being returned to service.
3. Perform SEMI-ANNUAL maintenance after every operation.

### Semi-Annual Maintenance

1. Remove the system from service. (Refer to deluge system data that describes systems with the release system used for additional information.)
  - a. Close the main water supply control valve and priming valve.
  - b. Open the auxiliary drain valve.
  - c. Relieve pressure in the priming chamber by opening the emergency release valve.
2. Inspect all trim for signs of corrosion and/or blockage. Clean and/or replace as required.
3. Clean and/or replace all strainer screens. Note: The screen in the priming line strainer must be cleaned from time to time and the other devices in the priming line may need to be replaced as well. The plug on the strainer provides access to visually check the screen. The plug should not be removed while the system is under pressure.
4. For Halar® coated deluge valves, check the Halar® coating for physical damage. If necessary, make repairs to the affected area to inhibit potential corrosion. Refer to the paragraph below - Halar® Coating Repair instructions.
5. Refer to PLACING THE VALVE IN SERVICE.

### Every Fifth Year

1. Internal inspection of deluge valves is recommended every five years unless inspections and tests indicate more frequent internal inspections are required. Refer to DISASSEMBLY instructions provided below.
2. Internal inspection of strainers and restricted orifices is recommended every five years unless inspections and tests indicate more frequent internal inspections are required.
3. Record and provide notification of inspection results as required by the Authority Having Jurisdiction.

### Halar® Coating Repair

If the Halar® coating becomes chipped, immediately repair the damaged area to inhibit the potential for corrosion. Follow instructions below:

1. Wipe clean and prepare the area to be repaired as instructed.
2. Using a hand held torch, gently heat the Halar® coating around the area needing repair to the melting point of the Halar®.
3. Allow the heated Halar® to flow together.
4. Allow the coating to cool as directed in the instructions.

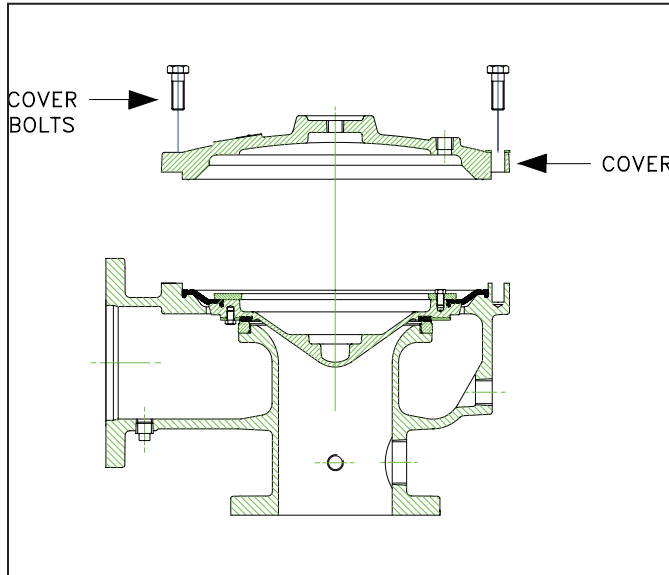


## TECHNICAL DATA

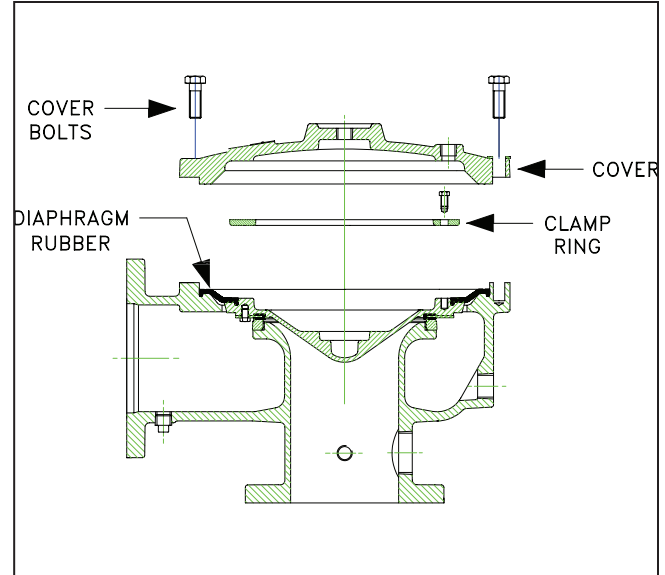
## DELUGE SPRINKLER SYSTEM

The Viking Corporation, 210 N Industrial Park Drive, Hastings MI 49058

Telephone: 269-945-9501 Technical Services 877-384-5464 Fax: 269-818-1680 Email: techsvcs@vikingcorp.com



**Figure 52**



**Figure 53**

### Valve Disassembly (Figures 52-53)

1. Remove the valve from service.
  - a. Close the main water supply control valve and priming valve.
  - b. Open the auxiliary drain valve.
  - c. Release the pressure in the priming chamber by opening the emergency release valve.
2. Disconnect and remove necessary trim from the cover and remove cap screws.

*For 2" through 8" deluge valves only:*

3. Lift cover from body.
4. Remove the clapper assembly by lifting it from body.
5. Inspect seat. If replacement is necessary, do not attempt to separate it from body. The seat is not removeable.
6. To replace the diaphragm rubber, remove the circle of screws. Remove the clamp ring. The diaphragm rubber can be removed.
7. To replace the seat rubber assembly, the clapper assembly must be removed from the valve (see Step 3 above). Remove the circle of screws. The seat rubber assembly can be removed.

*For 1-1/2" deluge valves only:*

3. Lift the cover from the spacer.
4. Remove the spacer and the rolling diaphragm and clapper assembly from the body.
5. To replace the clapper assembly, remove the screw and sealing-washer assembly. Install the new clapper assembly and discard the old.
6. To replace the lower diaphragm, remove the screw and sealing-washer assembly, and the clapper. Install the new diaphragm and discard the old.
7. To replace the upper diaphragm rubber, remove the screw and sealing-washer assembly, and the clamp plate. Install the new diaphragm and discard the old.

**NOTE: PRIOR TO INSTALLING A NEW DIAPHRAGM RUBBER, SEAT RUBBER OR LOWER DIAPHRAGM, MAKE CERTAIN THAT ALL SURFACES ARE CLEAN AND FREE OF FOREIGN MATTER. THE SEAT MUST BE SMOOTH AND FREE OF NICKS, BURRS OR INDENTATIONS.**

**NOTE: THE CLAPPER RUBBER MUST BE INSTALLED WITH THE RIDGE ON THE CLAPPER RUBBER FACING TOWARDS THE CLAPPER.**



## TECHNICAL DATA

## DELUGE SPRINKLER SYSTEM

The Viking Corporation, 210 N Industrial Park Drive, Hastings MI 49058

Telephone: 269-945-9501 Technical Services 877-384-5464 Fax: 269-818-1680 Email: techsvcs@vikingcorp.com

### Valve Reassembly

1. Prior to reassembly, flush the valve of all foreign matter. The valve seat must be clean and free from all marks and scratches.
2. To reassemble, reverse disassembly procedure.

#### *For the 1-1/2" deluge valves only:*

3. When installing diaphragms, care must be taken to assure all bolt holes are aligned. Also, the fabric side (rough side) of the diaphragms must be positioned toward piston. Prior to tightening screws, install the clapper assembly into the spacer.
  - a. Insert the upper diaphragm through the opening in spacer from the bottom surface of the spacer to the top. The clapper assembly must be toward the inlet chamber of the valve.

**NOTE: THE SPACER'S OUTSIDE DIAMETER IS TAPERED. THE DIAMETER OF THE BOTTOM IS GREATER THAN THE DIAMETER OF THE TOP.**

- b. Align bolt holes and tighten screws.
4. Place the cover, with cap screws inserted in the holes, upside down on a work bench.
5. With the top side of the spacer and upper diaphragm toward the cover, place the clapper assembly and spacer, described in Step 3, over the threaded ends of cap screws.
  - a. Upper diaphragm must be flat between the cover and spacer.
  - b. The piston should protrude from the spacer, and the clapper assembly should be visible (facing up).
6. Gently roll the lower diaphragm over the protruding piston and position the bolt holes of the lower diaphragm over the threaded ends of the cap screws.
7. Taking care not to cut the diaphragm, tuck the lower diaphragm between the spacer and piston around the entire circumference of the piston while gently pushing the piston into the spacer.
8. Carefully position the cover with cap screws and piston assembly on the valve body.
9. Remove the cover with cap screws and verify that upper diaphragm is properly tucked between the spacer and piston around the entire circumference of the piston.
10. Install cover and cap screws.
  - a. Lower diaphragm must be flat between the spacer and body.
  - b. Cross tighten cap screws uniformly. Do not over-tighten.
11. The valve must be operated after reassembly to verify all parts function properly.

## XIX. REMOVING THE SYSTEM FROM SERVICE

**WARNING:** The system should be placed out of service only for repairs. The work must be completed in a manner to minimize the time that the system must be out of service. All hazardous activities in the effected area shall be terminated until the system is placed back in service. Any system impairment shall be coordinated with the owner, local authority having jurisdiction, and other related parties. Place a roving fire patrol in the area covered by the system until the system is back in service.

**Prior to turning off any valves or activating any alarms, notify local security guards and/or central alarm station (if used) so that a false alarm will not be signalled and result in a local fire department response.**

1. Close the water supply control valve.
2. Close the priming valve.
3. Open all auxiliary drain valves and inspectors test valve.
4. Silence alarms (optional). To silence electric alarms controlled by pressure switch and to silence water motor alarm, close alarm shut-off valve.



## TECHNICAL DATA

## DELUGE SPRINKLER SYSTEM

The Viking Corporation, 210 N Industrial Park Drive, Hastings MI 49058

Telephone: 269-945-9501 Technical Services 877-384-5464 Fax: 269-818-1680 Email: techsvcs@vikingcorp.com

**NOTE: ELECTRIC ALARMS CONTROLLED BY A PRESSURE SWITCH INSTALLED IN THE ½" (15 MM) NPT CONNECTION FOR A NON-INTERRUPTIBLE ALARM PRESSURE SWITCH CANNOT BE SHUT OFF UNTIL THE DELUGE VALVE IS RESET OR TAKEN OUT OF SERVICE.**

**NOTE: SPRINKLER SYSTEMS THAT HAVE BEEN SUBJECTED TO A FIRE MUST BE RETURNED TO SERVICE AS SOON AS POSSIBLE. THE ENTIRE SYSTEM MUST BE INSPECTED FOR DAMAGE, AND REPAIRED OR REPLACED AS NECESSARY.**

5. Replace any thermostatic releases that have been damaged. Replace any fixed temperature releases or pilot heads that have operated. To drain the hydraulic release piping (optional), pull the handle inside the emergency release.
6. Replace any sprinklers and/or spray nozzles that have been damaged or exposed to fire conditions.
7. Perform all maintenance procedures recommended in technical data describing individual components of the system that has operated.
8. Return the system to service as soon as possible. Refer to PLACING THE SYSTEM IN SERVICE.

## XX. TROUBLESHOOTING VIKING DELUGE SYSTEMS

### A. PORV

The Viking Model C-1 PORV is a field serviceable part that is made up of various components. This device is essentially a hydraulic latch which holds the valve open, even when using resettable detection devices.

#### **Problem:**

The PORV won't reset after the valve water supply is shut off and the system is drained.

#### **Remedy:**

1. There is water pressure still being applied to the sensing end of the PORV. Break the union in the sensing line to see where the water is coming from, and correct the problem. There should be no water pressure in the sensing line once the system is shut down and drained.
2. There are metal shavings, mud or silt caught under the clapper of the PORV. Remove the drain line from the discharge end of the PORV, then slightly open the priming line valve. With the eraser end of a pencil, push on the clapper and let some water flow out the discharge end of the PORV. This may wash the metal shavings, mud, etc, away from the underside of the clapper. If it does not clear the obstructions, then the PORV must be removed, disassembled, cleaned, reassembled and installed.
3. There is mud or silt, etc, inside the PORV at the sensing end, keeping pressure on the diaphragm and schrader core valve. This is very common where river water or non-potable water is being used. The PORV must be disassembled, cleaned, then reassembled.
4. The valve stem of the schrader core valve is bent, or the diaphragm at the sensing end is distorted. With the priming valve closed and the system still shut down, remove the six screws at the sensing end of the PORV, inspect the diaphragm for distortion, and check the schrader core valve to inspect the stem. If the diaphragm is distorted or the schrader core valve stem is bent, replace with new.
5. The hole through the diaphragm at the discharge end of the PORV is plugged. The PORV must be disassembled and the diaphragm checked for obstructions in the diaphragm hole, by bending the diaphragm back and fourth at the location of the hole. This will break loose any obstructions.

#### **Problem:**

The PORV doesn't operate when the valve trips, and it doesn't vent the priming chamber. (No water flows out of the ¼" drain after the valve trips.)



## TECHNICAL DATA

DELUGE SPRINKLER  
SYSTEM

The Viking Corporation, 210 N Industrial Park Drive, Hastings MI 49058

Telephone: 269-945-9501 Technical Services 877-384-5464 Fax: 269-818-1680 Email: techsvcs@vikingcorp.com

**Remedy:**

1. The diaphragm at the discharge end of the PORV is split, and is allowing water to enter the chamber behind the clapper faster than it can be vented through the schrader core valve. The PORV must be disassembled and the diaphragm checked for tears, etc.
2. The 1/4" drain from the schrader valve is plugged, and is not venting the water from the chamber behind the clapper. Check the 1/4" drain line to see if it is properly piped, and not obstructed. These outlets are occasionally plugged. Remove the plug and use 1/4" steel piping to run the drain to the drip cup.
3. The hole through the diaphragm at the discharge end of the PORV is plugged. The PORV must be disassembled and the diaphragm checked for obstructions in the diaphragm hole, by bending the diaphragm back and fourth at the location of the hole. This will break loose any obstructions.
4. Some drain piping installations from the 1/4" connection of the PORV were run in copper tubing instead of 1/4" steel pipe. Check the tubing for dings or bends because the tubing may be "pinched." If the 1/4" drain from the schrader valve is plugged or "pinched" off, the PORV will not function properly.

**B. Pneumatic Actuator**

The Viking Model H-1 and corrosion resistant Model R-1 Pneumatic Actuators are both spring loaded to open, rolling diaphragm, piston operated valves. They are used wherever a separation is required between the detection and operating systems. There is a factory drilled weep hole drilled into the spacer. The weep hole is there to identify either an air leak or water leak in the device.

**NOTE:** There are several Viking devices that look similar to the Viking Model H-1 Pneumatic Actuator, such as the PSOV and the antiflood device. DO NOT replace one device with a similar looking device. Always replace the device with an exact replacement part.

**Problem:**

There is air coming out of the weep hole in the pneumatic actuator.

**Remedy:**

The upper diaphragm is torn, scuffed, or cut, and is leaking air out through the diaphragm. With the system shut down, remove the air piping from the top of the pneumatic actuator. Unscrew the 3 #10 x 24 x 1 1/4" HHS from the cover, and remove the cover and the upper diaphragm. Inspect the device inside, and make sure there are no burrs, etc that could cut the diaphragm. Replace the diaphragm, and reassemble the device. Place the device back into the valve trim, and repressurize the system with air. Check for leaks, then return the system to service as described in the current applicable technical data pages.