



# uPVC Fittings

FOR DRAINAGE APPLICATIONS



التوزيع من قبل شركة المؤسسة الوطنية للتسويق المحدودة

Distributed by NATIONAL MARKETING EST. CO. LTD.

[www.namat.com](http://www.namat.com)



# Certifications



## CERTIFICATE OF REGISTRATION

This is to certify that the management system of:

**New Products Industries Co. Ltd. (NEPROPLAST)**

Main Site: PO Box: 460, Street No 53, Industrial City – Phase 3, Jeddah – 21411, Kingdom of Saudi Arabia  
 Additional Site: PO Box: 460, Plot No: 0150600005, Industrial Area 2, Jizan Road, Jeddah - 21422, Kingdom of Saudi Arabia

has been registered by Intertek as conforming to the requirements of:

**ISO 9001:2015**

The management system is applicable to:

Main Site: The Manufacture of UPVC (PVC) and CPVC Pipes  
 Additional Site 1: The Manufacture of HDPE Pipes, UPVC (PVC) & CPVC Fittings

Certificate Number: QMS 27050-04  
 Initial Certification Date: 20 September 2012  
 Date of Certification Decision: 29 July 2018  
 Issuing Date: 29 July 2018  
 Valid Until: 19 September 2021



**Calin Moldovean**  
 President, Business Assurance

Intertek Certification Limited, 10A Victory Park, Victory Road, Derby DE24 8ZF, United Kingdom

Intertek Certification Limited is a UKAS accredited body under schedule of accreditation no. 014



In the issuance of this certificate, Intertek assumes no liability to any party other than to the Client, and then only in accordance with the agreed upon Certification Agreement. The certificate's validity is subject to the organization maintaining their system in accordance with Intertek's requirements for system certification. Validity may be confirmed via email at [certificates.validation@intertek.com](mailto:certificates.validation@intertek.com) or by scanning the code to the right with a smartphone. The certificate remains the property of Intertek, to whom it must be returned upon request.

I ISO 9001:2015

II OHSAS 18001:2007



## CERTIFICATE OF REGISTRATION

This is to certify that the management system of:

**New Products Industries Co. Ltd. (NEPROPLAST)**

Main Site: PO Box: 460, Street No 53, Industrial City - Phase 3, Jeddah - 21411, Kingdom of Saudi Arabia  
 Additional Site: PO Box: 460, Plot No: 0150G00005, Industrial Area 2, Jizan Road, Jeddah - 21422, Kingdom of Saudi Arabia

has been registered by Intertek as conforming to the requirements of:

**OHSAS 18001:2007**

The management system is applicable to:

Site 1: The Manufacture of UPVC, CPVC Plastic Pipes  
 Site 2: The Manufacture of HDPE Plastic Pipes and UPVC, CPVC Fittings

Certificate Number: OHS 140522-03  
 Initial Certification Date: 19 January 2015  
 Date of Certification Decision: 18 April 2018  
 Issuing Date: 18 April 2018  
 Valid Until: 11 March 2021



**Calin Moldovean**  
 President, Business Assurance

Intertek Certification Limited, 10A Victory Park, Victory Road, Derby DE24 8ZF, United Kingdom

Intertek Certification Limited is a UKAS accredited body under schedule of accreditation no. 014



In the issuance of this certificate, Intertek assumes no liability to any party other than to the Client, and then only in accordance with the agreed upon Certification Agreement. The certificate's validity is subject to the organization maintaining their system in accordance with Intertek's requirements for system certification. Validity may be confirmed via email at [certificates.validation@intertek.com](mailto:certificates.validation@intertek.com) or by scanning the code to the right with a smartphone. The certificate remains the property of Intertek, to whom it must be returned upon request.

II

## Manufacturing Standards

ISO 4435 , ISO 3633 & ISO 1401-1 for non pressure drainage and soil / waste systems. Complies with saudi standards 1397,1398,1399 and 1400.

Neproplast - uPVC Fittings for soil, Waste and Vent are fully Compatible for use with uPVC pipe according to the following specifications :

- SSA 14 & 15 / 1998
- DIN 19534
- BS 4660,BS 5481
- PrEN R1452-1
- ISO R161/1
- DIN 8061 / 62
- EN 1401 - 1



**COLOUR** : Orange - Brown - RAL 8023

**RANGE** : 40MM - 315MM

**MARKING** : Neproplast PVC, OD OF PIPE,& Degree.

**JOINTING** : Rubber Sealed Socket joints with lip Seal Rings.  
rubber ring as per EN 681-2

### SOCKET DIMENSIONS:

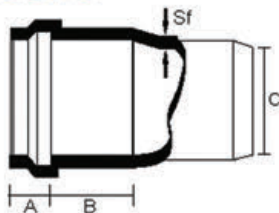

C	B	A	Sf min
40	29	16	3.2
50	31	16	3.2
75	38	17	3.2
110	51	21	3.2
160	56	29	4.7
200	60	34	5.9
250	Supplied on request		
315			
400			

### JOINTS TYPES:

Repair Coupling:

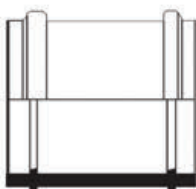

The main purpose of using Repair Coupling is to add and joint a new section of pipe or a piece of pipe with additional fittings

Register Coupling:



The main purpose of using Register Couplings joint to Fit the plain pipe by the push fit method, with equal insertion on each side.

# Fittings Design and Advantages

NEPROPLAST Fittings design will offer swept entry fillings with deep seal to reduce syphonage in the stack and loss of trap seals with smooth path for the outlet of sewage.

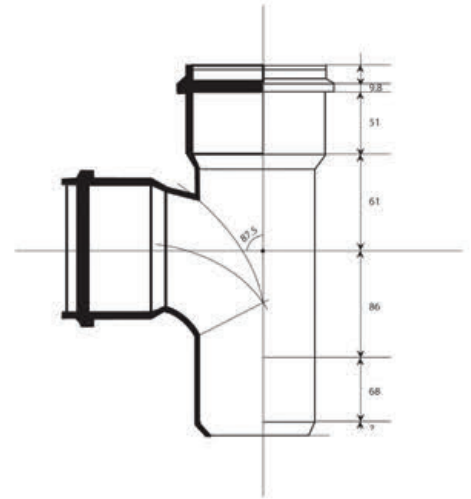

- A Product are manufactured to International Standard
- B ISO 9001 accredited Quality System
- C Testing to International Standards
- D Jointing and Installation advice and Services
- E Technical Services and Consultations
- F Timely Delivery

## ROUTINE QUALITY TEST

- The continuous contribution of our experienced and committed professionals is undoubtedly our key to achieve the highest quality products. The most advanced technological resources are used in maintaining a regular strict quality control program.
- NEPROPLAST labs are fully equipped with the most advance equipment to conduct both on-line quality control and laboratory tests meeting major international standard test.

Few of the test conducting on the fittings

- 1 Full Dimensional Check
- 2 Impact Test
- 3 Reversion Test
- 4 Methylene Chloride Test
- 5 Oven Test (ISO 580)
- 6 Leak Proof Test
- 7 Tensile / Elongation test
- 8 Various Other Tests to Maintain
- 9 Quality





## uPVC FITTINGS

### Material Properties

Properties	Values	Values	Standard
Density	• 1.42 - 1.43 g/cc	• 1.38 g/cm <sup>2</sup>	•
Tensile Strength	• 48.3 MPa	• 50-60 N / mm <sup>2</sup>	•
Impact Resistance	• 1.6 ft.lbs / in. of notch at 23 °C	• 4.75-5.42 joules	• DIN 53453 without Break
Modulus of elasticity	• 2900 MPa	• 3.00 N / mm <sup>2</sup>	•
Co-efficient of elongation	• 2.8 x 10 <sup>-5</sup> in / in / °F	• = 80 x 10 <sup>-6</sup> k	•
Thermal Conductivity	• 0.19 w/M.K	• = 0.15 W / mk	•
Water Absorption	• 0.05%	• < 4 mg / cm <sup>2</sup>	•
Surface Resistance	• < 10 <sup>-19</sup> ohm (Ω)	•	• DIN 53482
Elongation at break	• 90 min %	• 10-50%	•
Specific Heat	• 0.25 KCal / kg / °C	•	•
Vicat softening temperature	• 85 @ 1 kg load °C	•	•
Flexural Strength	• 950 Kg / cm <sup>2</sup>	•	•
Volume resistivity	• 10 <sup>14</sup> OHM / cm	•	•
Dielectric strength	• > 740 KS / mm	•	•
Flammability	• Will not support combustion	•	•

### Lubrication

Suitable joint lubricant should be used for joining socketed pipe and fittings as recommended by manufacturer NEPRO see Data Sheet on “last Page ”

### Lubricant consumption

Amount of Lubricants for each 100 joints



Diameter D/N	Pipe outside Dia mm	Kilogram Of Lubricant
DN 40	50	1.00
DN 65	75	1.00
DN 100	110	1.10
DN 150	160	1.80
DN 200	225	2.40
DN 250	280	3.15
DN 300	315	3.85



## Drainage Fittings With Locked-In Seals

NEPROPLAST Drainage Fittings come pre-fitted with Locked-In Lip Seals for premium leaktightness and performance for the lifetime of the fittings.

### Assembly Instructions



Seal already pre-fitted and locked-in

#### STEP 1

No attempt should be made to remove the seal; it is locked-in and can be damaged if removed.

#### STEP 2

- The spigot and socket of the pipe should be checked for damage prior to jointing.
- The pipe spigot should be chamfered with an angle of 15° taking care to remove all burrs.
- Both spigot and socket including the sealing ring should be free from dirt and other foreign matter.
- Lubricant should be applied to the spigot end of the pipe.





## uPVC FITTINGS

### STEP 3

- Immediately after lubrication, the spigot should be brought into contact with the socket.
- Both spigot and socket should correctly aligned and then slide the spigot into the socket, thus compressing the seal until the joint is fully made.

All components manufactured in ISO 9001 Quality Management System



### TESTING OF SEWERS & DRAINS:

Non pressure draining system can be tested by water test or air test.

## Water Test

Make sure all outlets are closed except the highest level. Allow for a water head of 1.2m using standard pipe. Fill the pipe with water and leave for few hours. Top up and record the water level. A drop of 50 mm is allowed in accordance with values shown in the table below



Table. 4

### DURATION OF WATER TEST (MINS) FOR 50 MM WATER DROP

2.5	5.0	7.5	10	15	20	25	40
-----	-----	-----	----	----	----	----	----

### MINIMUM LENGTH OF PIPE UNDER TEST (METER)

60	30	20	15	10	7.5	6.0	5
80	40	27	20	13	10.0	8	6.5
120	60	40	30	20	15.0	12	10.0
-	90	50	40	25	20.0	15	12.5
-	120	60	45	30	25.0	18	15
-	-	80	60	40	30.0	24	20
-	-	100	75	50	37.5	30	25

All the above figures are given in good faith and would not be part of any contract or any warranty  
Always chamfer cut pipe and lubricate all plain ended spigots for perfect push-fit



## Air Tightness Test

### Test Assembly

The test assembly shall consist of above apparatus including a precision pressure gauge or manometer.

A - a specimen of pipe mounted in two clamped blocks.

B - One end of the pipe is sealed with a plug that has a combined water and air inlet.

C - All fittings shall be sealed at all open ends with plugs,

D - one Fitting will have a water outlet and shut-off valve mounted centrally in the sealing plug.

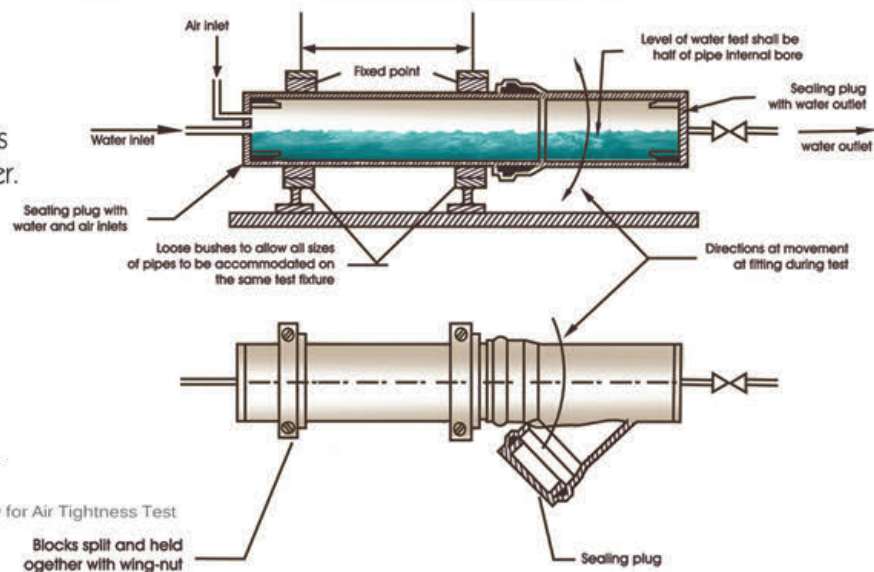

Figure C-1: Test Assembly for Air Tightness Test

### Procedure

- Apply a strong solution of soapy water or detergent around the angular space between the mouth of the fitting and the pipe .
- Open the water outlet valve and close the air inlet valve on the pipe shut-off
- Open the water inlet valve, when the assembly is half full, that is when water flows from the outlet, close the water inlet and outlet valves.
- Open the air inlet valve and increase the internal air pressure to 0.01 MPa(0.1 bar + 0.01 bar) at ambient temperature. Maintain this pressure for 5 min. during which, any leaks which occur between the mouth of the fitting and the pipe, and which are evident by the formation of bubbles should be noted.
- Deflect the pipe manually in the socket of the fitting until it reaches the maximum permissible deflection for the particular joint under test. Carry out this deflection at 0°, 90°, 180° and 270°(see figure C1 ) maintaining it for 1 min in each of these directions.

If bubbles appear at any time during the test , a new application of soapy water or detergent should be applied. If emission of bubbles continues during the test, the joint shall not be deemed to meet the requirements of the test.

The test requirements shall be fulfilled for all types of test assembly,including those combining minimum spigot ends and maximum sockets. The pressure shall be allowed to drop as specified in the table below.

Table. 5

Air test		Table
DIA. OF PIPE	AIR TEST U TUBE DUR. (MINS)	WATER DROP MAX (MM)
75	1.5	25.0
110	2.0	25.0
160	3.0	25.0
200	4.0	25.0
250	4.5	25.0
315	5.0	20.0
400	6.0	20.0





## uPVC FITTINGS

### HANDLING

- Take all reasonable care when handling uPVC Fittings, in very cold conditions as impact strength of the material is reduced.
- Do not throw or drop pipes.

### STORAGE

#### 1) Fittings

Fittings should be stored in their original packaging and staked in cartons or bags on shelves.

When storage in the open is required, then screening from the sun is necessary with an air gap between the stored fittings. In case fittings are removed from their boxes do not mix with other materials. Avoid storage of uPVC fittings near an open flame or extreme heat. Store fittings under cover. .

#### Storage in hot climates

- Ultra-violet light can affect fittings:  
fittings colour may change and rubber seals may be degraded.
- Accordingly:
  - A- store all materials in well-ventilated, shady conditions
  - B- Do NOT expose to direct sunlight
  - C- Keep fittings in original packaging until required for use

### INSTALLATION GUIDE

#### Trench Construction

It is essential to avoid high stress concentrations and sharp objects such as large stones or flints which should not come into contact with the surface of the pipe. The flexible nature of uPVC pipes helps them to accommodate deformations resulting from ground movement or from other differential settlement under normal circumstances.

#### 1) Trench Contour

The trench bottom should be continuous, relatively smooth and free of rocks. it is advisable to pad the trench bottom using sand or compacted fine-grained soil.

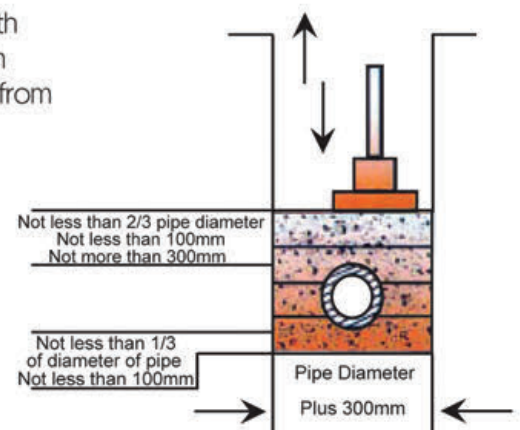



## 2) Trench Width

The recommended trench width should be at least equal to the Pipe & Fittings outside diameter plus 300 mm.

## 3) Trench Depth

The trench depth is the distance between the ground level and the upper level of the Pipe & Fittings. Trench depth  $1.5D$ , where  $D$  is the diameter of the Pipe & Fittings.

### Installation to Normal Vehicle Traffic

Trench depth

The minimum total cover should be not less than (ASTM F 690)

Requirements

- Size 32 to 63 mm in diameter - 450 mm
- Size 75 to 110 mm in diameter - 600 mm
- Size 140 to 400 mm in diameter - 750 mm
- Size above 400 mm in diameter - 900 mm

### Ground Features and laying Tips

The lateral reaction of the ground caused by the deformation of the Pipe & Fittings, depends on the soil and laying methods and on the level of tamping needed for back filling material

### External Loads on a Buried Pipe & Fittings.

External Loads on a Buried Pipe

- Where EL : Earth load  
 TL : Traffic load  
 HL : Hydrostatic load

### Calculations for loads on a buried Pipe & Fittings

1) Earth load  $EL = F.H \text{ kg/m}^2$

- Where  $F$  = porter density of sand  
 $H$  = depth of the trench

2) Traffic load  $TL = 3/2 \times P/(h+d/2)^2 \Psi \text{ kg/m}^2$

- Where  $\Psi$  = dynamic factor for vehicle =  $1 + 0.3 H$   
 $P$  = concentrated load of the passing vehicle

- Normally,  $P$  = 3000 kg for yard motor vehicle  
 $P$  = 6000 kg for light motor vehicle  
 $P$  = 9000 kg for heavy motor vehicle

### 3) Hydrostatic load

(The load due to the presence of the aquifer)HL

$HL = a. (H - H1 + D/2) \text{ kg/m}^2$

$a$  = specific weight of the water ( $\text{kg/m}^3$ )

$H$  = the distance between the plane of site and the level of the aquifer.

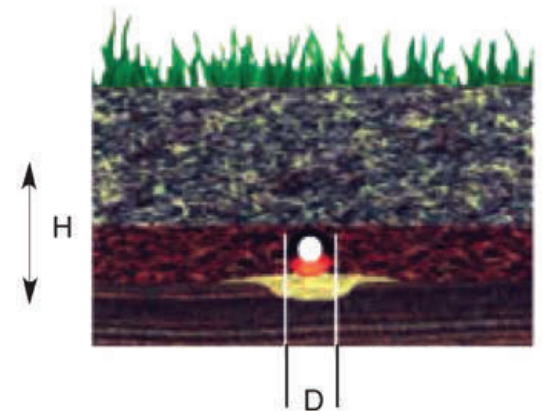
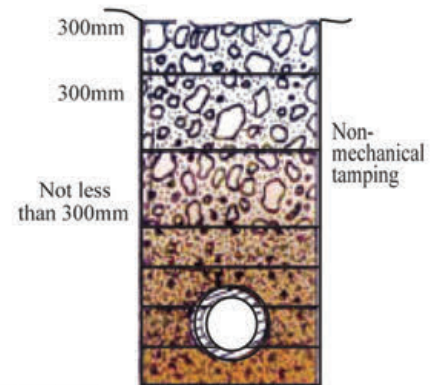

Figure "1"

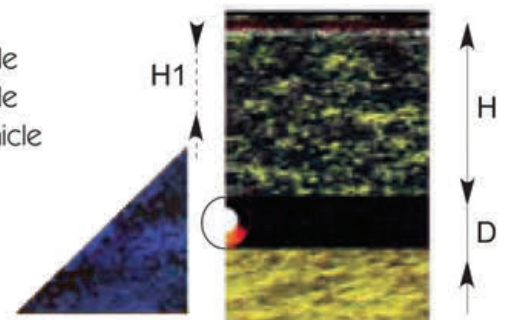
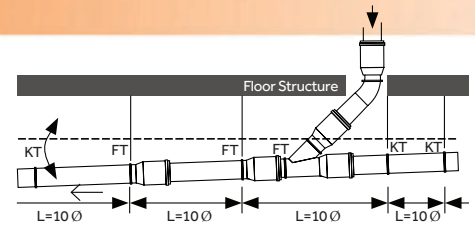

Figure "2"

## VERTICAL INSTALLATION

In horizontal installation, pipe clamps should be placed at intervals which are approximately ten times bigger than the pipe diameter. This will ensure that the installation is fixed and will not bend.



## ADVANTAGES OF MECHANICAL PIPING SYSTEM USING LOCKED-IN SEALS

Neproplast locked-in seals fittings offer mechanical fixing joints which have substantial advantages. Moreover, the revolution by the polymer industry had played a vital role in the reduction of water and sewage networks costs. These advantages could be summarized as follows:

- **Corrosion Resistance**  
uPVC fittings being non-conductor and non-metallic, it resist all types of galvanic and electro-mechanically influences, all types of corrosion caused by water, industrial liquids and chemicals. Thus increasing the lifetime of installed uPVC piping system.
- **Resistance to biological attack and growth**  
uPVC fittings is resistant to any microscopic life that it might be exposed to. It does not offer an nourishment source to any bacterial life form and is completely guaranteed to withstand any such growth.
- **Resistance to abrasion**  
uPVC pipes are highly resistant to abrasion due to stress from abrasion fluids of excessive pressure. Tests have shown that uPVC Piping System are up to 2.5 times more resistant to abrasion when compared to steel.
- **Reaction with building materials**  
uPVC does not react with any of the normal building materials like cements and paints. However, information about chemical resistance of uPVC Fittings to a wide range of chemicals can be found in the tables of chemicals resistance list. Please consult with supplies manufacturer.
- **Flammability**  
uPVC fittings is self extinguishing material as per BS2782 and does not support fire and toxic fumes.
- **Effect of sunlight**  
Long exposure to direct sunlight caused the color of uPVC fittings to fade, in addition to the reduction of impact strength. The effect of sunlight does not seriously affect the performance of the system, however it is always advisable to protect the system from the direct exposure to sunlight.
- **Effect to frost**  
The uPVC fittings is not affected by frost, however sub-zero temperature reduce the impact strength of the uPVC system. Therefore, extra care is to be given while handling and installing uPVC during sub-zero temperatures.

## ADVANTAGES OF DRAINAGE FITTINGS WITH LOCKED-IN SEALS

Locked -in seals bring significant advantages to both the installer and the customer. Available in all sizes 50mm to 200 mm.

### SEAL, FITTING AND PIPE ALL WORK TOGETHER

- Seals comply with EN 681-2
- Fittings comply with EN 1401 / SASO 1397 / SASO 1399 / ISO 3633 / ISO 4435
- Pipes comply with EN 1401 / EN 1329 / SASO 1209 / SASO 1395
- Seals which comply with EN 681-1 and EN 681-2 and which are for using the Drainage, Sewage and Waste application are designed for continuous use up to 45°C and intermittent use at temperatures up to 95°C.
- Seals are pre-fitted into the fitting, snugly filling the seal groove, preventing the ingress of dirt.
- Seals are locked-in to the seal groove by the PP retaining ring part of the seal, so that it cannot fall out of place and is almost impossible to be dislodged during installation, whereas ordinary lip seals can easily fall out or become dislodged.
- Assembly forces are very low compared to standard lip seals making them easier to assemble and push together.
- Minimum risks of leakage due to site problems as it is so easy to clean and assemble.
- They are suitable for use in both underground and indoor application areas for drainage, sewage and waste applications.
- Neproplast fittings with locked-in seals meet all the performance requirements of relevant standards including the 1500 cycle hot / cold cycling test.
- Best leak tightness performance when tested in accordance with EN 1277 when compared to standard lip seals.
- Pipes are normally jointed and put into use in a straight condition, but pipe systems using Neproplast pipes and fittings with locked-in seals can then be deflected up to 1° and can also accommodate up to 2° angular deflection without leakage if subjected to any inconsistent settlement of backfill.
- No leakage if pipe is crushed even up to 10% change in diameter.
- Performance of Neproplast fittings with locked-in seals is much better than standard lip seals in these leakage tests. Many ordinary lip seals types are unable to achieve these standard in angular deflection and crush situations.



## REPAIR COUPLING

Table.2

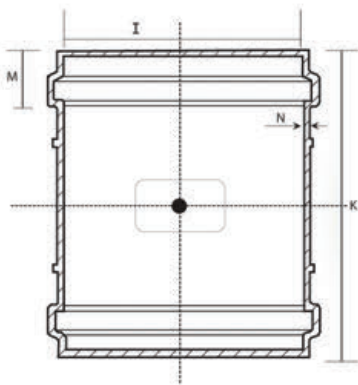

ORDERING CODE	SIZE mm l mm	Weight in kg	DIMENSION		WALL THICKNESS N mm
			K mm		
SND 03 00.10*	40	0.122	111		3.2
SND 03 00.20	50	0.122	117		3.2
SND 03 00.30	75	0.203	131		3.2
SND 03 00.40	110	0.344	157		3.4
SND 03 00.50	160	0.921	200		4.7
SND 03 00.60	200	1.442	216		4.1
SND 03 00.70*	250	1.940	252		5.5
SND 03 00.80*	315	3.406	293		6.9

## REGISTER COUPLING

Table.3

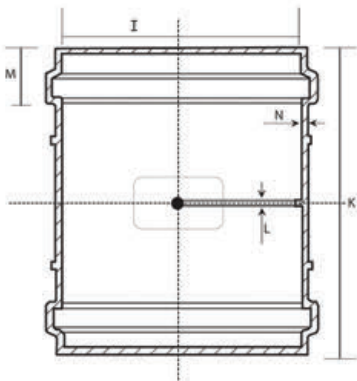

ORDERING CODE	SIZE mm l mm	Weight in kg	DIMENSION		WALL THICKNESS mn N mm
			K mm	L mm	
SND 02.00.10*	40	0	111	3	3.2
SND 02.00.20	50	0.120	117	3	3.2
SND 02.00.30	75	0.201	131	3	3.2
SND 02.00.40	110	0.339	157	3	3.4
SND 02.00.50	160	0.915	200	4	4.7
SND 02.00.60	200	1.405	216	2	4.1
SND 02.00.70*	250	1.899	252	2	5.5
SND 02.00.80*	315	3.421	293	2	6.9

# uPVC FITTINGS



## BEND 15

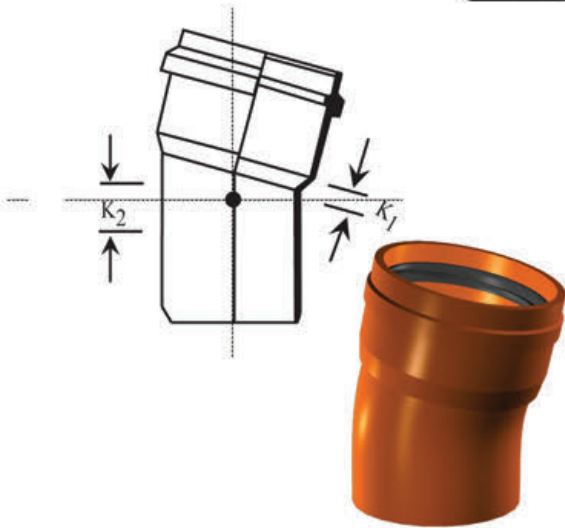
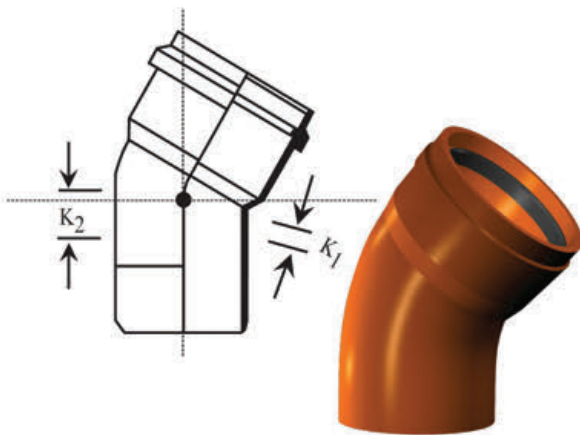

Table. 4

ORDERING CODE	SIZE mm	Weight in kg	DIMENSION		WALL THICKNESS mm
			K1 mm	K2 mm	
SND 04.15.20*	50	0	6	9	3.2
SND 04.15.30*	75	0	6	11	3.2
SND 04.15.40*	110	0.219	12	19	3.2
SND 04.15.50*	160	0.539	13	19	3.2
SND 04.15.60*	200	0.950	15	23	4.1
SND 04.15.70*	250	1.960	19	30	5.5
SND 04.15.80*	315	3.684	23	38	6.9

## BEND 30

Table. 5



ORDERING CODE	SIZE mm	Weight in kg	DIMENSION		WALL THICKNESS mm
			K1 mm	K2 mm	
SND 04.30.20*	50	0	10	12	3.0
SND 04.30.30*	75	0	11	15	3.0
SND 04.30.40*	110	0.236	17	21	3.0
SND 04.30.50*	160	0.647	24	30	3.6
SND 04.30.60*	200	1.155	30	38	4.5
SND 04.30.70*	250	2.332	37	49	6.1
SND 04.30.80*	315	4.160	47	61	7.7



## BEND 45

Table. 6

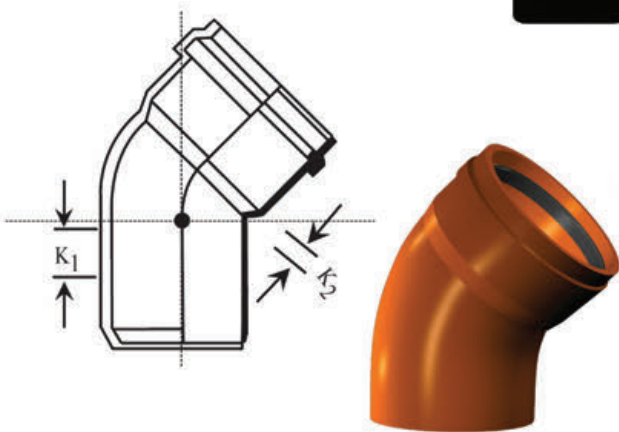

ORDERING CODE	SIZE mm	Weight in kg	DIMENSION		WALL THICKNESS mm
			K1 mm	K2mm	
SND 04.45.10*	40	0	15	21	3.2
SND 04.45.20	50	0.122	12	16	3.2
SND 04.45.30	75	0.215	23	29	3.2
SND 04.45.40	110	0.394	25	29	3.2
SND 04.45.50	160	1.090	38	42	4.7
SND 04.45.60	200	2.231	46	54	4.5
SND 04.45.70*	250	2.513	57	69	6.1
SND 04.45.80*	315	4.660	72	86	7.7

## BEND 87 1/2

Table. 7

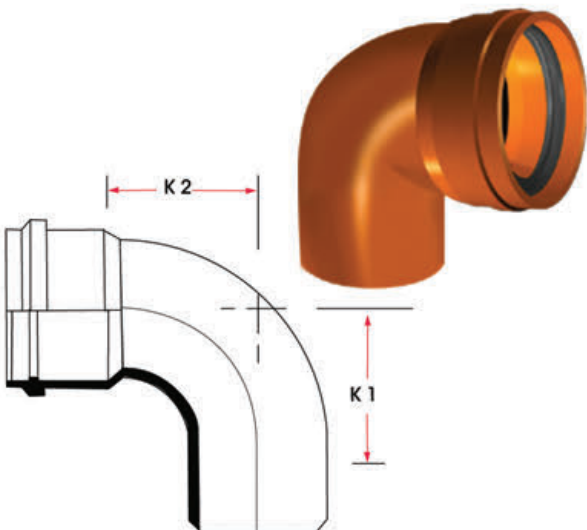

ORDERING CODE	SIZE mm	Weight in kg	DIMENSION		WALL THICKNESS mm
			K1 mm	K2 mm	
SND 04.87.10*	40	0	37	39	3.2
SND 04.87.20	50	0.149	38	40	3.2
SND 04.87.30	75	0.278	58	65	3.2
SND 04.87.40	110	0.529	86	86	3.2
SND 04.87.50	160	1.670	132	110	4.7
SND 04.87.60	200	2.675	129	113	4.5
SND 04.87.70*	250	3.467	145	143	6.1
SND 04.87.80*	315	6.272	166	180	7.7



## uPVC FITTINGS

Table. 8

### BRANCH 45

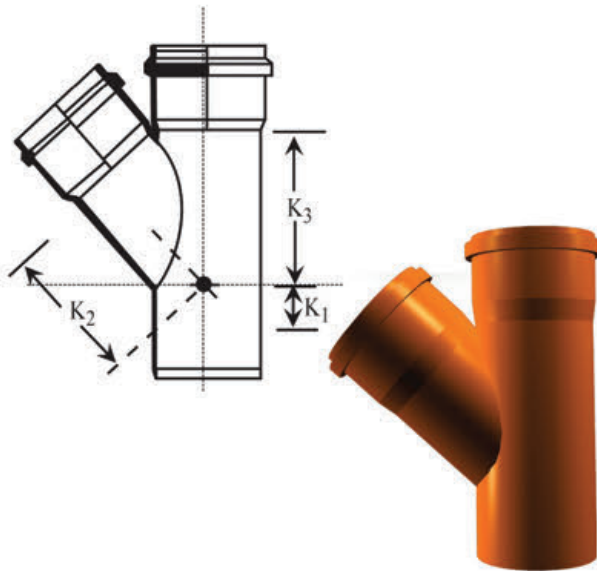

ORDERING CODE	SIZE mm	WEIGHT in kg	DIMENSION			Wall Thickness mm
			K1 mm	K2 mm	K3 mm	
SND 05.45.11*	40X40	0	10	49	49	3.2
SND 05.45.22	50X50	0.223	14	62	62	3.2
SND 05.45.33	75X75	0.411	23	95	95	3.2
SND 05.45.42	110X50	0.507	4	120	112	3.2
SND 05.45.43	110X75	0.614	0	107	95	3.2
SND 05.45.44	110X110	0.819	25	136	136	3.2
SND 05.45.55	160X160	2.180	37	19	194	4.7
SND 05.45.54	160X110	1.604	2	168	159	4.7
SND 05.45.66	200X200	2.792	46	241	241	5.9
SND 05.45.65	200X160	3.557	19	221	214	5.9
SND 05.45.64	200X110	1.680	-16	195	180	6.1
SND 05.45.77*	250X250	5.520	57	301	301	6.1
SND 05.45.76*	250X200	4.361	24	274	268	6.1
SND 05.45.75*	250X160	3.560	-3	254	241	6.1
SND 05.45.74*	250X110	3.490	-37	228	206	6.1
SND 05.45.88*	315X315	0	72	378	378	7.7
SND 05.45.87*	315X250	8.620	28	344	335	7.7
SND 05.45.86*	315X200	7.027	-5	318	302	7.7
SND 05.45.85*	315X160	5.820	-32	297	275	7.7
SND 05.45.84*	315X110	0	-66	272	240	7.7

### BRANCH 87 1/2

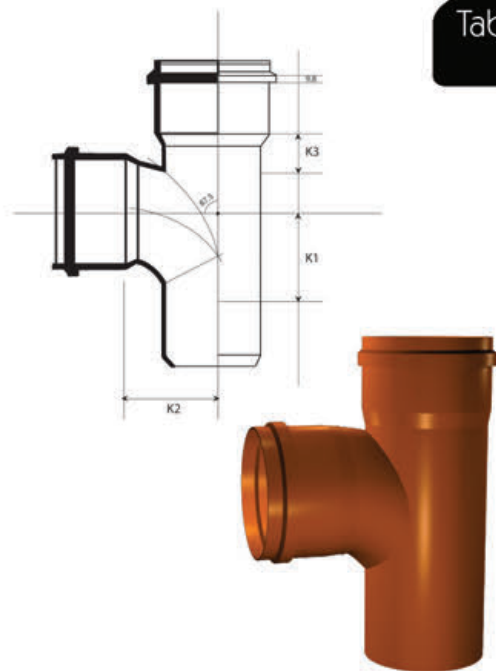

Table. 9

ORDERING CODE	SIZE mm	Weight in kg	DIMENSION			WALL THICKNESS mm
			K1 mm	K2 mm	K3 mm	
SND 05.87.11*	40X40	0	37	39	25	3.2
SND 05.87.22	50X50	0.216	46	50	31	3.2
SND 05.87.33	75X75	0.388	62	67	44	3.2
SND 05.87.44	110X110	0.746	83	87	62	3.2
SND 05.87.43	110X75	0	52	80	45	3.2
SND 05.87.42	110X50	0	28	60	32	3.2
SND 05.87.55	160X160	1.952	80	93	93	4.7
SND 05.87.54	160X110	1.201	60	87	65	4.7
SND 05.87.66	200X200	2.132	105	111	111	5.9
SND 05.87.65	200X160	1.915	86	108	91	5.9
SND 05.87.64	200X110	1.766	61	106	67	6.1
SND 05.87.77*	250X250	4.333	90	132	100	6.1
SND 05.87.76*	250X200	4.131	90	134	100	6.1
SND 05.87.75*	250X160	3.633	132	136	143	6.1
SND 05.87.74*	250X110	3.504	132	143	143	6.1
SND 05.87.88*	315X315	8.448	166	178	178	7.7
SND 05.87.87*	315X250	0	166	174	178	7.7
SND 05.87.86*	315X200	5.813	166	170	178	7.7
SND 05.87.85*	315X160	3.382	93	164	104	7.7
SND 05.87.84*	315X110	6.136	93	162	104	7.7



## SOCKET PLUG

Table. 10

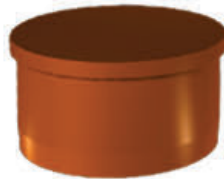
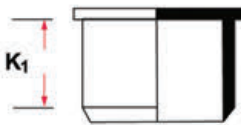

ORDERING CODE	SIZE mm	Weight in kg	DIMENSION		WALL THICKNESS mm
			K mm		
SND 11.00.10*	40	0	43		2.0
SND 11.00.20	50	0	45		2.0
SND 11.00.30	75	0	59		3.0
SND 11.00.40	110	0.161	41		3.0
SND 11.00.50	160	0.253	53		3.6
SND 11.00.60	200	0.935	64		4.5
SND 11.00.70*	250	1.147	95		6.1
SND 11.00.80*	315	2.014	100		7.7

## LEVEL INVERT REDUCER

Table. 11

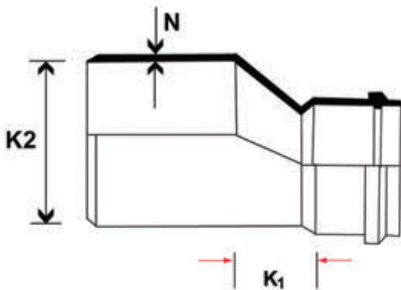

ORDERING CODE	SIZE mm	weight in kg	DIMENSION		WALL THICKNESS mm
			K1 mm	K2 mm	
SND 09.00.21*	50X40	0	21	50	2.0
SND 09.00.32	75X50	0.155	45	75	3.2
SND 09.00.42	110X50	0.265	50	110	3.2
SND 09.00.43	110X75	0.277	35	110	3.2
SND 09.00.54	160X110	0.657	34	160	3.6
SND 09.00.65	200X160	1.240	29	200	4.5
SND 09.00.76*	250X200	1.671	36	250	6.1
SND 09.00.87*	315X250	2.987	48	315	7.7





## uPVC FITTINGS

### ACCESS PIPE

Table. 12

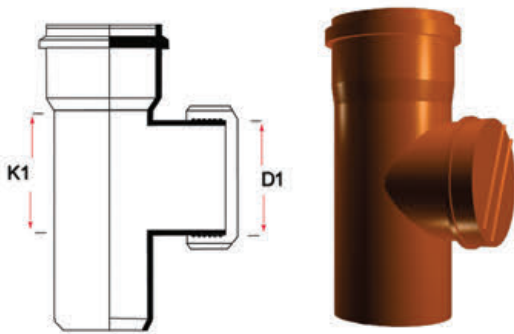

ORDERING CODE	SIZE mm	Weight in kg	DIMENSION		WALL THICKNESS mm
			K1 mm	D1mm	
SND 12.90.40*	110	0.553	137	96	3.2
SND 12.90.50*	160	1.182	251	114	4.7

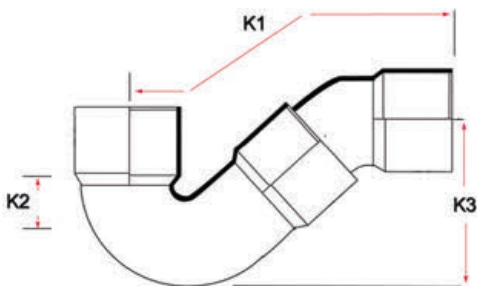

Table. 13

### P - TRAP



ORDERING CODE	SIZE mm		Weight in kg	DIMENSION			
	INLET	OUTLET		L mm	K1 mm	K2 mm	K3 mm
SND 13.00.44*	110	110	0	150	206	127	153
SND 13.00.50*	110	110	0	150	206	127	153



## ACCESS Plug and Cap

Table. 14

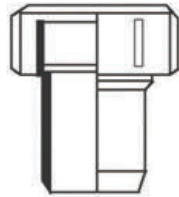

ORDERING CODE	SIZE mm	Weight in kg	DIMENSION		WALL THICKNESS mm
			K mm		
SND 12.00.10*	40	0	72		3.2
SND 12.00.20	50	0	72		3.2
SND 12.00.30	75	0	80		3.2
SND 12.00.40	110	0.289	125		3.2
SND 12.00.50*	160	0.345	138		4.7

## Floor Gully

Table. 15

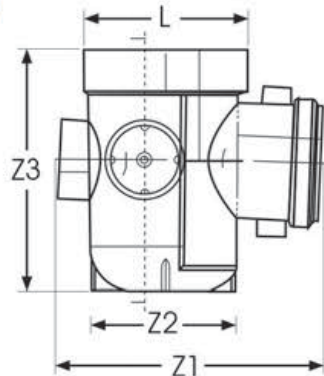

ORDERING CODE	SIZE mm		Weight in kg	DIMENSION			
	INLET	OUTLET		L mm	Z <sub>1</sub> mm	Z <sub>2</sub> mm	Z <sub>3</sub> mm
SND L30.00.30	75	50	0.52	117.5	187	105	172



## uPVC FITTINGS

### Pressure Equivalents

Atmosphere (atm)	Bar	Centimeters Of mercury	Feet head Of water	Inches head of mercury	Kilograms Per sq cm	Pounds Per sq inch	Meters head Of water
1.000	1.013	76.000	33.899	29.921	1.033	14.696	10.332
0.986	1.000	75.006	33.455	29.530	1.019	14.696	10.332
0.013	0.013	01.000	00.446	00.393	0.013	00.193	00.135
0.029	0.298	02.242	01.000	00.882	0.030	00.433	00.304
0.033	0.038	02.540	01.132	01.000	0.034	00.491	00.345
0.967	0.980	73.556	32.880	28.959	1.000	14.223	10.000
0.068	0.068	05.171	02.306	02.036	0.070	01.000	00.703
0.096	0.098	07.355	03.280	02.895	0.100	01.422	01.000

The Manning equation based on the condition of steady flow and open channel flow. The Manning n factor, like the Hazen Williams C factor, is an empirical number that defines the interior wall smoothness of a pipe.

The most common procedure for calculating open channel or partially full pipe flow conditions is to use the Manning Formula below:

$$V = \frac{(1.49) R^{0.67} S^{0.5}}{n}$$

Where: V = the average velocity at a cross section ft/sec

R = the hydraulic radius, ft

S = slope, ft/ft

n = the coefficient of roughness

Average Values of the Manning Roughness Factor

Material	Manning n
Plastic (PVC )	.009
Concrete	.013
Cast iron	.015

The "n" factor varies both with the degree of roughness of the inside of the pipe, and the flow velocity. Higher flow velocities tend to reduce the "n" factor in sewers as solids deposition and slime build-up on the bottom of the pipe is reduced.

Designing with PVC sewer pipe, an "n" factor of 0.009 is recommended.

scientific studies, many of which were carried out on "in service" pipes that had been operating for many years. The "n" values in these studies were found to range between 0.007 and 0.011. No published study has ever found an "n" value as high as 0.013 for a PVC system in any sewer operation even at minimum velocities of 2 ft/s (0.6 m/s). Please contact us if you wish to review the results of these studies.

The relatively low "n" values associated with PVC pipe are a result of various factors:

- Smooth, nonporous inside surface of the pipe
- Longer laying lengths (i.e. fewer joints)
- Lower profile gap at the joints
- Chemical and abrasion resistance of the material

By designing PVC sewer systems with the scientifically appropriate Manning value of 0.009, sewers can be installed at tighter grades, thus reducing excavation costs and disturbance. In some cases, it may even be possible to downsize the pipe while maintaining a particular flow capacity.



**EASY CLIP**

## EASY CLIP

- WATERTIGHT AND EASY-TO-INSTALL CONNECTION
- ADD-ON JUNCTION FULLY FIT-FOR-PURPOSE
- EXCELLENT MECHANICAL STRENGTH
- GREAT PROFIT-EARNER FOR STOCKIEST



Easy Clip mechanical saddles connect smooth plastic sewer pipes (PVC, PP, PE) to mains made from reinforced concrete, concrete, plastic (smooth and corrugated) as well as clay\* and GRP\*.

EASY CLIP SADDLES FIT SEWER MAINS FROM DN300MM UP TO DN1000MM WITH WALL THICKNESS UP TO 100MM  
INLET 160MM (INC. SWIVEL) AND 200MM (DIMENSIONS IN CHARTS)

## INSTALLATION



1 USING A SUITABLE HOLE SAW, DRILL A CHECK THE PIPE WALL THICKNESS (S). HOLE OF  $\varnothing 200 \text{ mm } 0/+3 \text{ mm}$  - ENSURE SAW CUT IS SQUARE TO THE PIPE TO AVOID AN OVAL CUT WHICH MAY RESULT IN LEAKAGE OF THE CLIP.



2 REMOVE SWarf AND CLEAN THE EDGES OF THE HOLE (SOFT ABRASION). INACCURATE DRILLING MAY AFFECT THE TIGHTNESS OF THE CLIP.



3 CHECK THE PIPE WALL THICKNESS (S).



4 REGISTER THE NUT: PIPE WALL THICKNESS (S) + 3 ÷ 4 CM.



5 INSERT EASY CLIP INTO THE HOLE MAKING SURE THE INNER EXPANSION GASKET IS CENTERED.



6 PUSH GENTLY AND VERTICALLY SO THE SADDLE FLANGE SITS PERFECTLY ONTO THE PIPE SURFACE.



7 USING THE KEY PROVIDED, SCREW THE NUT FULLY HOME ENSURING THE INNER EXPANSION GASKET IS COMPRESSED.



# ACCESSORIES

**EASY CLIP**

## Reinforced concrete and concrete ID

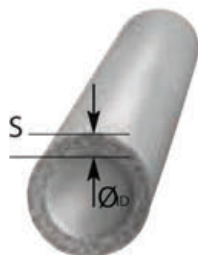

Pipe $\varnothing_{ID}$	300	400	500	600	700÷800
Easy Clip $\varnothing 160$ with swivel	1C16058	1E16058	1H16058	1H16058	1K16058
Easy Clip $\varnothing 200$	1C20058	1E20058	1H20058	1H20058	1K20058
S (mm)	40÷80	30÷80	40÷100	40÷100	50÷100

## Twin wall/corrugated plastic pipes ID

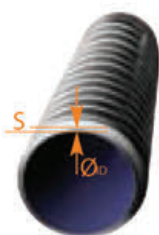

Pipe $\varnothing_{ID}$	300	400	500	600	700÷800
Easy Clip $\varnothing 160$ with swivel	1A16058	1E16058	1G16058	1H16058	1K16058
Easy Clip $\varnothing 200$	1A20058	1E20058	1G20058	1H20058	1K20058
S (mm)	30 max	30÷80	50 max	40÷100	100 max

## Twin wall/corrugated plastic pipes OD

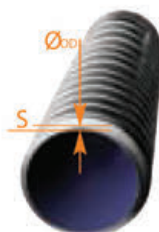

Pipe $\varnothing_{OD}$	315	400	500÷630	800÷1000
Easy Clip $\varnothing 160$ with swivel	1A16058	1D16058	1G16058	1K16058
Easy Clip $\varnothing 200$	1A20058	1D20058	1G20058	1K20058
S (mm)	30 max	35 max	50 max	100 max

## Plain wall/multilayer smooth plastic pipes OD

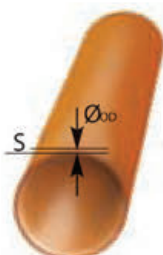

Pipe $\varnothing_{OD}$	315	400	500÷630	710
Easy Clip $\varnothing 160$ with swivel	1A16058	1D16058	1F16058	1J16058
Easy Clip $\varnothing 200$	1A20058	1D20058	1F20058	1J20058
S (mm)	5÷30	6÷35	9÷50	12÷50

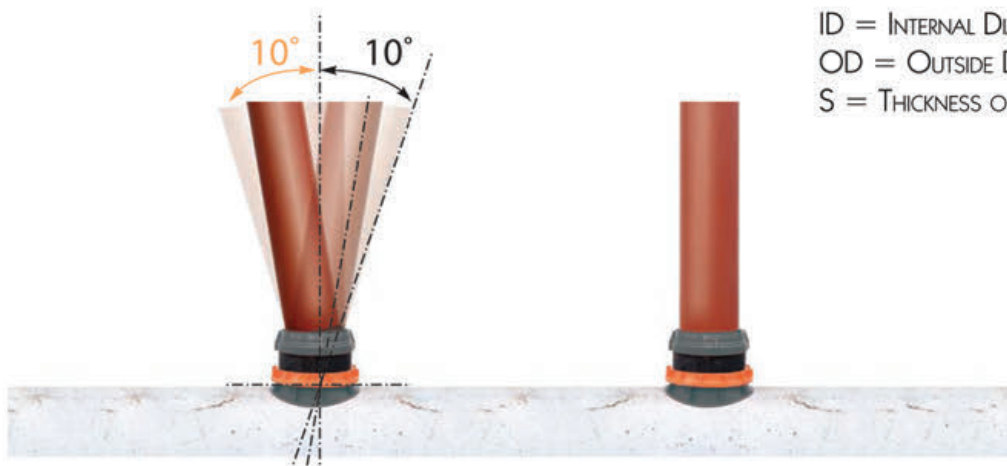

ID = INTERNAL DIAMETER OF THE PIPE  
 OD = OUTSIDE DIAMETER OF THE PIPE  
 S = THICKNESS OF THE PIPE



A SOLUTION TO FLOODING PROBLEMS

## FUNCTIONALITY

Climatic changes plus more and more concentrated urbanization often leads to having overloaded sewage networks with consequent flooding problems. The easiest and most economic solution to avoid this problem is the installation of a Non Return Valve. This will protect homes from costly damage, whose resolution are always the owners responsibility.

OTTIMA has to be installed on waste water pipes and allows the outflow to reach the municipal sewage network avoiding water backflows

It is highly recommended in cases of:

1. Fields which are under the water level
2. Areas closest to rivers, lakes, sea
3. When the sewage is linked to rainwater pipes (dangerous in case of heavy rain)
4. If a sewage network overload has already occurred
5. If an extension of the sewage network (with consequent overload) is probable
6. When the municipal sewage network includes pumping stations.



NORMAL WORKING SITUATION



EFFECTIVE ANTI-FLOODING

## AVAILABLE

Type 1



Type 2



## INSTALLATION EXAMPLES

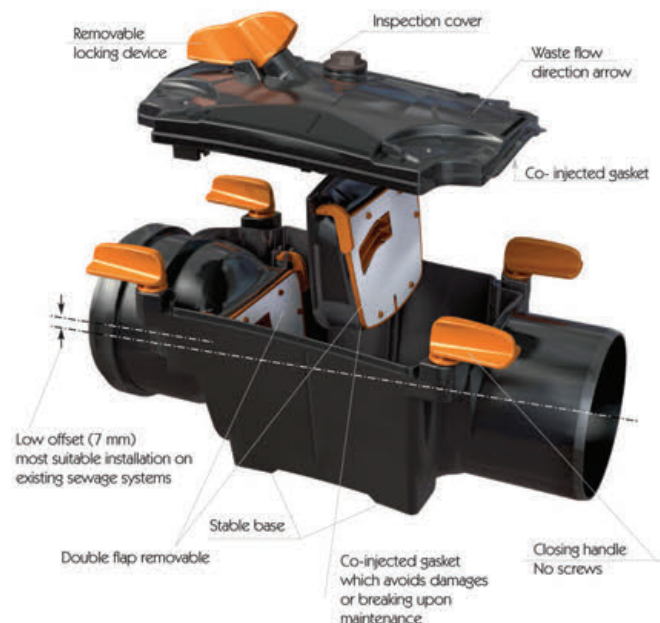



Manufacturing Plant

### New Products Industries Co. Ltd.

Manufacturing Plant, Jeddah

P. O. Box 460, Jeddah 21411. Kingdom of Saudi Arabia.

**Tel.** : +966 12 636 3558 / 1596 / 1205

**Fax** : +966 12 636 2364

**Email** : info@neproplast.com



شركة المؤسسة الوطنية للتسويق المحدودة  
NATIONAL MARKETING EST. CO. LTD.

Distributor

#### JEDDAH

P. O. Box 16375, Jeddah 21464. Kingdom of Saudi Arabia.

**Tel.** : +966 12 227 3271

**Fax** : +966 12 227 1796

**Email** : nm.jeddah@ikkgroup.com

#### RIYADH

P. O. Box 2729, Riyadh 11461. Kingdom of Saudi Arabia.

**Tel.** : +966 11 478 0015

**Fax** : +966 11 478 2567

**Email** : nm.riyadh@ikkgroup.com

#### DAMMAM

P. O. Box 2145, Al Khobar 31952. Kingdom of Saudi Arabia.

**Tel.** : +966 13 847 1315

**Fax** : +966 13 847 1312

**Email** : namat.dammam@ikkgroup.com

#### EXPORT

P. O. Box 16375, Jeddah 21464. Kingdom of Saudi Arabia.

**Tel.** : +966 12 647 5010

**Fax** : +966 12 647 4204

**Email** : allaudin.shaban@ikkgroup.com / export@ikkgroup.com

**Customer Service**

**+966 9200 18858**

**www.namat.com**



# قطع يو بي في سي

لتطبيقات الصرف

