

# 4"x2 WAY BREECHING INLET

## PRODUCT DESCRIPTION

NAFFCO breaching inlets are suitable for installation on dry risers only, in a building for fire fighting purposes, fitted with inlet connection at fire brigade access level and outlet connection at specified points, which is normally dry but capable of being charged with water by pumping from fire service appliances.

The breaching inlets are manufactured to comply with BS 5041 PART-3:1975 standard comprising of male instantaneous connections complying with BS 336:2010, drain valves complying with BS 5154, PN16 rated and non return valves.

The breaching inlets and its fittings are suitable for a normal working pressure of 10 bar.

## FEATURES

- BSI Kitemark and LPCB certified.
- Body material made of spheroidal graphite cast iron (Ductile Iron) to BS 1563:2011.
- Inlet connection and non-return valves material made of copper alloy to BS 12163:2011.
- Each inlet connections are fitted with non-return valve and are of spring loaded mushroom type.
- Each breaching inlet are painted RED internally and externally.



## SPECIFICATIONS

Model Number	NDR 095
Inlet Connection	2 Nos. Male Instantaneous Connector Complying to BS 336
Pressure Rating	Normal Working Pressure of 10 Bar
Nominal Size	100 mm Flanged Outlet
Test Pressure	20 Bar
Flange Drilling	BS 4504 Part: 2:1974 Table: 16/21

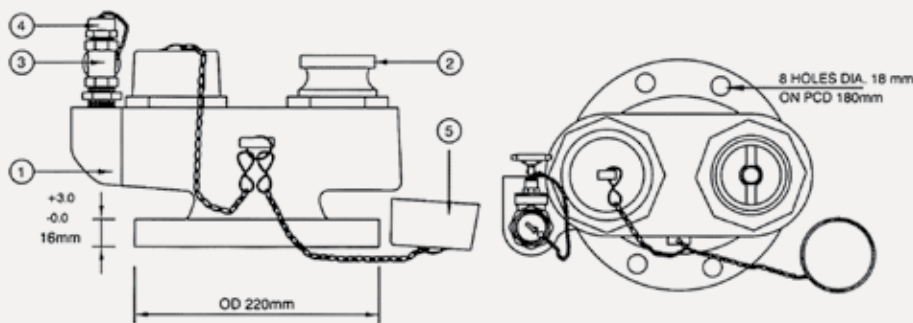

## BILL OF MATERIAL

Sl.No.	Description	Material
1	Body	Spheroidal Graphite Cast Iron to BS EN 1563:2011
2	Inlet Connection & Non-Return Valves	Copper Alloy to BS EN 12163:2011
3	Drain Valve	Copper Alloy to BS EN 12163:2011
4	Blank Cap for Drain Valve	Copper Alloy to BS EN 12163:2011
5	Blank Cap for Inlet Connector	Plastic

# 6"x4 WAY BREECHING INLET

## PRODUCT DESCRIPTION

NAFFCO breaching inlets are suitable for installation on dry risers only, in a building for fire fighting purposes, fitted with inlet connection at fire brigade access level and outlet connection at specified points, which is normally dry but capable of being charged with water by pumping from fire service appliances.

The breaching inlets are manufactured to comply to BS 5041 PART-3:1975 standard comprising of male instantaneous connections complying with BS 336:2010, drain valves complying with BS 5154, PN16 rated and non-return valves.

The breaching inlets and its fittings are suitable for a normal working pressure of 10 bar.

## FEATURES

- BSI Kitemark & LPCB certified.
- Body material made of spheroidal graphite cast iron (Ductile Iron) to BS 1563:2011.
- Inlet connection and non-return valves material made of copper alloy to BS 12163:2011.



- Each inlet connection is fitted with non-return valve and of spring loaded mushroom type.
- Each breaching inlet is painted RED internally and externally.

## SPECIFICATIONS

Model Number	NWR 115 & NWRX 115
Inlet Connection	4 Nos. Male Instantaneous Connector Complying to BS 336
Pressure Rating	Normal Working Pressure of 10 Bar
Nominal Size	150 mm Ranged Outlet
Test Pressure	20 Bar
Flange Drilling	BS 4504 Part : 2 : 1974 Table : 16/21

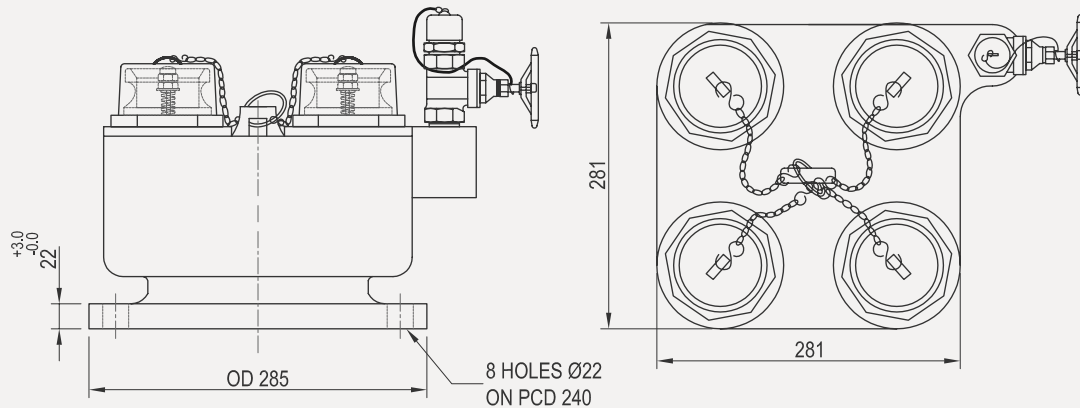

## BILL OF MATERIAL

Sl.No.	Description	Material
1	Body	Spheroidal Graphite Cast Iron to BS EN 1563:2011
2	Inlet Connection & Non-Return Valves	Copper Alloy to BS EN 12163:2011
3	Drain Valve	Copper Alloy to BS EN 12163: 2011
4	Blank Cap for Drain Valve	Copper Alloy to BS EN 12163: 2011
5	Blank Cap for Inlet Connector	Plastic