

4 FIRE ALARM CHECK VALVE DETAIL
G-PP002 N.T.S.

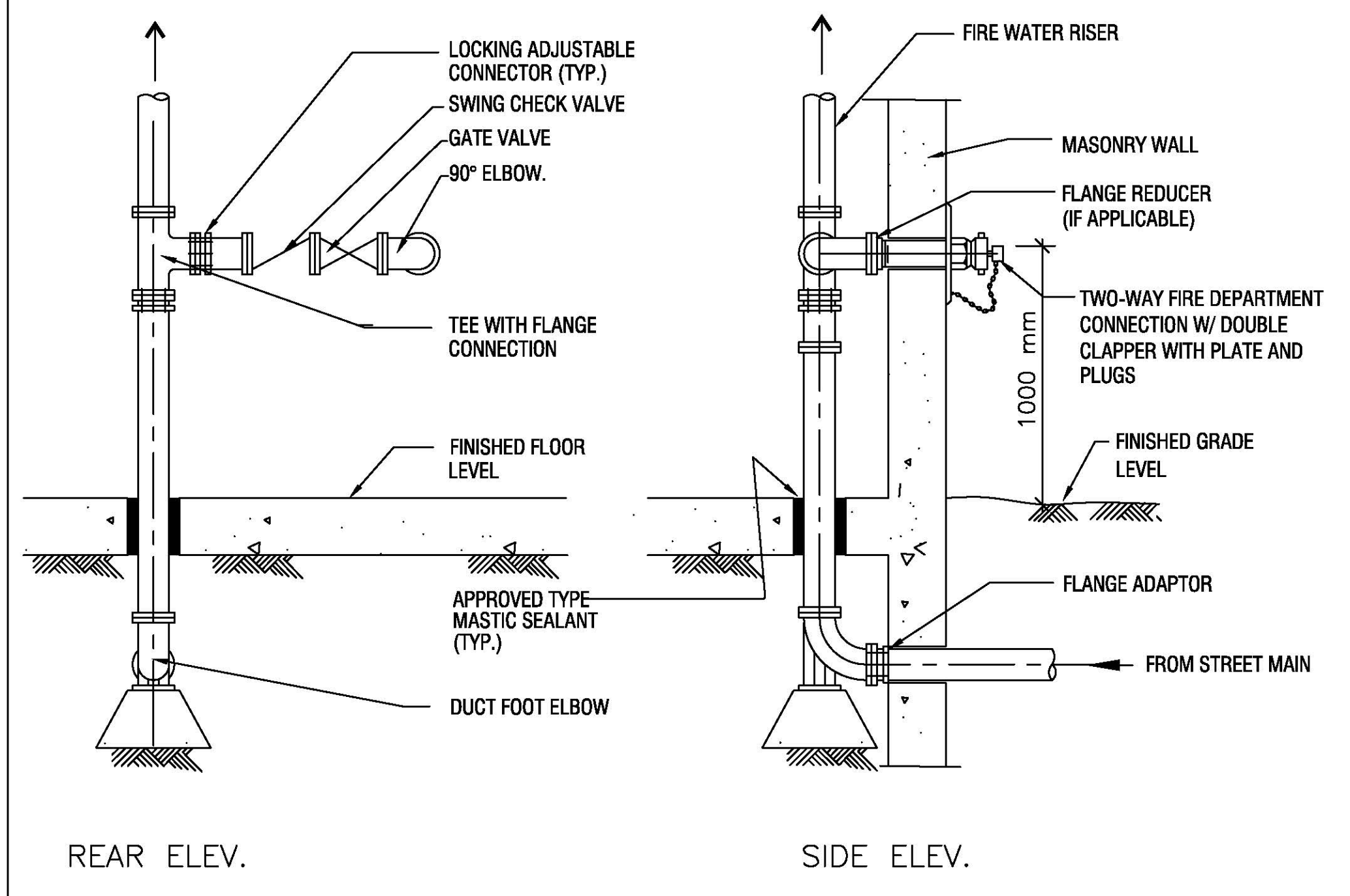

2 FIRE DEPARTMENT CONNECTION DETAIL
G-PP002 N.T.S.

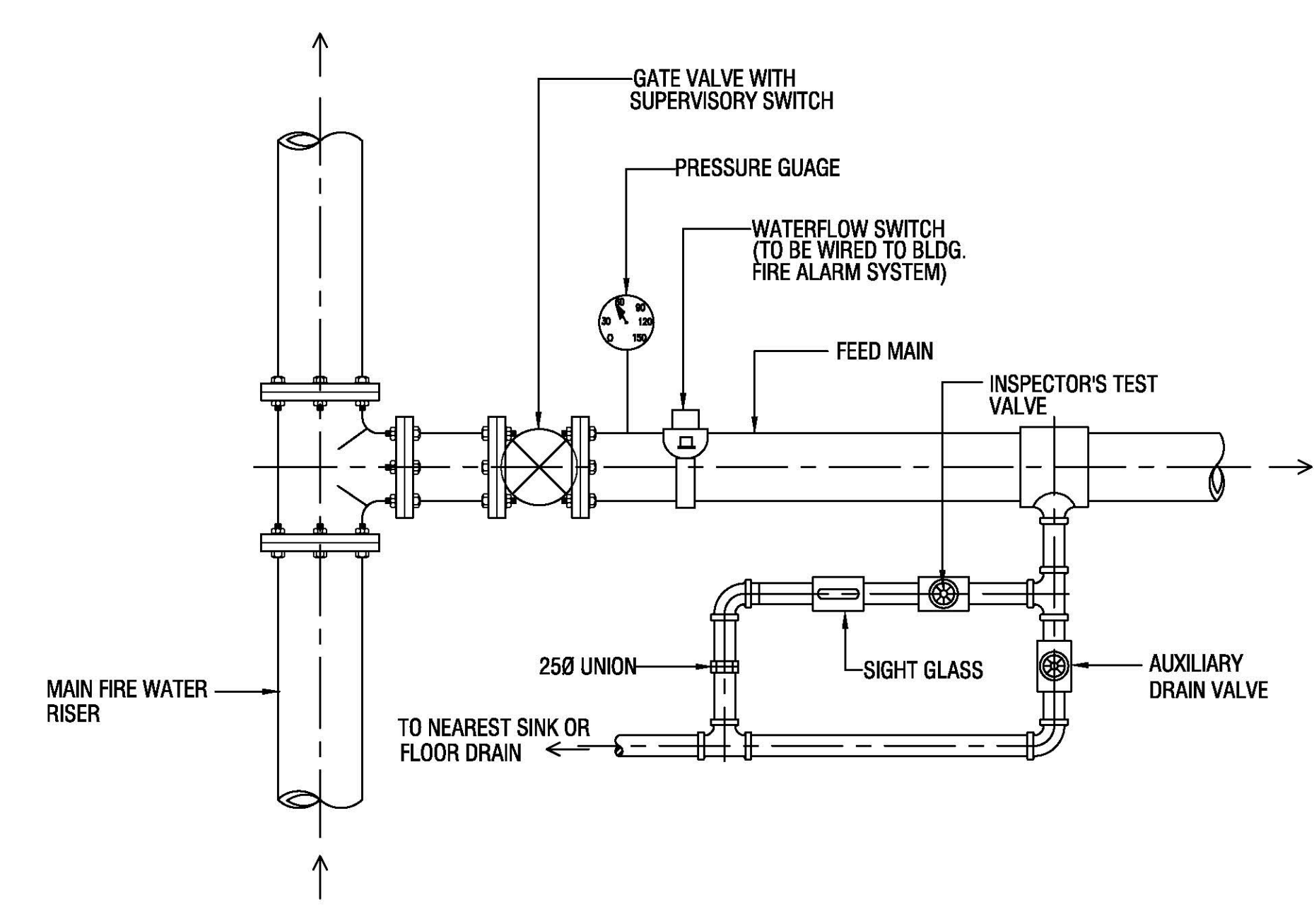

3 FLOOR CONTROL VALVE ASSEMBLY
G-PP002 N.T.S.

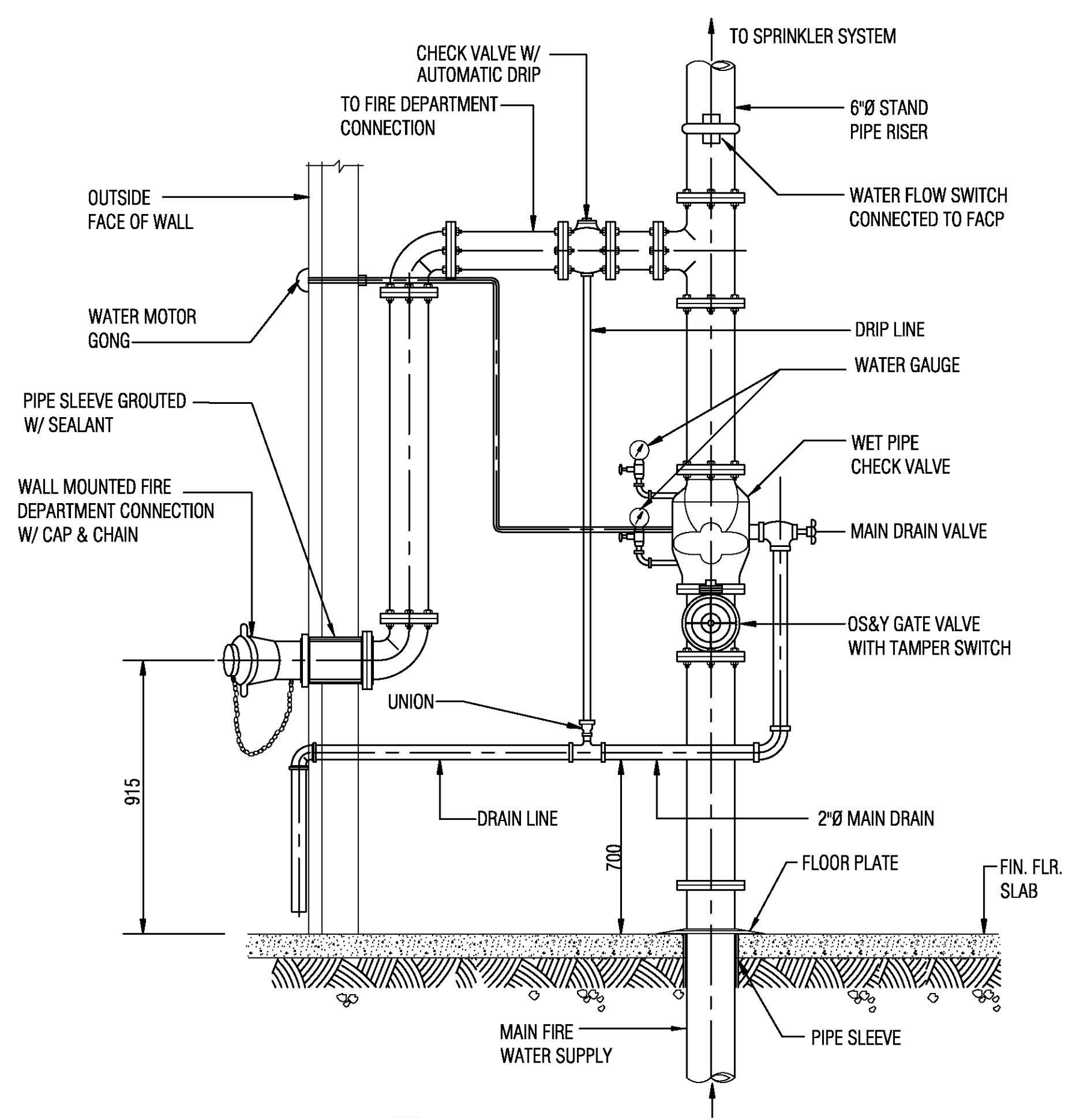

4 FIRE ALARM CHECK VALVE DETAIL
G-PP002 N.T.S.

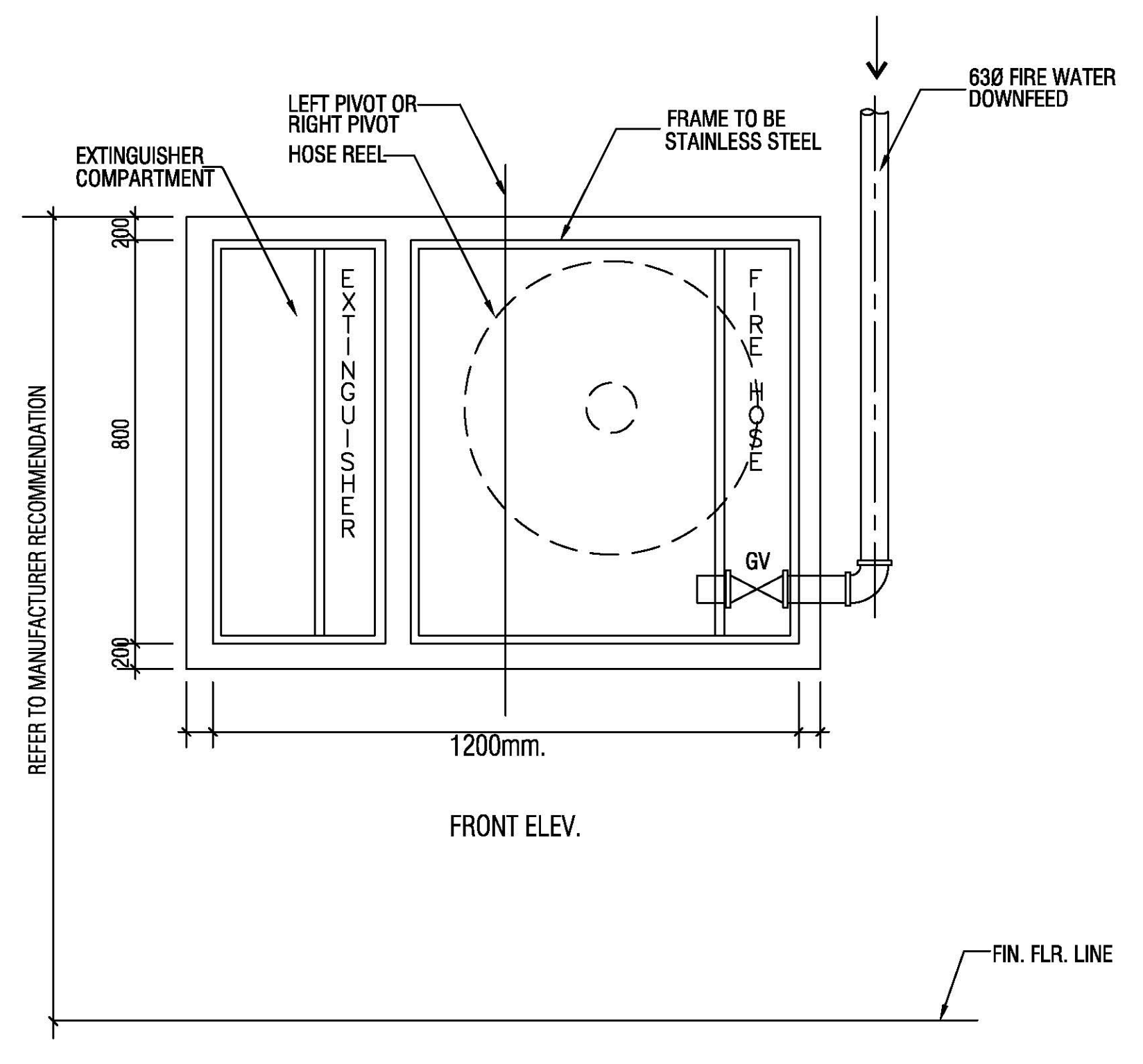

5 FIRE HOSE REEL DETAIL
G-PP002 N.T.S.

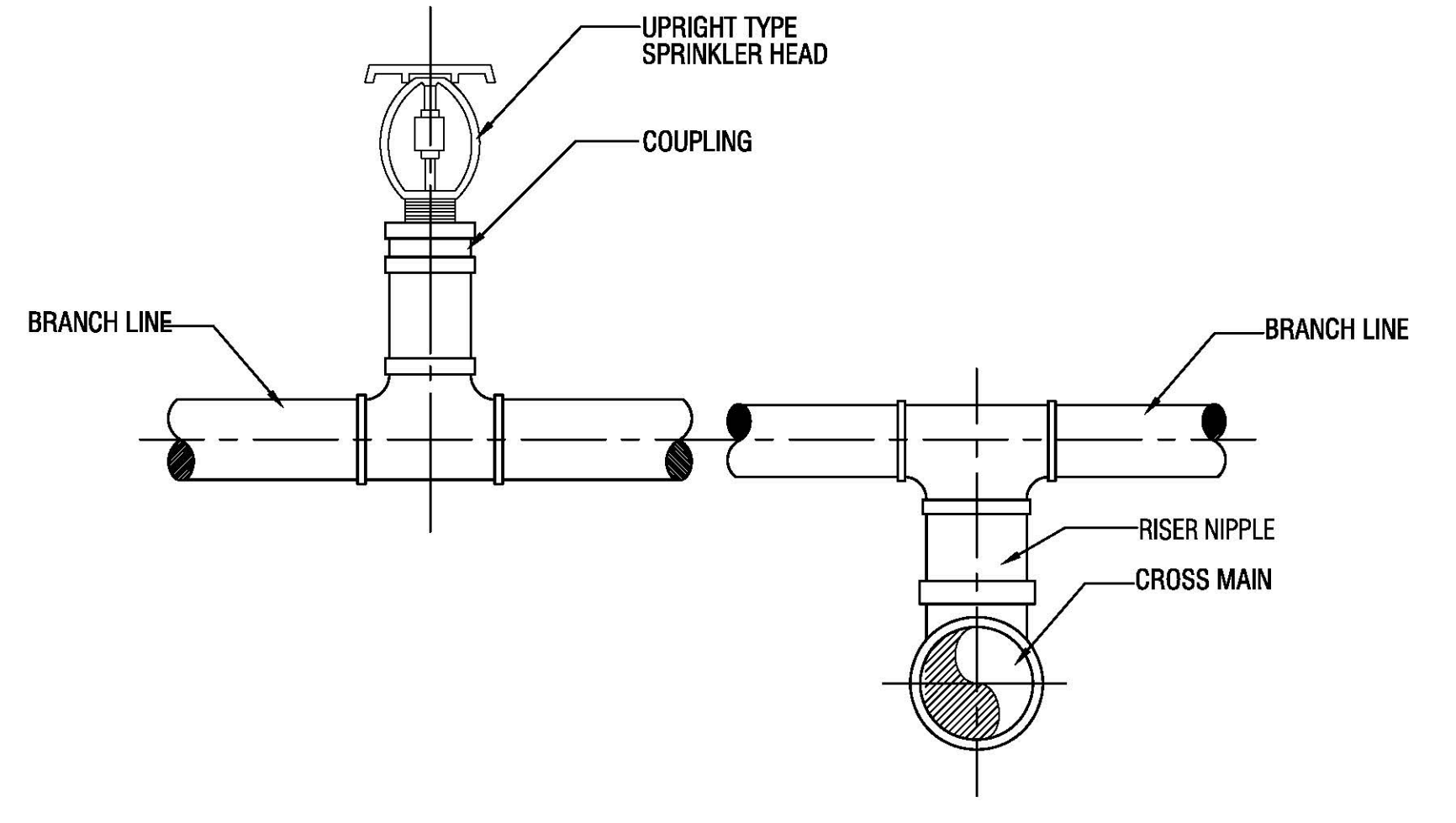

6 UPRIGHT TYPE SPRINKLER DETAIL
G-PP002 N.T.S.

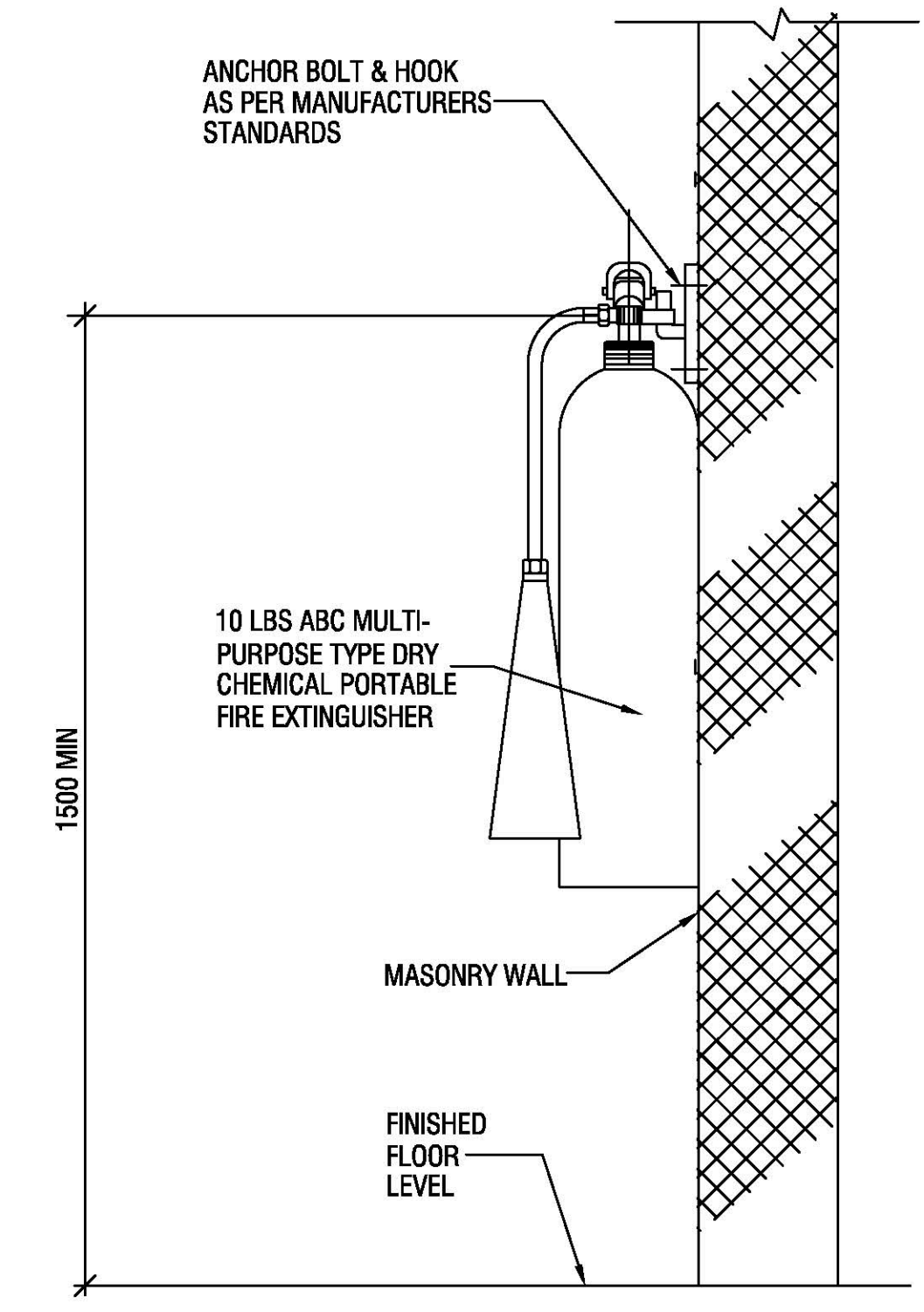

7 PORTABLE FIRE EXTINGUISHER MOUNTING DETAIL
G-PP002 N.T.S.

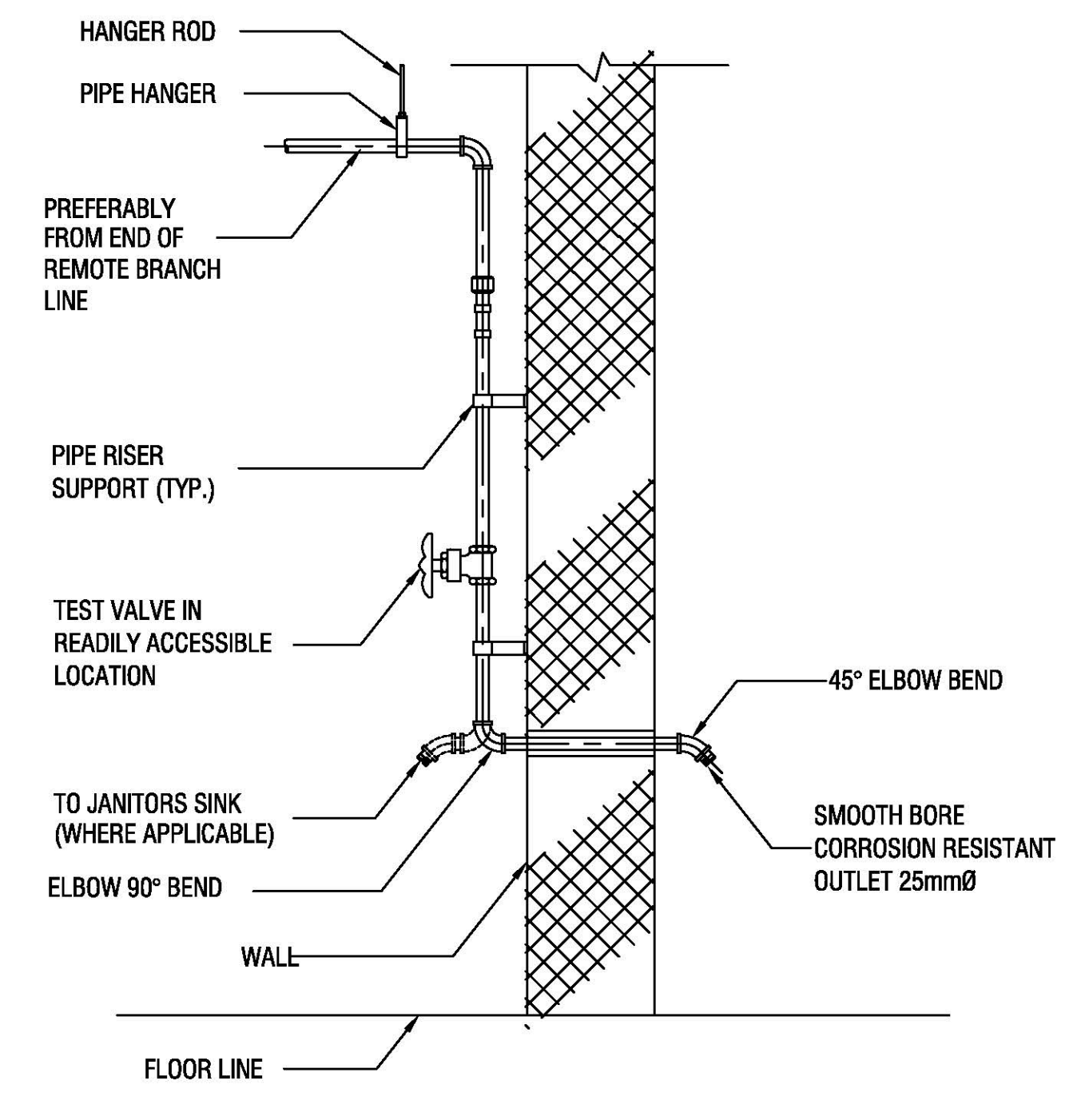

8 INSPECTOR'S TEST PIPE
G-PP002 N.T.S.

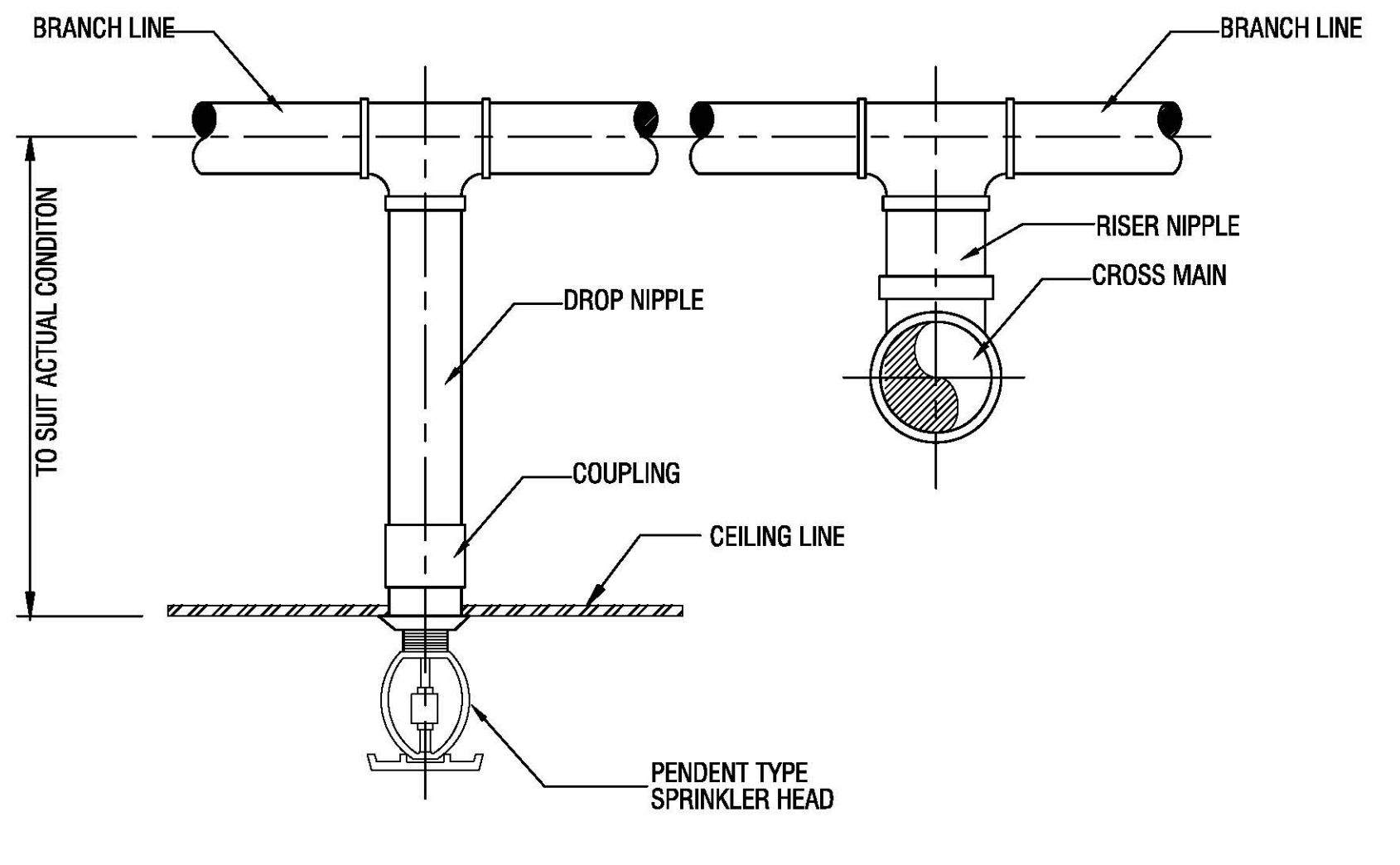

9 PENDENT TYPE SPRINKLER DETAIL
G-PP002 N.T.S.

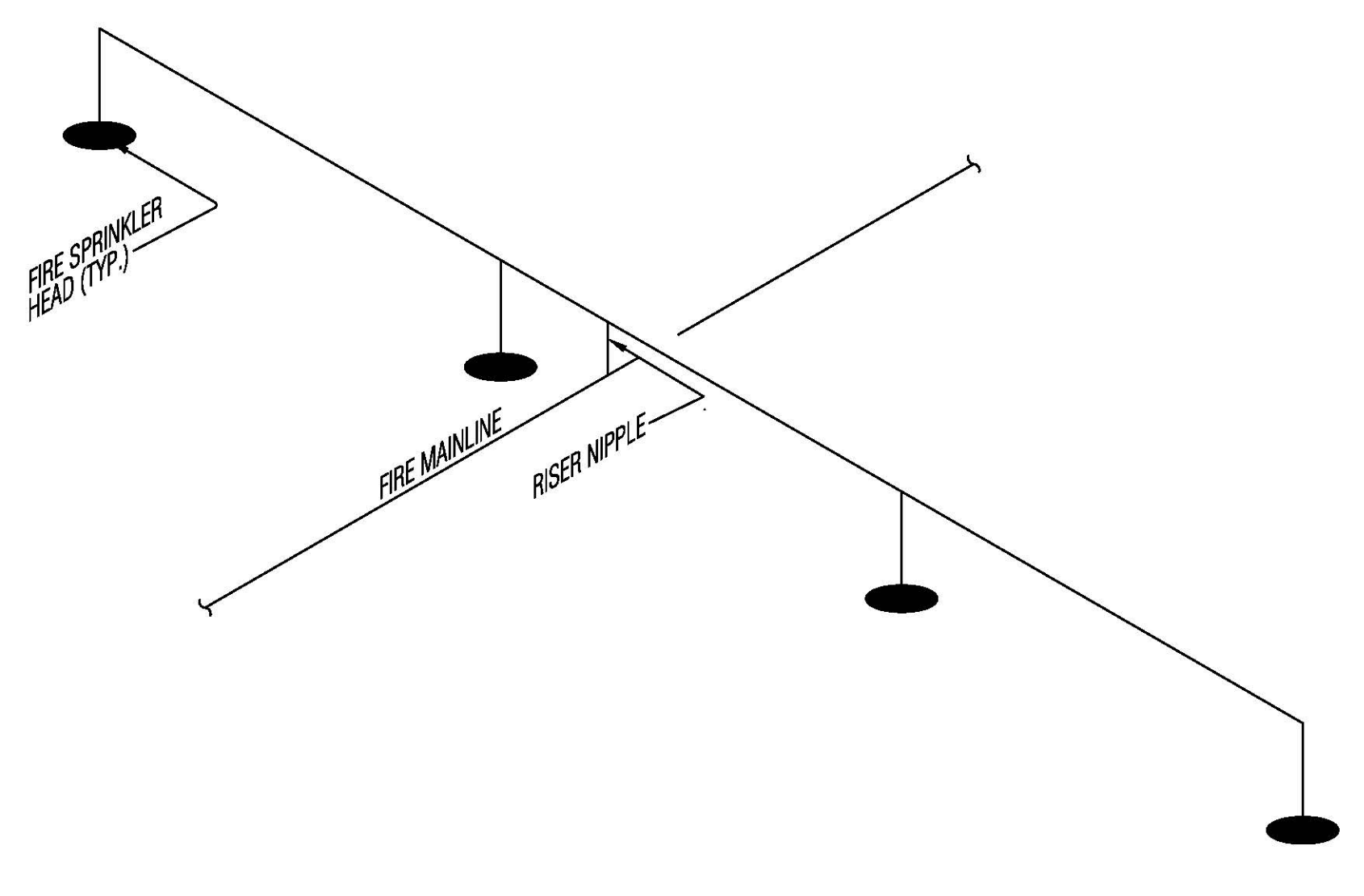

10 FIRE SPRINKLER HEAD
G-PP002 N.T.S.

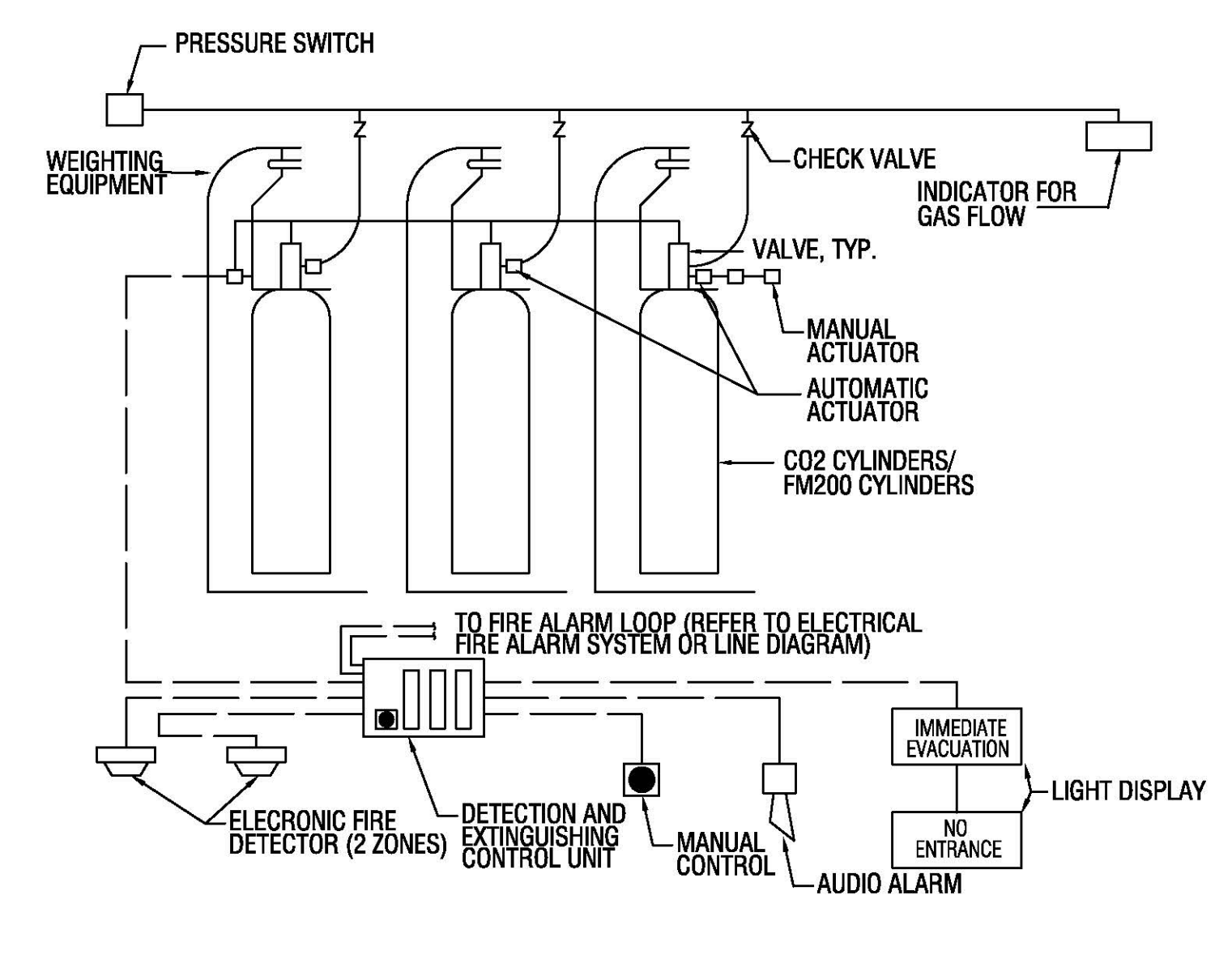

12 FM-200 & CO2 FLOODED SYSTEM SCHEMATIC
G-PP002 N.T.S.