



TECHNICAL DATA

WET PIPE SPRINKLER SYSTEM

The Viking Corporation, 210 N Industrial Park Drive, Hastings MI 49058

Telephone: 269-945-9501 Technical Services 877-384-5464 Fax: 269-945-4495 Email: techsvcs@vikingcorp.com

1. DESCRIPTION

A wet pipe sprinkler system is fixed fire protection using piping filled with pressurized water supplied from a dependable source. Closed heat sensitive automatic sprinklers spaced and located in accordance with recognized installation standards are used to detect a fire. Upon operation, the sprinklers distribute the water over a specific area to control or extinguish the fire. As the water flows through the system, an alarm is activated to indicate the system is operating. Only those sprinklers immediately over or adjacent to the fire operate, minimizing water damage.

2. APPLICATIONS

A wet pipe sprinkler system may be installed in any structure not subject to freezing to automatically protect the structure, contents, and/or personnel from loss due to fire. The structure must be substantial enough to support the piping system filled with water. Using water as its extinguishing agent, one wet system may cover as much as 52,000 square feet in a single fire area. The system should be designed by qualified fire protection engineers in conjunction with insuring bodies. Sprinkler systems are engineered to meet the standards of National Fire Protection Association (see N.F.P.A. Pamphlet 13, "The Installation of Sprinkler Systems"), Factory Mutual (F.M.), Loss Prevention Council (FOC), Assemblée Pleniére, Verband der Sachversicherer or other similar organizations, and also with the provisions of governmental codes, ordinances, and standards where applicable.

Small unheated areas of a building may be protected by a wet system if an antifreeze-loop or auxiliary dry system is installed. For rules and limitations, see appropriate codes and standards.

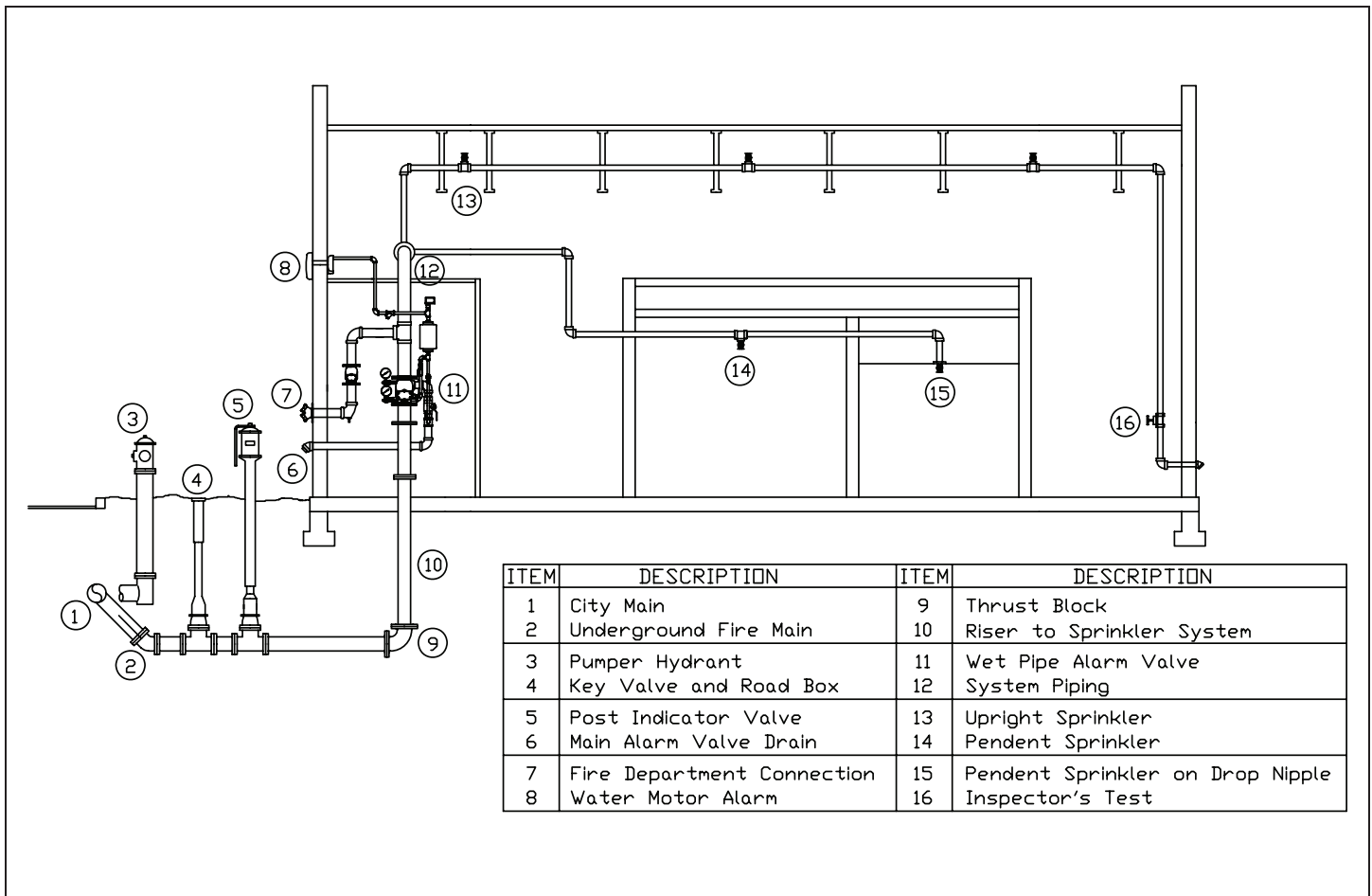



TECHNICAL DATA

WET PIPE SPRINKLER SYSTEM

The Viking Corporation, 210 N Industrial Park Drive, Hastings MI 49058

Telephone: 269-945-9501 Technical Services 877-384-5464 Fax: 269-945-4495 Email: techsvcs@vikingcorp.com

3. WET PIPE SPRINKLER SYSTEM WITH VIKING ALARM VALVE

A. SYSTEM OPERATION

In the normal set condition, the system piping is filled with water. When a fire occurs, the heat operates a sprinkler allowing the water to flow. The alarm valve clapper is opened by the flow of water allowing pressurized water to enter the alarm port to activate the connected alarm devices. When using variable pressure water supply, the water flowing through the alarm port overcomes the retard chamber's drain restriction, filling the retard chamber then activating the connected alarm devices. The alarms will continue to sound until the flow of water is manually turned off.

B. NORMAL CONDITIONS

1. All water supply control valves open and secured.
2. Alarm test shut-off valve in ALARM position.
3. Water gauge valves open.
4. The water supply pressure gauge (lower gauge) equals that of the known service-line pressure. The system pressure gauge (upper gauge) reading is equal to or greater than the water supply pressure gauge reading.
5. Incoming power to all alarm switches on.
6. Main-drain valve, auxiliary drain valves and inspectors test valves tightly closed.
7. The sprinkler head cabinet contains appropriate replacement sprinklers and wrenches.
8. Temperature maintained above freezing for entire system.
9. If Fire Department connection is used, make sure the automatic drip valve is free, allowing accumulated water to escape.
10. Sprinklers in good condition and unobstructed.

C. SYSTEM TEST

INSPECTIONS: It is imperative that the system be inspected and tested on a regular basis. The following recommendations are minimum requirements. The frequency of the inspections may vary due to contaminated or corrosive water supplies and corrosive atmospheres. In addition, the alarm devices or other connected equipment may require more frequent inspections. Refer to the technical data, system description, applicable codes, and the authority having jurisdiction for minimum requirements. Prior to testing the equipment, notify appropriate personnel.

1. **Alarm Test:** At least quarterly, test all connected alarm devices by opening the remote inspectors test valve. When weather conditions or other circumstances prohibit using the inspectors' test valve, the alarms shall be tested by turning the alarm test shut-off valve to the TEST position. When testing is complete return the valve to the ALARM position.
2. **Riser Flow Test:** At least quarterly, perform a riser flow test. Observe and record the supply pressure gauge reading. Open the main drain valve fully. The alarm should sound. Again observe and record the supply pressure gauge reading. Close the main drain valve. If the readings vary significantly from those previously established or from normal, check the main supply line for obstructions or closed valves and correct.
3. **General:** During all inspections, testing, and maintenance activities the valve, trim, piping, alarm devices, and connected equipment must be visually inspected for physical damage, freezing, corrosion, or other conditions that may inhibit the proper operation of the system.

D. TROUBLESHOOTING

1. General
 - a. Alarm fails to sound on test: clean water motor and strainers in the alarm line. Check bell for obstructions. If the alarm still fails, call your Viking representative.
 - b. Water supply pressure gauge drops on the flow test: immediately check roadway valve and post indicator or control valve. If both are open, immediately call your Viking representative, as a line obstruction is indicated.
 - c. Alarm sounds immediately on alarm test: clean orifice tee or retarding chamber drain restriction.
2. Intermittent alarms: bleed air from the high points of the system. If system pressure is seldom, if ever, greater than supply pressure, drain the system and check the alarm valve rubber and by-pass check valve rubber for cold flow and sealing efficiency. Clean valve seats and replace rubbers as necessary.
3. **False Alarms:** If water pressure surges produce false alarms, check the following:
 - a. Make sure the valve has been trimmed exactly as shown on Viking trim sheets with no deviations. The trim size and fitting arrangement is required for proper operation.
 - b. Air trapped in the sprinkler piping can cause false alarms, the alarms to cycle on and off during testing, and other nuisance problems. To correct, bleed as much air as possible from the trapped high points of system piping. This condition can be minimized by opening the remote inspector test valve and slowly filling the system with water when placing the system in service.



TECHNICAL DATA

WET PIPE SPRINKLER SYSTEM

The Viking Corporation, 210 N Industrial Park Drive, Hastings MI 49058

Telephone: 269-945-9501 Technical Services 877-384-5464 Fax: 269-945-4495 Email: techsvcs@vikingcorp.com

- c. Clean drain restriction on retard chamber trim.
- d. Clean or replace check valve on external by-pass trim.
- e. Clean or replace alarm valve clapper rubber.
- f. Add retard chamber and drain restriction if not provided.

E. REMOVING THE SYSTEM FROM SERVICE

WARNING: The system should be placed out of service only for repairs. The work to be done must be completed in a manner to minimize the time that the system must be out of service. All hazardous activities in the effected area shall be terminated until the system is placed back in service. Any system impairment shall be coordinated with the owner, local authority having jurisdiction, and other related parties. Place a roving fire patrol in the area covered by the system until the system is back in service. Prior to turning off any valves or activating any alarms, notify local security guards and/or central alarm station (if used) so that a false alarm will not be signaled and result in a local fire department response.

1. Close the water supply control valve.
2. Open the main drain valve.
3. Open all auxiliary drain valves and inspectors test valve.
4. System and supply pressure gauges should now read zero.
5. If system will be subject to freezing, drain any trapped water in the system, devices, valve, and trim.
6. Place a system-out-of-service sign in a visible location.

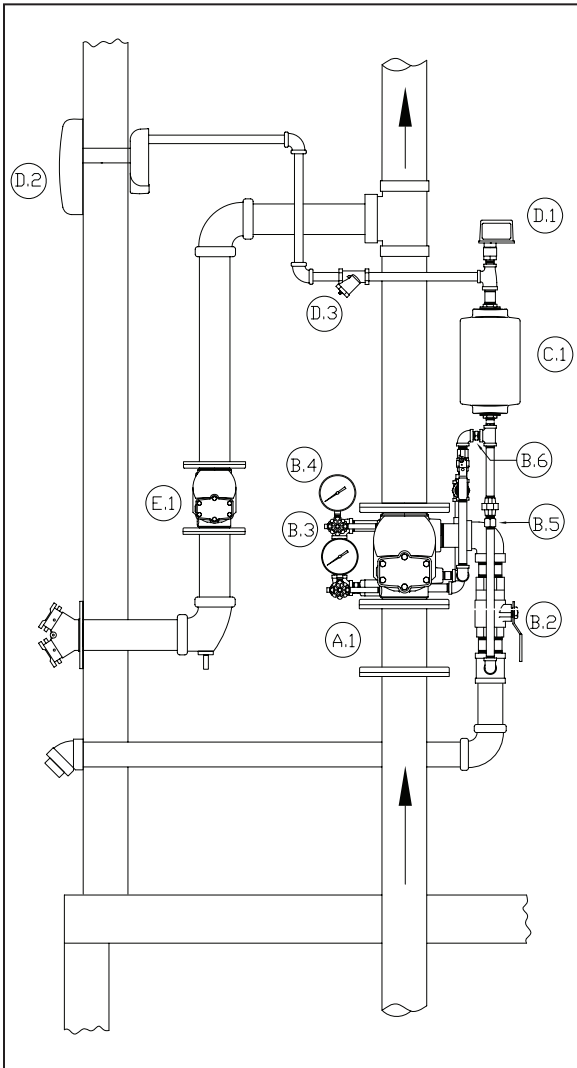

	Component	Description	Part Numbers	Corresponding Data Pages
A	System Valve			
	A.1	Alarm Check Valve	Various	26a-g
B	Check Valve Trim including:			
	B.1	Check Valve (not shown)	Various	or 28a-c
	B.2	Main Drain Valve		
	B.3	Side Outlet Valve		
	B.4	Water Gauge		
	B.5	Restriction		
	B.6	Restricted Orifice		
B.7	Restricted Orifice (not shown)			
C	C.1	Retard Chamber	05904B	38a-b
D	Water Flow Alarm Equipment			
	D.1	Alarm Pressure Switch	09470	705a-b
	D.2	Water Motor Alarm	07862	711a-d
	D.3	Alarm Line Strainer	01489A	711a-d
E	Check Valve			
	E.1	Swing Check Valve	Various	803a-d

Note: When viewing this data page online, blue text represents hyperlinks and will open the desired data page when clicked.



TECHNICAL DATA

WET PIPE SPRINKLER SYSTEM

The Viking Corporation, 210 N Industrial Park Drive, Hastings MI 49058

Telephone: 269-945-9501 Technical Services 877-384-5464 Fax: 269-945-4495 Email: techsvcs@vikingcorp.com

4. WET PIPE SPRINKLER SYSTEM WITH VIKING EASY RISER® SWING CHECK VALVE AND WATERFLOW INDICATOR

A. SYSTEM OPERATION

In the normal set condition, the system piping is filled with water. When a fire occurs, the heat operates a sprinkler allowing the water flow. The waterflow indicator is activated by the water flow. The paddle, which normally lies motionless inside the pipe, is forced up, thereby activating the pneumatic time delay mechanism which closes or opens a microswitch after the preset retard time has elapsed. This action causes an electric alarm to sound. All alarms will continue to sound as long as there is a flow of water in the system. The water will continue to flow until it is shut off manually.

B. NORMAL CONDITIONS

1. All water supply control valves open and secured.
2. Water gauge valves open.
3. The water supply pressure gauge (lower gauge) equals that of the known service-line pressure. The system pressure gauge (upper gauge) reading is equal to or greater than the water supply pressure gauge reading.
4. Incoming power to all alarm switches on.
5. Main-drain valve, auxiliary drain valves, and inspectors test valves tightly closed.
6. The sprinkler head cabinet contains appropriate replacement sprinklers and wrenches.
7. Temperature maintained above freezing for entire system.
8. If Fire Department connection is used, make sure the automatic drip valve is free, allowing accumulated water to escape.
9. Sprinklers in good condition and unobstructed.

C. SYSTEM TEST

INSPECTIONS: It is imperative that the system be inspected and tested on a regular basis. The following recommendations are minimum requirements. The frequency of the inspections may vary due to contaminated or corrosive water supplies and corrosive atmospheres. In addition, the alarm devices or other connected equipment may require more frequent inspections.

Refer to the technical data, system description, applicable codes, and the authority having jurisdiction for minimum requirements. Prior to testing the equipment, notify appropriate personnel.

1. **Alarm Test:** At least quarterly, test all connected alarm devices by opening the remote inspectors test valve
2. **Riser Flow Test:** At least quarterly perform a riser flow test. Observe and record the supply pressure gauge reading. Open the main drain valve fully. Again observe and record the supply pressure gauge reading. Close the main drain valve. If the readings vary significantly from those previously established or from normal, check the main supply line for obstructions or closed valves and correct.
3. **General:** During all inspections, testing, and maintenance activities, the valve, trim, piping, alarm devices, and connected equipment must be visually inspected for physical damage, freezing, corrosion, or other conditions that may inhibit the proper operation of the system.

D. TROUBLESHOOTING

1. General
 - a. Alarm fails to sound on test: Check bell for obstructions. Check power source and wiring. If the alarm still fails, call your Viking representative.
 - b. Water supply pressure gauge drops on the flow test: immediately check roadway valve and post indicator or control valve. If both are open, immediately call your Viking representative, since a line obstruction is indicated.
 - c. Alarm sounds immediately on alarm test: During surges, the paddle will move. The switch mechanism is provided with a pneumatic time delay to prevent closing of the alarm line circuit. The time delay can be adjusted from 0 to 90 seconds (see the waterflow indicator device page).
 - d. Intermittent alarms - bleed air from the high points of the system. If system pressure is seldom, if ever, greater than supply pressure, drain the system and check the check valve rubber for cold flow and sealing efficiency. Clean valve seats and replace rubbers as necessary.
2. **False Alarms:** If water pressure surges produce false alarms, check the following:
 - a. Air trapped in the sprinkler piping can cause false alarms, the alarms to cycle on and off during testing and other nuisance problems. To correct bleed as much air as possible from the trapped high points of system piping. This condition can be minimized by opening the remote inspector test valve and slowly filling the system with water when placing the system in service.



TECHNICAL DATA

WET PIPE SPRINKLER SYSTEM

The Viking Corporation, 210 N Industrial Park Drive, Hastings MI 49058
 Telephone: 269-945-9501 Technical Services 877-384-5464 Fax: 269-945-4495 Email: techsvcs@vikingcorp.com

E. REMOVING THE SYSTEM FROM SERVICE

WARNING: The system should be placed out of service only for repairs. The work must be completed in a manner to minimize the time that the system must be out of service. All hazardous activities in the effected area shall be terminated until the system is placed back in service. Any system impairment shall be coordinated with the owner, local authority having jurisdiction, and other related parties. Place a roving fire patrol in the area covered by the system until the system is back in service.

Prior to turning off any valves or activating any alarms, notify local security guards and/or central alarm station (if used) so that a false alarm will not be signaled and result in a local fire department response.

1. Close the water supply control valve.
2. Open the main drain valve.
3. Open all auxiliary drain valves and inspectors test valve.
4. System and supply pressure gauges should now read zero.
5. If system will be subject to freezing, drain any trapped water in the system, devices, valve, and trim.
6. Place a system-out-of-service sign in a visible location.

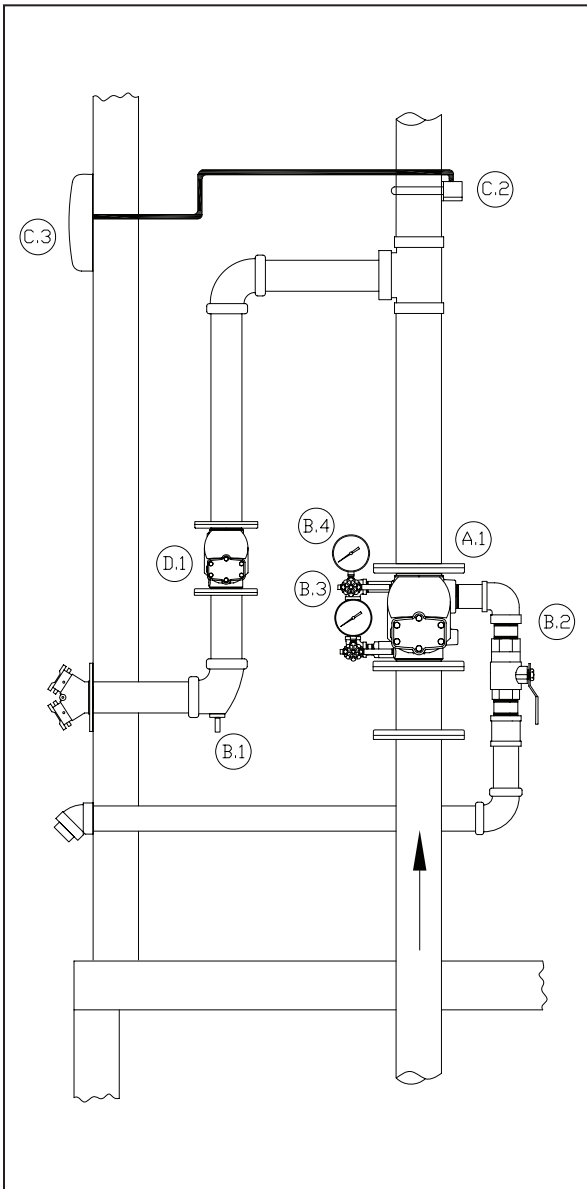

	Component	Description	Part Numbers	Corresponding Data Pages
A	System Valve			
	A.1	Easy Riser® Check Valve	Various	815a-f
B	Check Valve Trim including:			
	B.1	Automatic Drip Valve	Various	815a-f
	B.2	Main Drain Valve		
	B.3	Side Outlet Valve		
B.4	Water Gauge			
C	Water Flow Alarm Equipment			
	C.1	Alarm Pressure Switch or	09470	705a-b
	C.2	Water Flow Indicator	Various	703a-b
	C.3	Electric Alarm Bell	--	--
D	Check Valve			
	D.1	Swing Check Valve	Various	803a-d

Note: When viewing this data page online, blue text represents hyperlinks and will open the desired data page when clicked.

**THIS PAGE
INTENTIONALLY
LEFT BLANK**



Wet System

Technical Manual for Operation, Maintenance, and Troubleshooting

October, 2008

Form No. F_010508

	TECHNICAL DATA	WET PIPE SPRINKLER SYSTEM
---	-----------------------	----------------------------------

The Viking Corporation, 210 N Industrial Park Drive, Hastings MI 49058

Telephone: 269-945-9501 Technical Services 877-384-5464 Fax: 269-818-1680 Email: techsvcs@vikingcorp.com

<u>Table of Contents</u>	<u>Page</u>
I. SYSTEM DESCRIPTION	3
II. SYSTEM APPLICATIONS	4
III. SYSTEM REQUIREMENTS	5
A. Wet System Check Valves	5
B. Relief Valves	5
C. Pressure Gauges	9
IV. SYSTEM COMPONENTS	9
A. Model J-1 Alarm Check Valve	9
B. Model C-1 Retard Chamber	12
C. Water Motor Alarm	14
D. Fire Department Check Valves	16
V. OPTIONAL EQUIPMENT: VIKING EASYPAC RISER MANIFOLD ASSEMBLIES	17
VI. WATER FLOW ALARM EQUIPMENT	18
A. Alarm Pressure Switch	18
B. Waterflow Indicator	20
VII. WET SYSTEM NORMAL CONDITIONS	21
VIII. WET SYSTEM OPERATION	22
IX. WET SYSTEM INSPECTIONS, TESTS, AND MAINTENANCE	22
A. Waterflow Alarm Test	23
B. Main Drain Test	25
C. Five-Year Internal Inspection	28
D. Maintenance	30
X. REMOVING THE SYSTEM FROM SERVICE	31
XI. USE OF DRY SPRINKLERS IN WET SYSTEMS	32
XII. TROUBLESHOOTING VIKING WET SYSTEMS	32
A. Alarms Fail to Sound on Test	32
B. Water Supply Gauge Drops on the Flow Test	32
C. Alarm Sounds Immediately on Alarm Test	33
D. Intermittent Alarms	33
E. False Alarms	35



The Viking Corporation, 210 N Industrial Park Drive, Hastings MI 49058
 Telephone: 269-945-9501 Technical Services 877-384-5464 Fax: 269-818-1680 Email: techsvcs@vikingcorp.com

NOTE: SPRINKLER SYSTEMS ARE ENGINEERED TO MEET THE STANDARDS OF NFPA 13, FM GLOBAL, LOSS PREVENTION COUNCIL (FOC), ASSEMBLEE PLENIERE, VERBAND DER SACHVERSICHERER (VDS) OR OTHER SIMILAR ORGANIZATIONS, AND WILL ALSO NEED TO COMPLY WITH THE PROVISIONS OF GOVERNMENTAL CODES, ORDINANCES, AND STANDARDS WHERE APPLICABLE. THE SYSTEM MUST BE DESIGNED BY QUALIFIED DESIGN PROFESSIONALS IN CONJUNCTION WITH INSURING BODIES. THE USER IS RESPONSIBLE FOR THE DESIGN AND CONFIGURATION OF THE SYSTEM, ITS APPROPRIATENESS FOR THE USE INTENDED AND ITS COMPLIANCE WITH ALL STANDARDS, CODES AND ORDINANCES. VIKING CORPORATION DOES NOT DESIGN SYSTEMS FOR SPECIFIC INSTALLATIONS AND MAKES NO REPRESENTATION OR WARRANTY CONCERNING WHETHER ANY SPECIFIC SYSTEM INSTALLATION WILL BE SUFFICIENT FOR THE INTENDED USE OR WILL COMPLY WITH ANY STANDARD, CODE, OR ORDINANCE. ANY SYSTEM DEPICTED IN THIS MANUAL IS SHOWN FOR ILLUSTRATIVE PURPOSES ONLY.

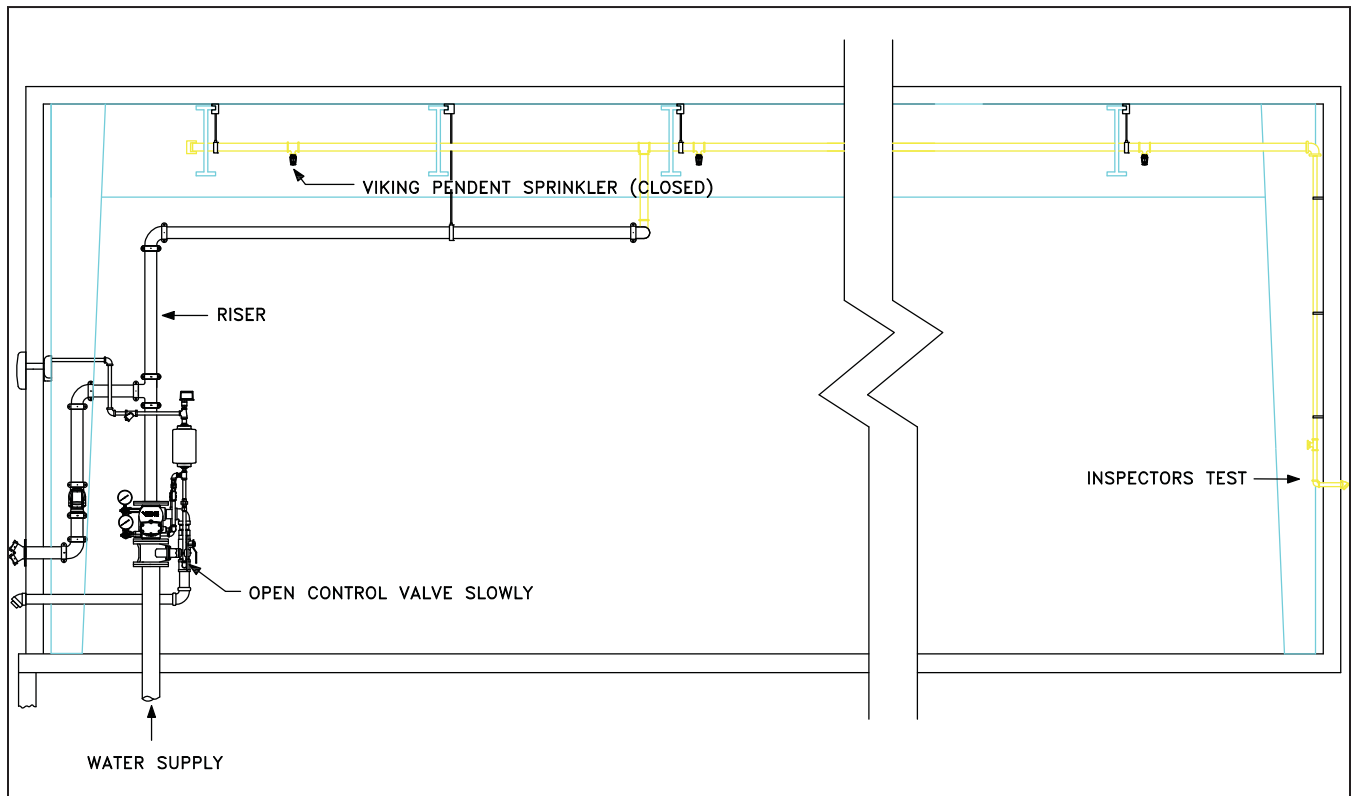

Figure 1

I. SYSTEM DESCRIPTION

Wet systems are the simplest and most common type of sprinkler system installation, with relatively few components (Figures 1 and 2). The system provides fixed fire protection using piping filled with pressurized water supplied from a dependable source at all times. Water is continually discharged through sprinklers that have activated over or near the fire, thereby minimizing water damage. Closed heat-sensitive automatic sprinklers spaced and located in accordance with recognized installation standards are used to detect a fire. Upon operation, the sprinklers distribute the water over a specific area to control or extinguish the fire.

This technical manual will cover Viking wet pipe system design calculation, trim parts and their functions, as well as describe the proper operation, maintenance, and repair of valves and system devices.

	TECHNICAL DATA	WET PIPE SPRINKLER SYSTEM
---	-----------------------	----------------------------------

The Viking Corporation, 210 N Industrial Park Drive, Hastings MI 49058

Telephone: 269-945-9501 Technical Services 877-384-5464 Fax: 269-818-1680 Email: techsvcs@vikingcorp.com

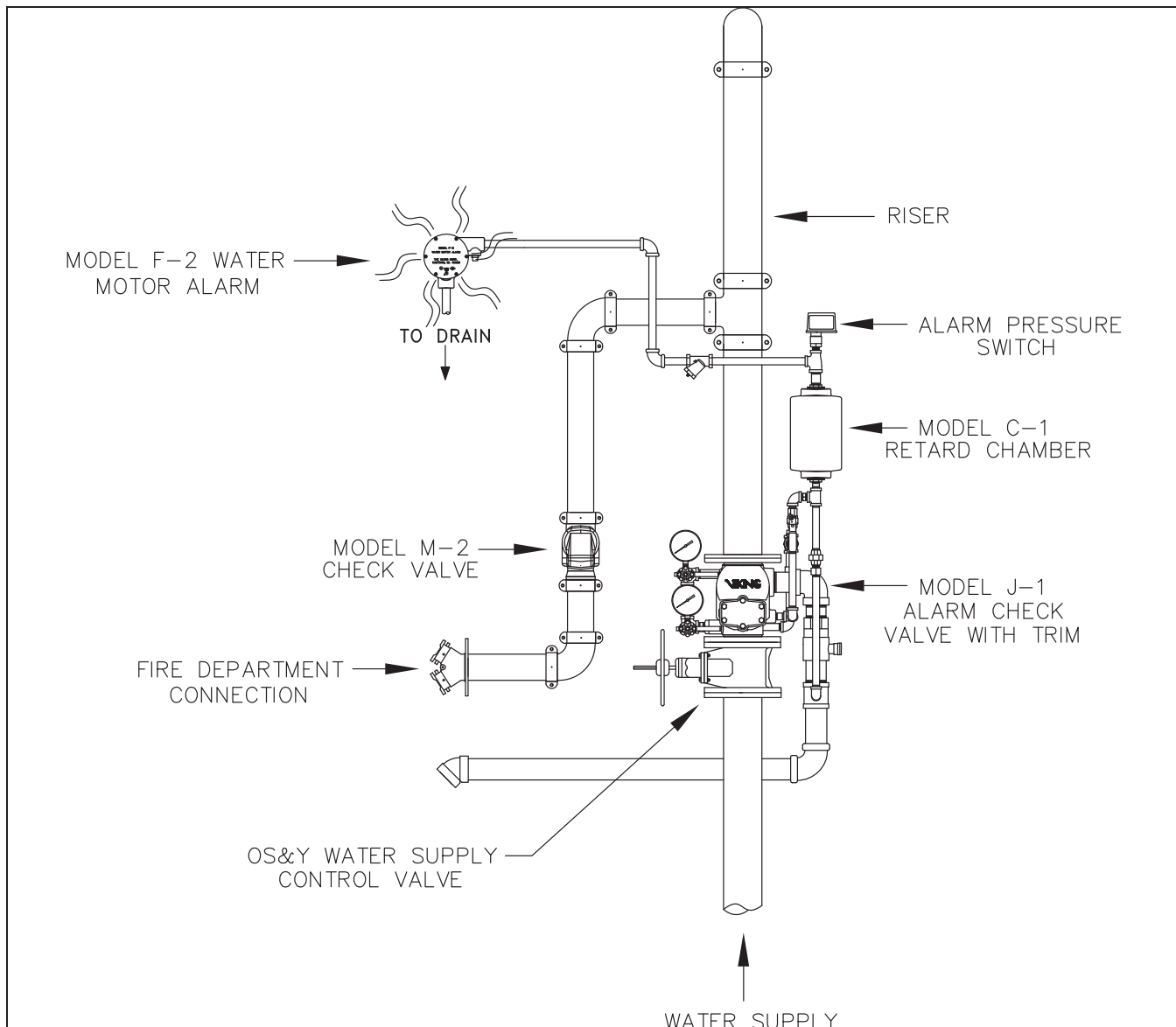

Figure 2

II. SYSTEM APPLICATIONS

Wet pipe sprinkler systems may be installed in any structure that is reliably maintained above 40 °F (4 °C), to automatically protect the structure, contents, and/or personnel from loss due to fire. Using water as its extinguishing agent, one wet system riser (or combined system riser) may cover as much as 52,000 square feet of floor area on any one floor, for light and ordinary hazard. (For extra hazard - hydraulically calculated, and storage occupancies, the limit is 40,000 square feet. For extra hazard - pipe schedule, the limit is 25,000 square feet.) Note that NFPA 13 limits the maximum area of each floor; it doesn't limit the number of floors that can be protected by a single riser.

The system should be designed by qualified design professionals in conjunction with insuring bodies. Sprinkler systems are engineered to meet the standards of NFPA 13, FM Global, Loss Prevention Council (FOC), Assemblée Plenièrre, Verband der Sachversicherer (VdS) or other similar organizations, and also with the provisions of governmental codes, ordinances, and standards where applicable.



The Viking Corporation, 210 N Industrial Park Drive, Hastings MI 49058
 Telephone: 269-945-9501 Technical Services 877-384-5464 Fax: 269-818-1680 Email: techsvcs@vikingcorp.com

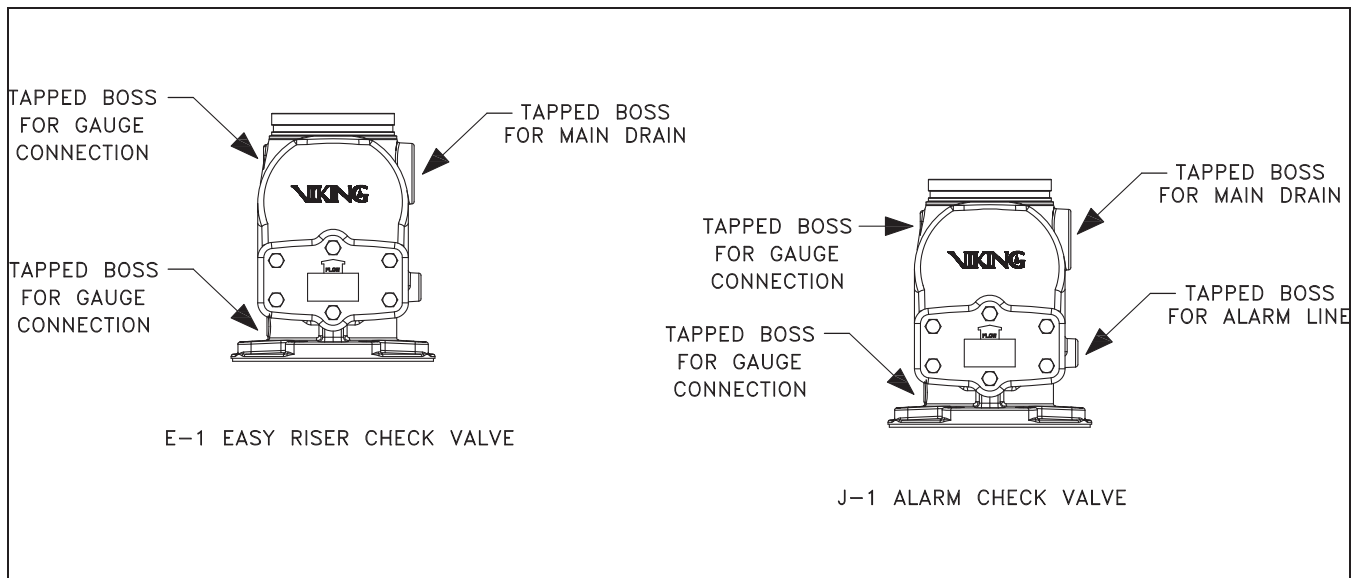

Figure 3

NOTE: Small unheated areas of a building may be protected by a wet system if an antifreeze-loop or auxiliary dry system is installed. For rules and limitations on these, refer to the appropriate codes and standards.

III. SYSTEM REQUIREMENTS

Section 7.1 of NFPA 13-2007 provides the installation rules and characteristics that are unique to wet systems. Hydraulic calculations are required to verify that the system's overall layout is compliant with NFPA 13. Chapter 22 of NFPA 13 discusses the procedures for calculating the hydraulic demand of the sprinkler system and for verifying whether the available water supply will meet the requirements.

A. Wet System Check Valves

Wet systems commonly include a Model J-1 Alarm Check Valve or a Model E-1 Easy Riser® Swing Check Valve (Figures 3-6). Both valves can be installed vertically or horizontally (with cover facing upwards) (Figure 7). The Model E-1 Easy Riser® Swing Check Valve may replace an alarm check valve when used with a flow switch on wet pipe systems not requiring a mechanical alarm. The Model E-1 serves as a system check valve with tapped bosses for gauge connections and the main drain. It is often used together with an electric vane-type water flow detector, which initiates an alarm.

B. Relief Valves

Note that NFPA 13 defines a *gridded sprinkler system* as having parallel cross mains connected by multiple branch lines so that an operating sprinkler will receive water from both ends of its branch line. Gridded systems are often preferred because of their hydraulic characteristics. Because wet pipe systems are closed systems, there is the possibility of pressure buildup above the rated working pressure of system components. Per NFPA 13, gridded wet pipe systems must be provided with a relief valve at least 1/4" (6 mm) in size, set to operate at 175 PSI (12.1 bar) or 10 PSI (0.7 bar) above the maximum system pressure, whichever is greater.

NOTE: A relief valve is not required where auxiliary air reservoirs are installed to absorb pressure increases. Because there is a limited number of air pockets that typically exist in gridded systems, and air reservoirs need to be large enough for the anticipated pressure increases, consider using an expansion chamber.



TECHNICAL DATA

WET PIPE SPRINKLER SYSTEM

The Viking Corporation, 210 N Industrial Park Drive, Hastings MI 49058
Telephone: 269-945-9501 Technical Services 877-384-5464 Fax: 269-818-1680 Email: techsvcs@vikingcorp.com

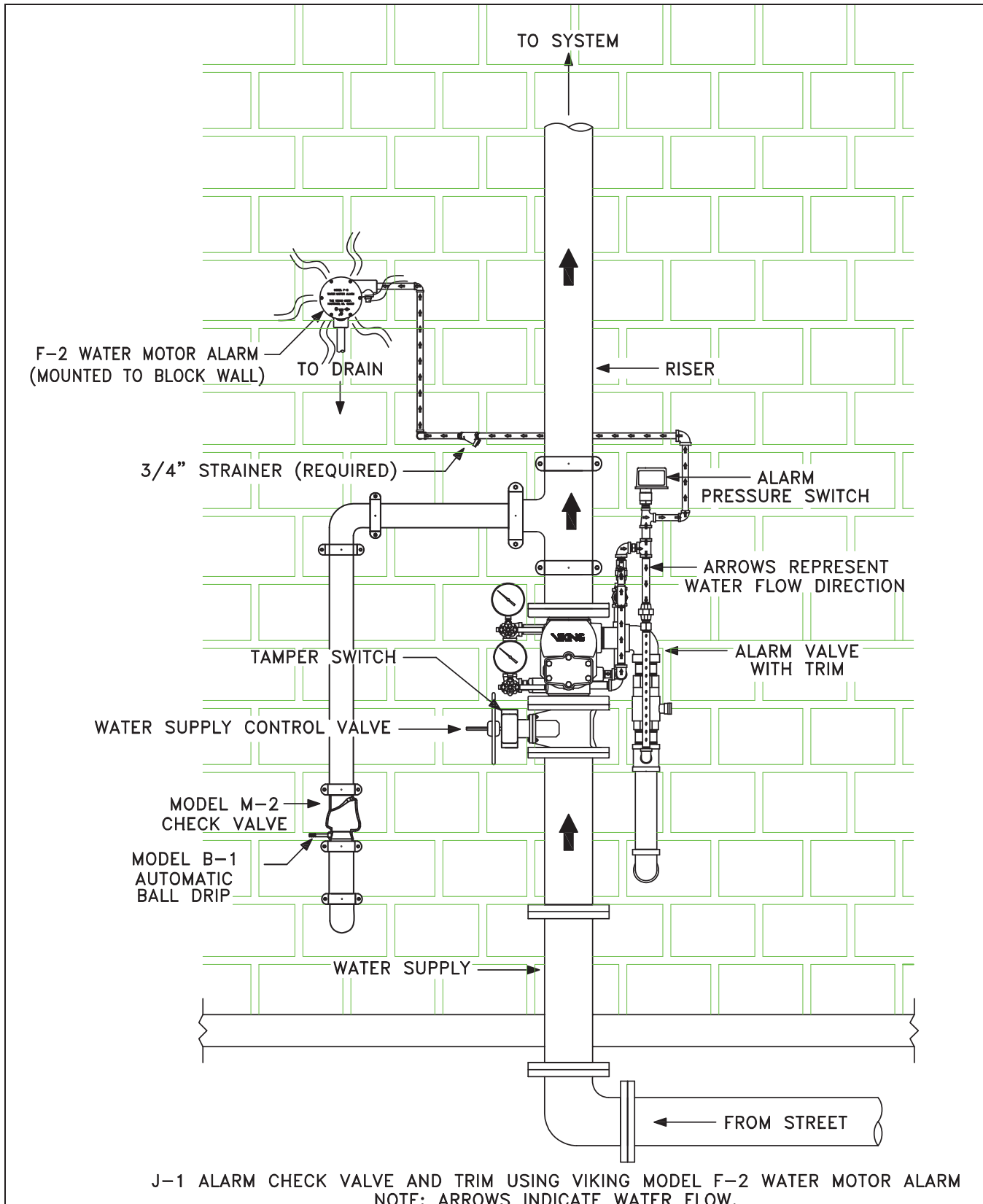

Figure 4

VIKING® TECHNICAL DATA WET PIPE SPRINKLER SYSTEM

The Viking Corporation, 210 N Industrial Park Drive, Hastings MI 49058
Telephone: 269-945-9501 Technical Services 877-384-5464 Fax: 269-818-1680 Email: techsvcs@vikingcorp.com

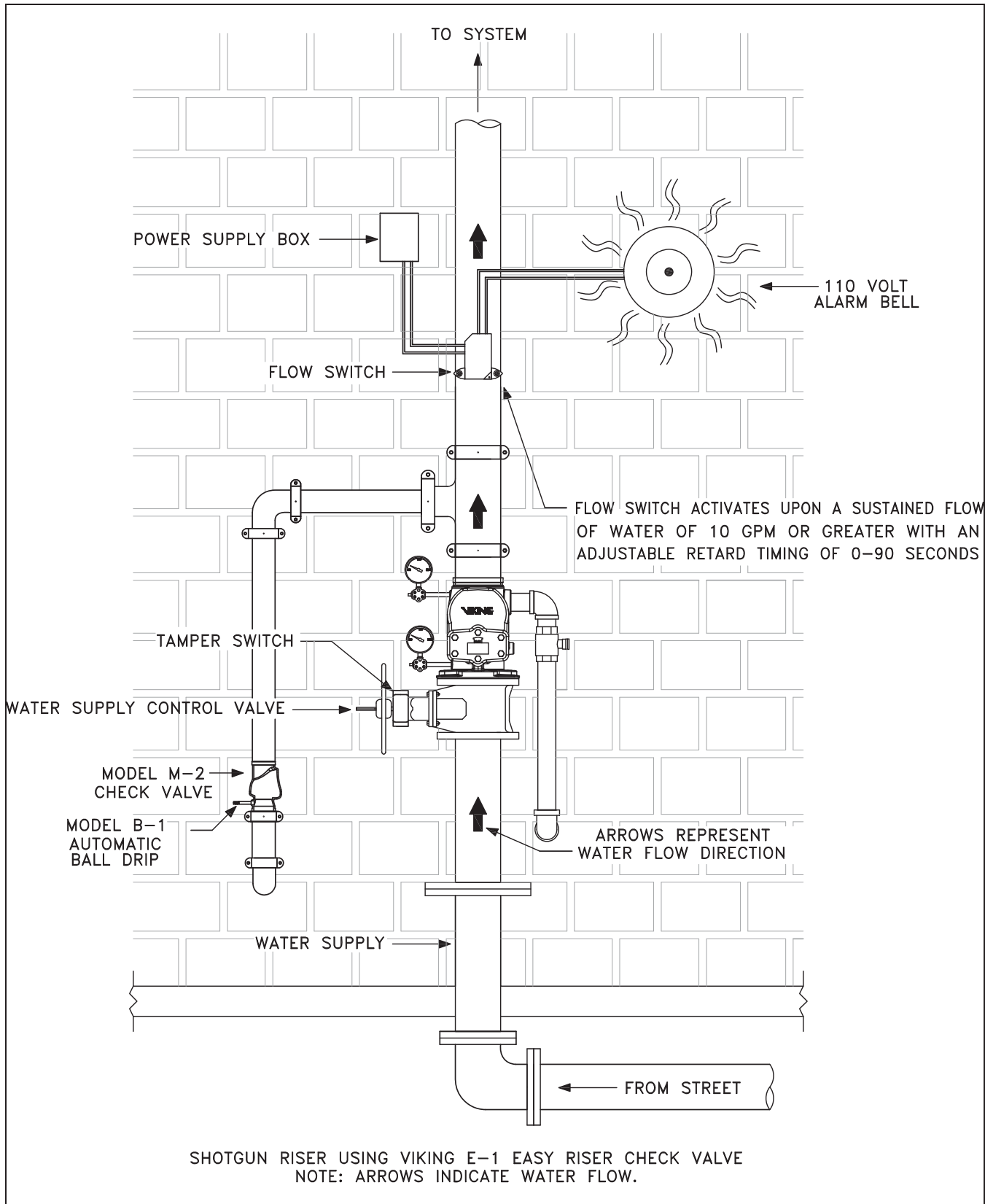

Figure 5



TECHNICAL DATA

WET PIPE SPRINKLER SYSTEM

The Viking Corporation, 210 N Industrial Park Drive, Hastings MI 49058

Telephone: 269-945-9501 Technical Services 877-384-5464 Fax: 269-818-1680 Email: techsvcs@vikingcorp.com

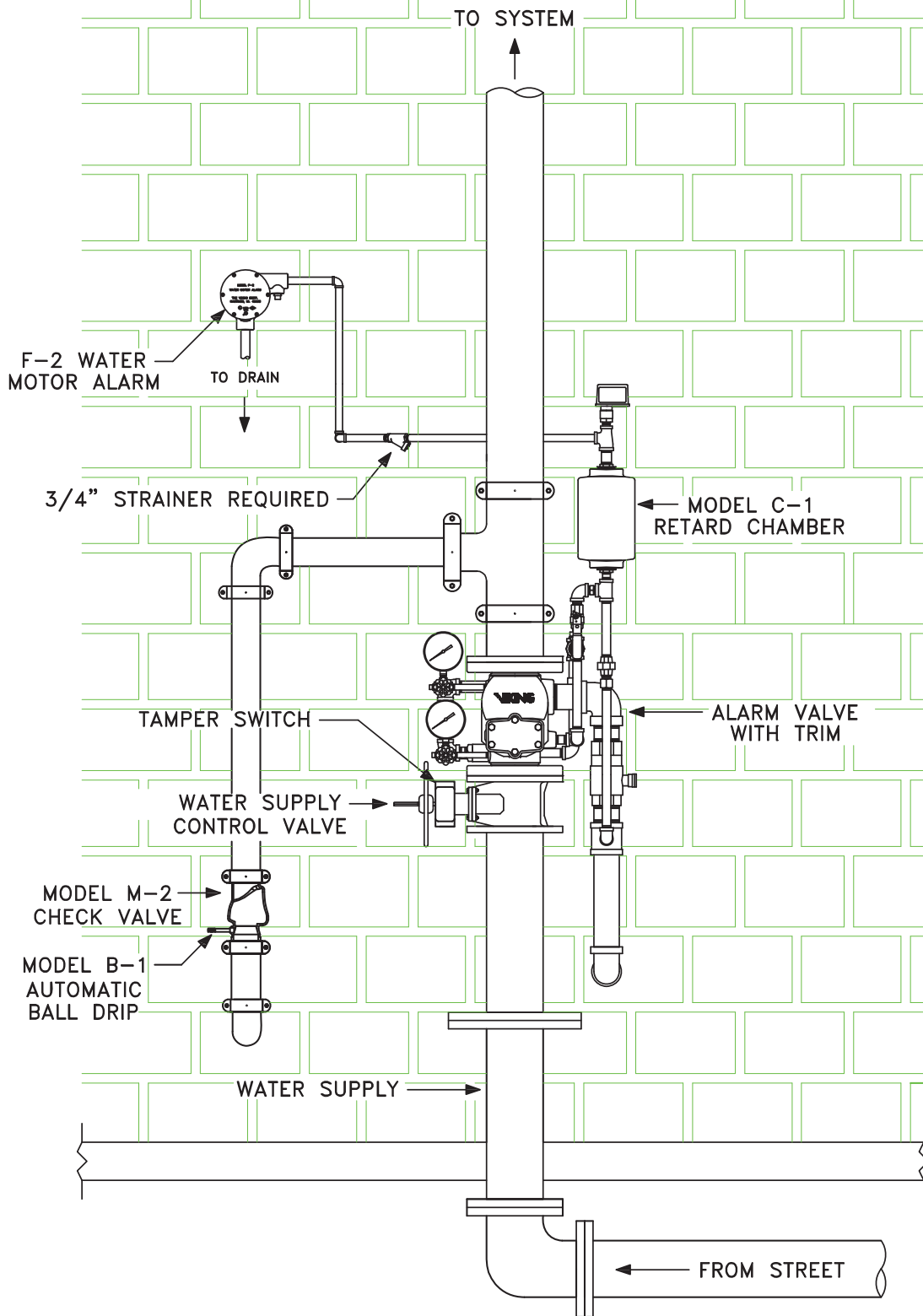

J-1 ALARM CHECK VALVE AND TRIM USING VIKING MODEL F-2 WATER MOTOR ALARM WITH A C-1 RETARD CHAMBER

Figure 6

	TECHNICAL DATA	WET PIPE SPRINKLER SYSTEM
---	-----------------------	----------------------------------

The Viking Corporation, 210 N Industrial Park Drive, Hastings MI 49058
 Telephone: 269-945-9501 Technical Services 877-384-5464 Fax: 269-818-1680 Email: techsvcs@vikingcorp.com

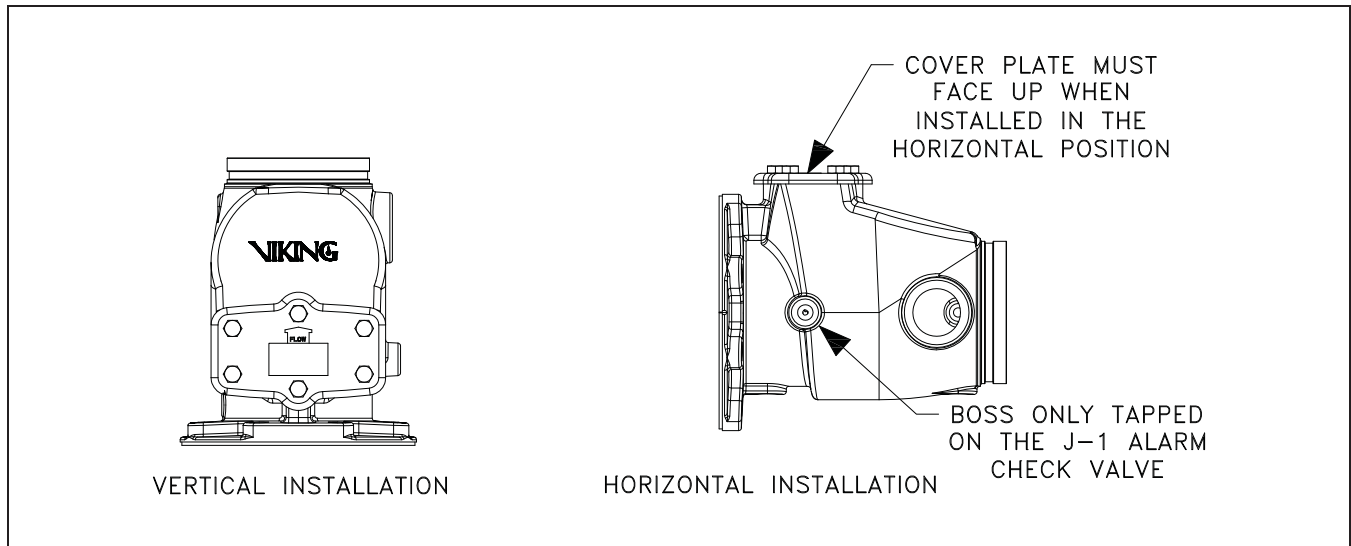

Figure 7

C. Pressure Gauges

NFPA 13 requires a listed pressure gauge (Figure 8) to be installed in each system riser. Where check valves are used, pressure gauges are to be installed above and below each alarm check valve or system riser check valve. Note: It is common for the gauge on the system side of the valve to indicate a higher pressure due to pressure surges trapped in the system by the check valve.

Readings from these gauges can be used in recording the available pressure in the water supply, while the gauge on the supply side is used during the 2 inch (50 mm) main drain test (required by NFPA 25) for residual pressures in the water supply.



Figure 8

Note: Per section 5.3.2 of NFPA 25-2008 edition, gauges must be replaced every 5 years or tested every 5 years by comparison with a calibrated gauge. Gauges are required to be accurate to within 3 percent of the full scale, otherwise they must be re-calibrated or replaced.

IV. SYSTEM COMPONENTS

A. Model J-1 Alarm Check Valve

1. Description

The Model J-1 Alarm Check Valve (Figure 9) is designed to indicate when a sprinkler has operated as well as provide a system check valve. The Model J-1 Valve serves as a check valve by trapping pressurized water above the clapper and preventing reverse flow from sprinkler piping. The valve initiates an alarm during a sustained flow of water (such as the flow required by an open sprinkler) by operating an optional water motor alarm and/or alarm pressure switch. When it is installed with the water motor alarm, the system can provide a local alarm even when electric power is lost.



Figure 9



TECHNICAL DATA

WET PIPE SPRINKLER SYSTEM

The Viking Corporation, 210 N Industrial Park Drive, Hastings MI 49058

Telephone: 269-945-9501 Technical Services 877-384-5464 Fax: 269-818-1680 Email: techsvcs@vikingcorp.com

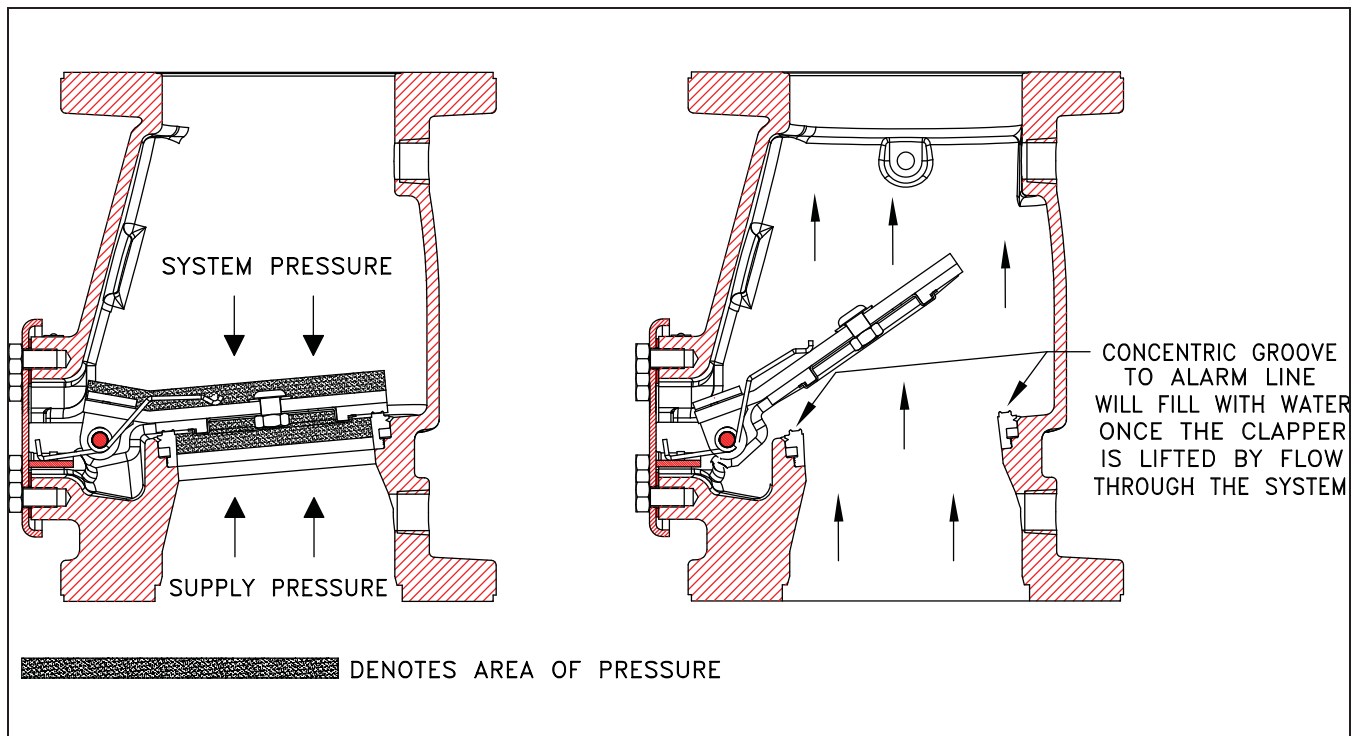

Figure 10

The valve has a divided seat ring with a concentric groove (Figure 10) and a piped connection from the groove to the alarm device. Note that the area of the clapper subject to system side pressure is slightly larger than that subject to supply side pressure. This design allows the clapper to resist water surges and other minor flow fluctuations without opening. When the clapper of the valve rises to allow flow from the sprinklers, water also enters the groove in the divided seat ring and flows to the alarm devices (Figure 11). The Model J-1 Valve is made suitable for use on variable pressure water supplies by adding the optional retard chamber to the standard trim. The valve is available with a flanged inlet and flanged outlet, with a flanged inlet and grooved outlet, or with a grooved inlet and grooved outlet.

2. Model J-1 Alarm Check Valve Operation

The Model J-1 Alarm Check Valve is manufactured with a hinged clapper equipped with a torsion spring to assure proper operation when the valve is installed in the horizontal position. Minor flows, resulting from small surges, travel around the clapper through external by-pass trim (Figure 12) to minimize false alarms. Rubber gasket forms a tight seal against brass water seat. This seal, and the check valve installed in the external by-pass trim, serve to trap higher pressurized water in the sprinkler piping and prevent reverse flow.

During a sustained flow of water, such as the flow required by an open sprinkler, hinged clapper moves off seat to the open position. Water flows through orifices in grooved seat, and enters the alarm port (Figure 13) to activate alarm devices connected to the system.

Model J-1 Alarm Check Valve Operation with Retard Chamber:

When the optional retarding chamber is used, water entering the grooved seat alarm port is directed into the retarding chamber. Temporary pressure surges or fluctuations, large enough to move the valve clapper, are automatically drained through the restricted drain.

VIKING[®] **TECHNICAL DATA** **WET PIPE SPRINKLER SYSTEM**

The Viking Corporation, 210 N Industrial Park Drive, Hastings MI 49058
Telephone: 269-945-9501 Technical Services 877-384-5464 Fax: 269-818-1680 Email: techsvcs@vikingcorp.com

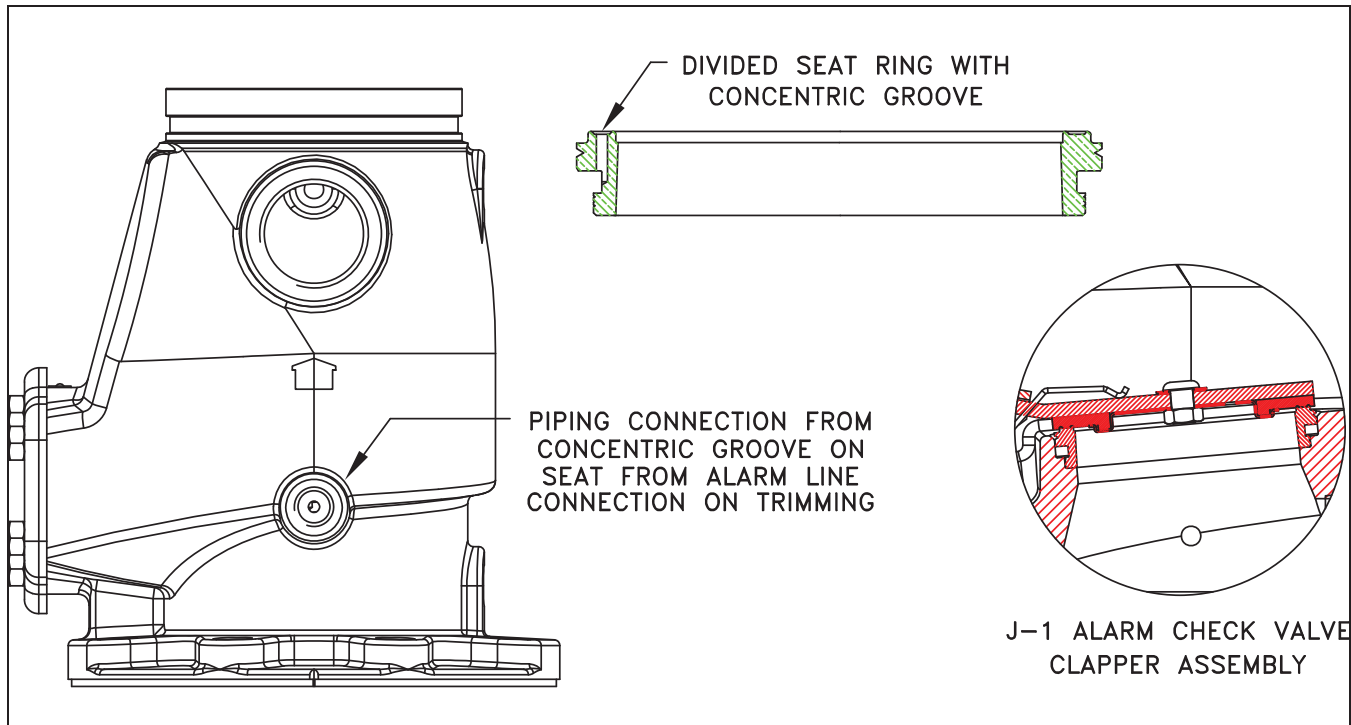

Figure 11

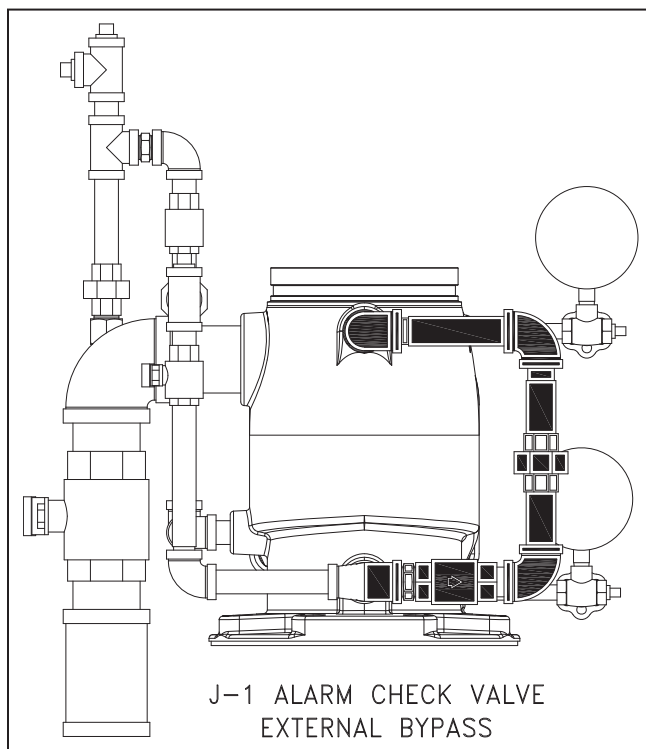

Figure 12

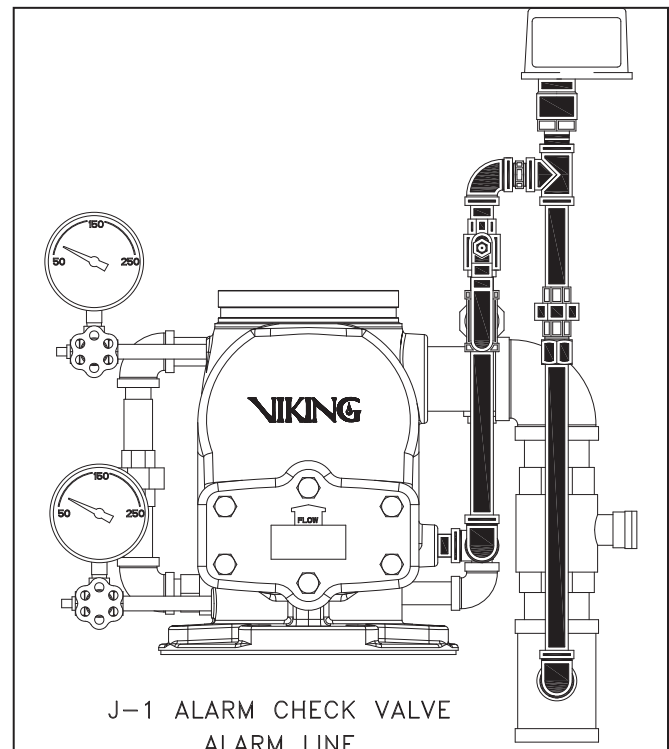

Figure 13

	TECHNICAL DATA	WET PIPE SPRINKLER SYSTEM
---	-----------------------	----------------------------------

The Viking Corporation, 210 N Industrial Park Drive, Hastings MI 49058
 Telephone: 269-945-9501 Technical Services 877-384-5464 Fax: 269-818-1680 Email: techsvcs@vikingcorp.com

During a sustained flow of water, such as the flow required by an open sprinkler, the clapper will be held off its seat. The retarding chamber will fill faster than water can drain through the restricted drain of the alarm valve trim. Alarm devices will be pressurized. Refer to technical data describing the Viking retarding chamber and alarm devices.

B. Model C-1 Retard Chamber (used with Model J-1 Alarm Check Valve)

1. Description

When the system is connected to a variable pressure source rather than a constant pressure source such as a city connection, a Viking Model C-1 Retard Chamber with appropriate trim is installed (Figures 15-18).

This 1-gallon capacity surge tank is used with Viking alarm check valves to absorb large surges and prevent false alarms.

2. Retard Chamber Operation

When the Model J-1 Alarm Check Valve opens, water flows out of the alarm port through the alarm line shut-off valve and into the inlet of the retard chamber (Figures 15-16).



Figure 14: Model C-1 Retard Chamber

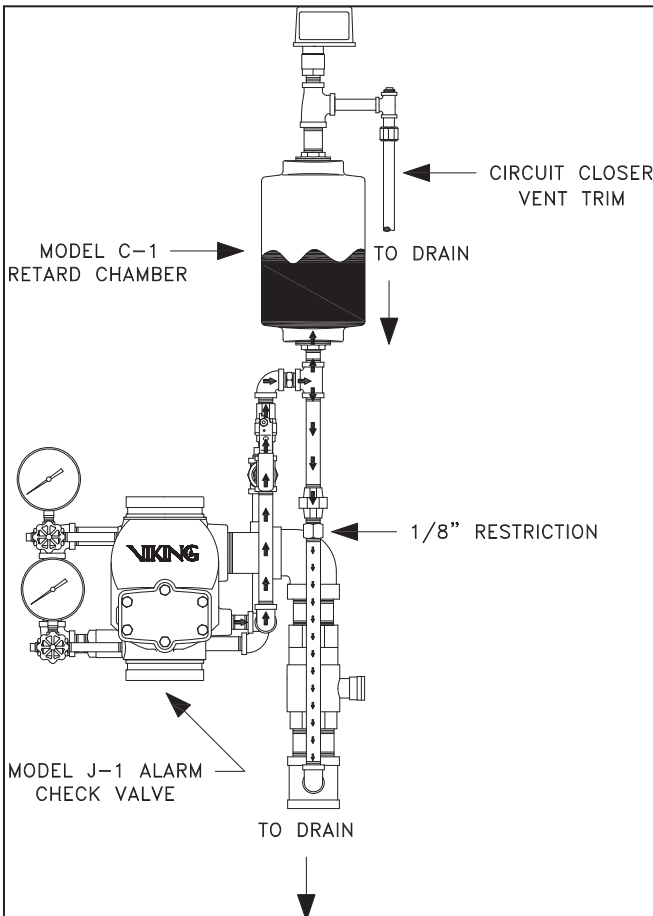

Figure 15

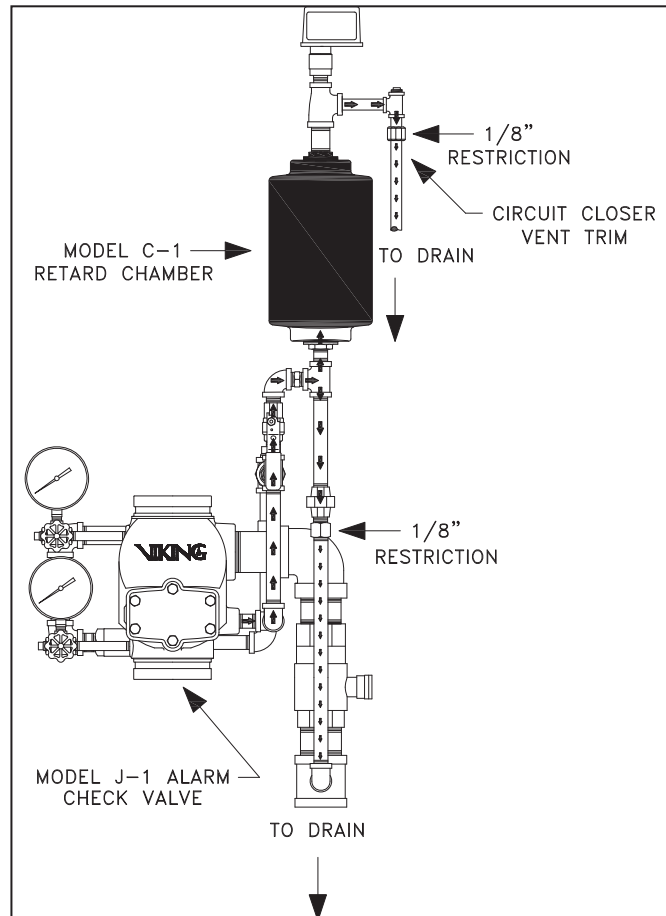

Figure 16

	TECHNICAL DATA	WET PIPE SPRINKLER SYSTEM
---	-----------------------	----------------------------------

The Viking Corporation, 210 N Industrial Park Drive, Hastings MI 49058
 Telephone: 269-945-9501 Technical Services 877-384-5464 Fax: 269-818-1680 Email: techsvcs@vikingcorp.com

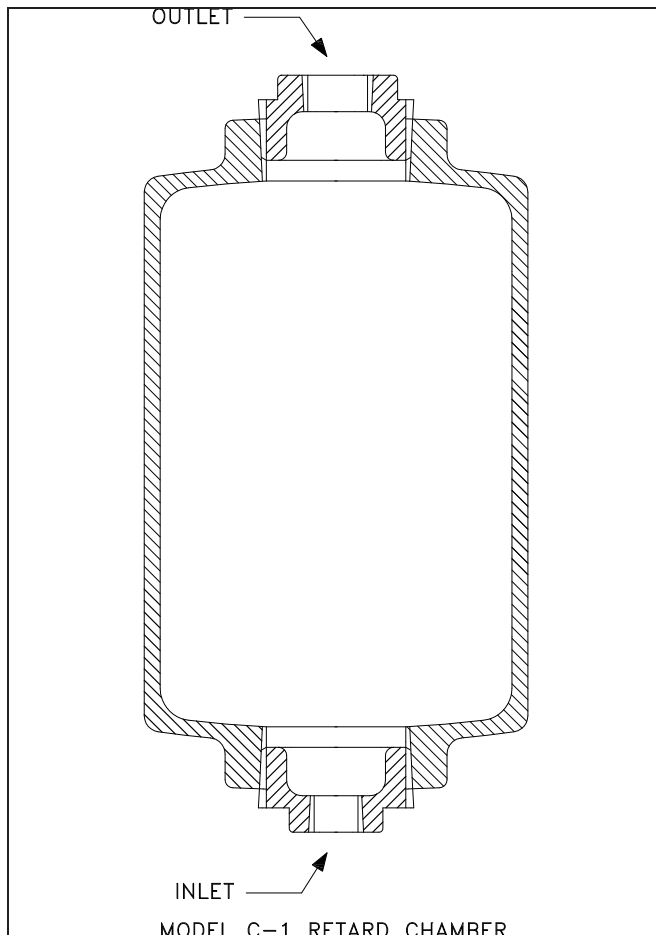

Figure 17

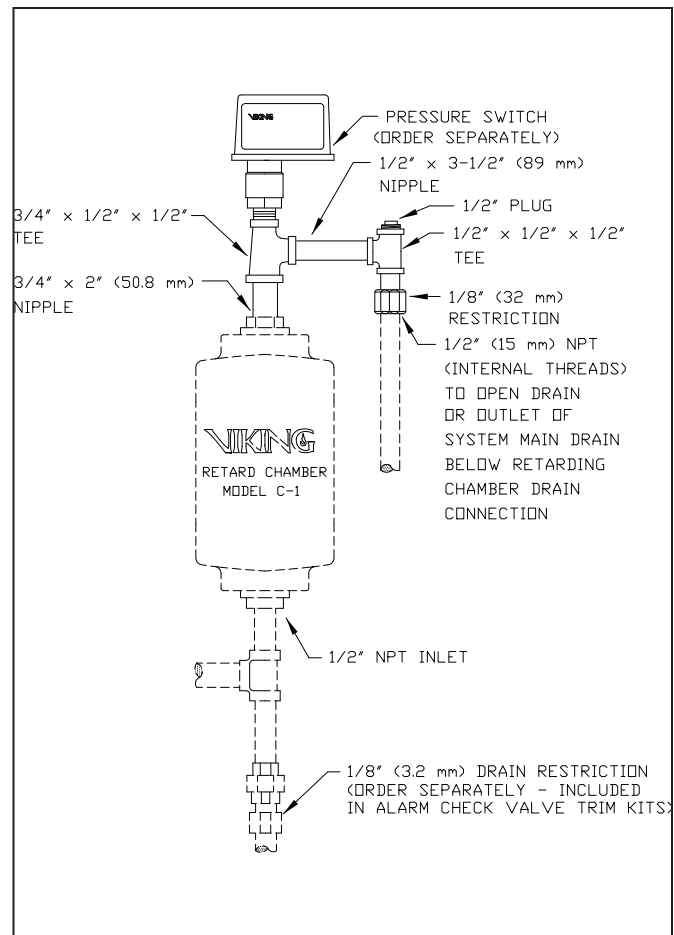

Figure 18: Circuit Closer Vent Trim

At the same time, water is being drained from the chamber through a 1/8" drain restriction. When the water flow through the chamber is sustained, the retard chamber will fill faster than it drains, allowing pressurized water to reach the alarm devices, which can be a water motor alarm, pressure switch, or both (Figure 19).

Pressure surges that are unable to overcome the volume and drain capacity of the retard chamber will not activate an alarm. Two retard chambers may be installed in series to combat false alarms from systems subject to excessive pressure surges.

After Installation and Prior to Each Waterflow Alarm Test:

1. Verify that the alarm check valve and retard chamber are trimmed exactly as shown on Viking trim sheets with no deviations. The trim size and arrangement is required for proper operation.
2. Inspect and clean the 1/8 inch (3.2 mm) drain restriction at least annually.

After Each Operation and Waterflow Alarm Test:

1. Verify that the retard chamber and alarm line piping has drained completely and associated alarm equipment has properly reset.
2. Refer to technical data for the water motor alarm, alarm pressure switch, and other associated equipment for additional testing and maintenance requirements.

VIKING® TECHNICAL DATA WET PIPE SPRINKLER SYSTEM

The Viking Corporation, 210 N Industrial Park Drive, Hastings MI 49058
 Telephone: 269-945-9501 Technical Services 877-384-5464 Fax: 269-818-1680 Email: techsvcs@vikingcorp.com

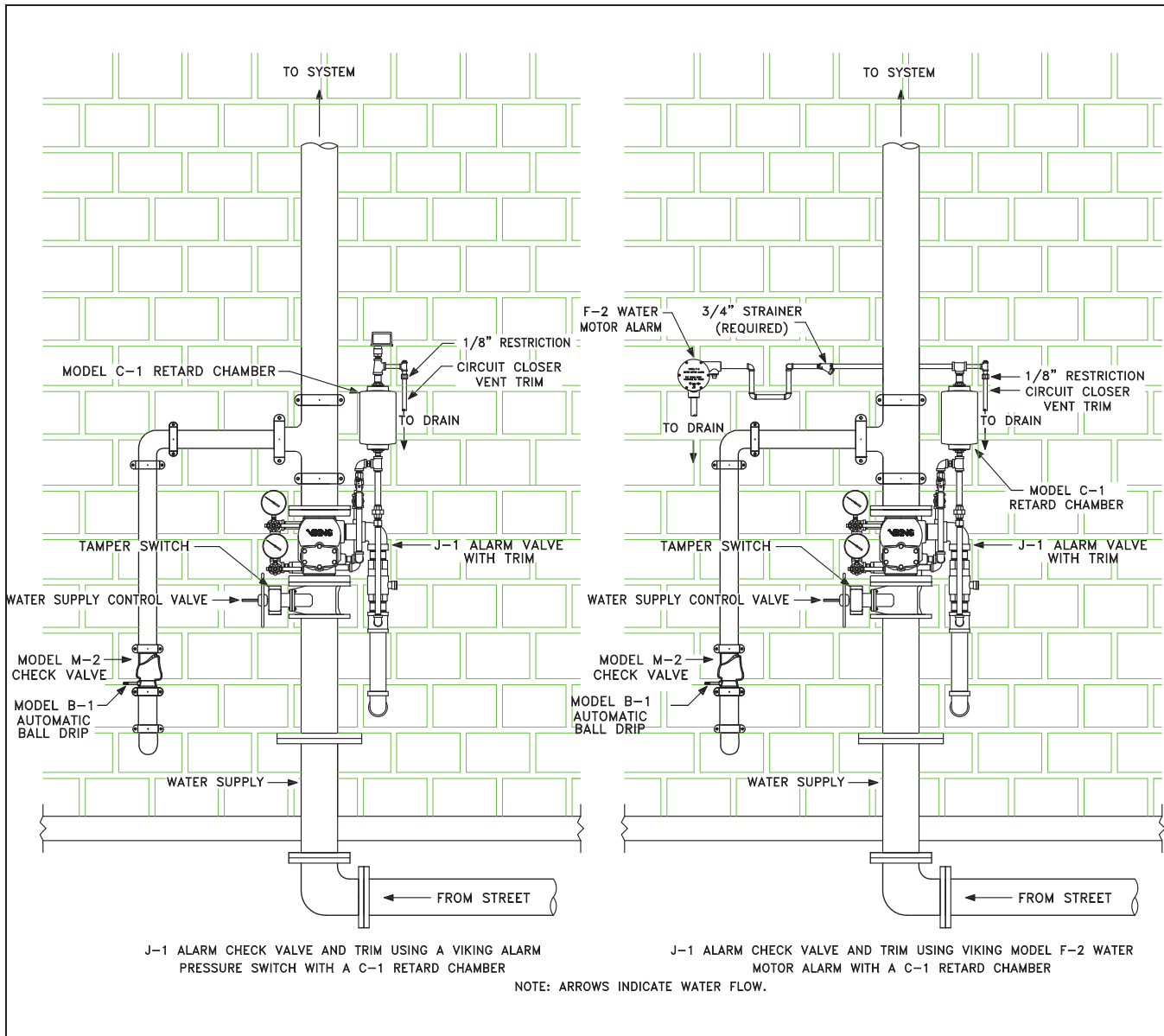

Figure 19

C. Water Motor Alarm (for use with the Model J-1 Alarm Check Valve)

Viking Water Motor Alarms (Figure 20) are mechanical devices actuated by a flow of water. They are designed to sound a continuous alarm while a sprinkler system operates. An alarm is a required component of every sprinkler system having more than 20 sprinklers.

1. Features and Accessories

- A. The water motor alarms are tapped 3/4" NPT on the inlet and 1" NPT on the drain outlet.



Figure 20: Water Motor Alarm



The Viking Corporation, 210 N Industrial Park Drive, Hastings MI 49058

Telephone: 269-945-9501 Technical Services 877-384-5464 Fax: 269-818-1680 Email: techsvcs@vikingcorp.com

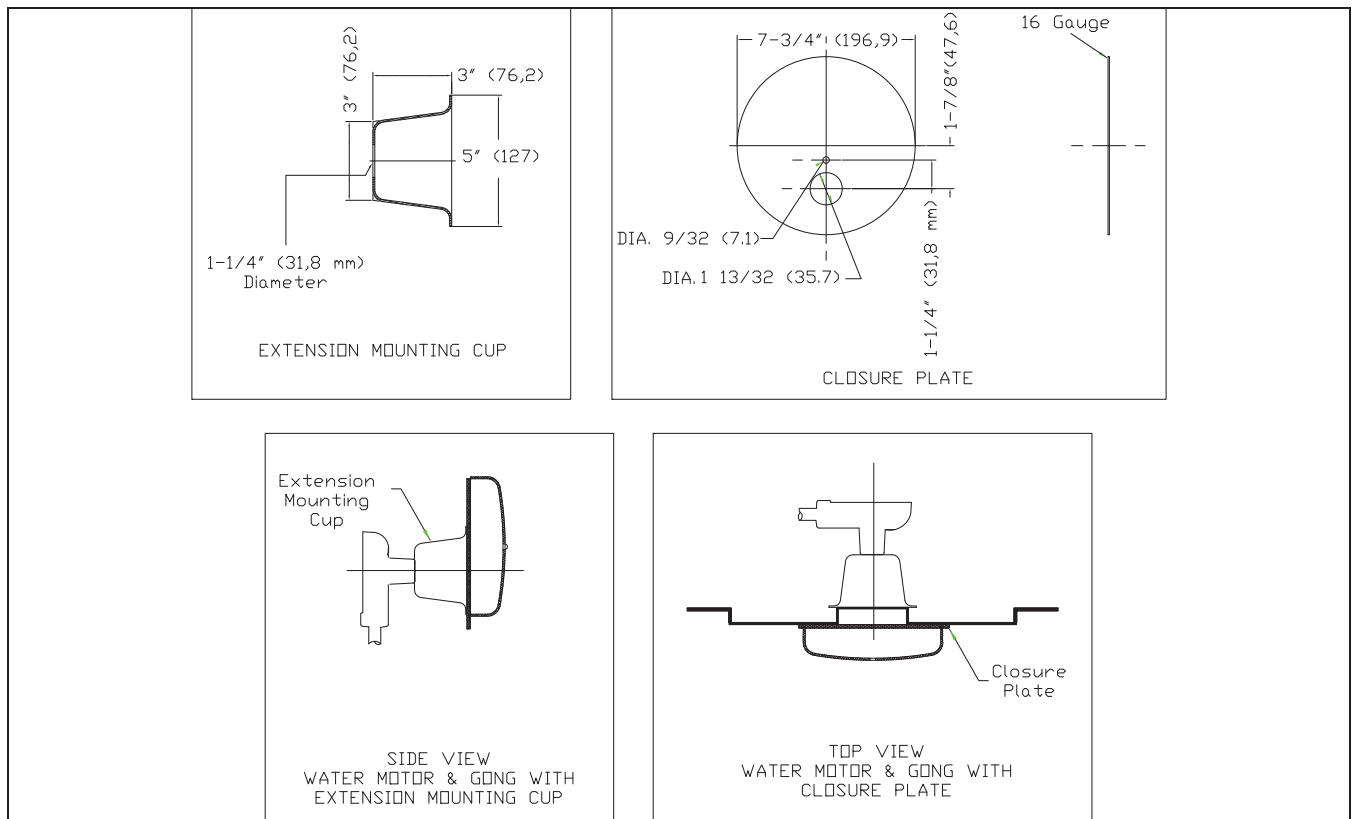

Figure 21

- B. The water motor alarm package includes a drive shaft 16-3/4" (425 mm) long for walls 14" (356 mm) thick or less. A special extension shaft is available for walls up to 30-1/4" (768 mm) thick.
- C. Also included is the required 3/4" (20 mm) NPT strainer for installation on the alarm line.
- D. Rated water working pressure of the Model F-2 Water Motor Alarm is 250 PSI (17.2 bar).

Accessories: (Figure 21)

1. Extension Mounting Cup: Viking Part Number 05957B, Material: 14-Gauge Cold Rolled Steel, UNS-G10080, coated with black E-coat. The extension mounting cup is required when the wall thickness is less than 3" (76.2 mm). Refer to "INSTALLATION" instructions in technical data page 711a-d.
2. Closure Plate: For use with Model F-2 Water Motor Alarm only, Viking Part Number 05820B, Material: 16-Gauge Galvanized Steel, UNS-G10080. The closure plate is required when the Model F-2 Water Motor Alarm gong is mounted on an irregularly surfaced wall. It serves to prevent birds from entering the inside of the gong. The closure plate also serves as a mounting plate for sheet metal walls. Refer to "INSTALLATION" instructions.
3. Special Extension Shaft: Viking Part Number 03312B, Material: Stainless Steel, UNS-S30400. The extension shaft is required when the F-2 or G-2 Water Motor Alarm is installed on walls from 14" (356 mm) to 30-1/4" (768 mm) thick.

2. Water Motor Alarm Operation

When a sprinkler system is activated, water flows from the alarm outlet of the valve, through the 3/4" (20 mm) strainer and alarm line piping, into the inlet of the water motor. From the 1/8" inlet orifice, the water flows through a nozzle, which restricts the flow into a pressurized stream directed onto the impeller. Force from the water stream turns the impeller and drive shaft, causing the striker arm to rotate. The striker impacts against the gong, producing a continuous alarm.

	TECHNICAL DATA	WET PIPE SPRINKLER SYSTEM
---	-----------------------	----------------------------------

The Viking Corporation, 210 N Industrial Park Drive, Hastings MI 49058

Telephone: 269-945-9501 Technical Services 877-384-5464 Fax: 269-818-1680 Email: techsvcs@vikingcorp.com

A minimum of 5 PSI (.34 bar) is required at the nozzle to cause a continuous alarm. When properly installed, the Model F-2 Water Motor Alarm produces the required 90 decibel output and the Model G-2 produces 100 decibels. After passing through the water motor, the water is discharged through a 1" (25 mm) drain outlet in the bottom of the impeller housing. The discharged water must be piped through the wall to atmosphere or to a suitable open drain.

3. Water Motor Alarm Maintenance

Weather-resistant materials are used in the construction of the water motor alarm. At regular intervals, examine and test the water motor to ensure that the nozzle and drain line are clean and free of obstruction, and that the alarm functions properly. Also, at regular intervals and before disassembly of the water motor, clean and inspect the alarm line strainer located at the alarm outlet of the waterflow detecting device, or the outlet of the retard chamber, if used.

(Note: Some retard chambers may be equipped with a strainer built in). Before proceeding with disassembly of the water motor alarm, notify the Authority Having Jurisdiction and occupants of the area covered by the system affected. Take all appropriate precautions. The water motor alarm will be disabled during disassembly.

A. Water Motor Disassembly:

1. Isolate the water motor alarm by closing the alarm line valve in the trim of the waterflow detecting device. (Refer to appropriate technical data for the system used).
2. Remove pipe plug.
3. Remove all round head machine screws from the water motor cover.
4. Separate the cover and the gasket from the housing.
5. Remove the impeller.
6. Inspect and, if necessary, carefully clean the nozzle with a wire or pipe cleaner brush.
7. Flush the nozzle way and drain line with water or compressed air.

B. Water Motor Re-Assembly:

1. Re-install the pipe plug.
2. Re-install the impeller.
3. Replace cover gasket and attach cover by using round head machine screws.
4. Open the alarm line valve.
5. Test the water motor alarm (Refer to Figure 21 for the alarm test line).
6. When test is complete and water motor alarm operation is satisfactory, place the alarm line valve in the proper "alarm" position. Reset and return the affected systems to service.

D. Fire Department Check Valves

Viking Check Valves (Figures 22-23) are general purpose rubber-faced check valves approved for use in fire protection systems. The Model D-1 and G-1 Swing Check Valves are manufactured with a ductile iron body, brass seat, and a rubber-faced clapper assembly, hinged to a removable access cover for easy inspection and maintenance. The Model M-2 Check Valve (patent pending) is manufactured with a ductile iron body, a stainless steel clapper assembly, brass seat, and an EPDM rubber.



Figure 22: Model D-1 or G-1 Swing Check Valve



Figure 23: Model M-2 Check Valve

	TECHNICAL DATA	WET PIPE SPRINKLER SYSTEM
---	-----------------------	----------------------------------

The Viking Corporation, 210 N Industrial Park Drive, Hastings MI 49058
 Telephone: 269-945-9501 Technical Services 877-384-5464 Fax: 269-818-1680 Email: techsvcs@vikingcorp.com

These check valves may be installed in the vertical position with direction of flow up, or in the horizontal position (with the access cover up for Models D-1 and G-1, or with the 1/2" drain boss down that includes a test orifice with size specified per order from 3/8" K2.8 – ESFR K14 (note ESFR (not available in 1-1/4 – 2" riser pacs) depending on the smallest sprinkler installed on the system on the Model M-2 Check Valve).

V. OPTIONAL EQUIPMENT
- EasyPac Riser Manifold Assemblies

1. Description

Viking EasyPac Riser Assemblies (Figure 24) are prepackaged riser manifold assemblies available in various configurations and sizes for commercial or residential use, or for high rise buildings requiring floor control assemblies. All EasyPac assemblies are factory assembled and pressure tested and meet the requirements of NFPA13, or NFPA 13D and NFPA 13R system standards.

EasyPac Riser Assemblies are designed with all required equipment and standard components that can be replaced in the field, including UL Listed and FM Approved pressure gauges, Potter flow switches, 3-way gauge control valve and appropriate drain valve.

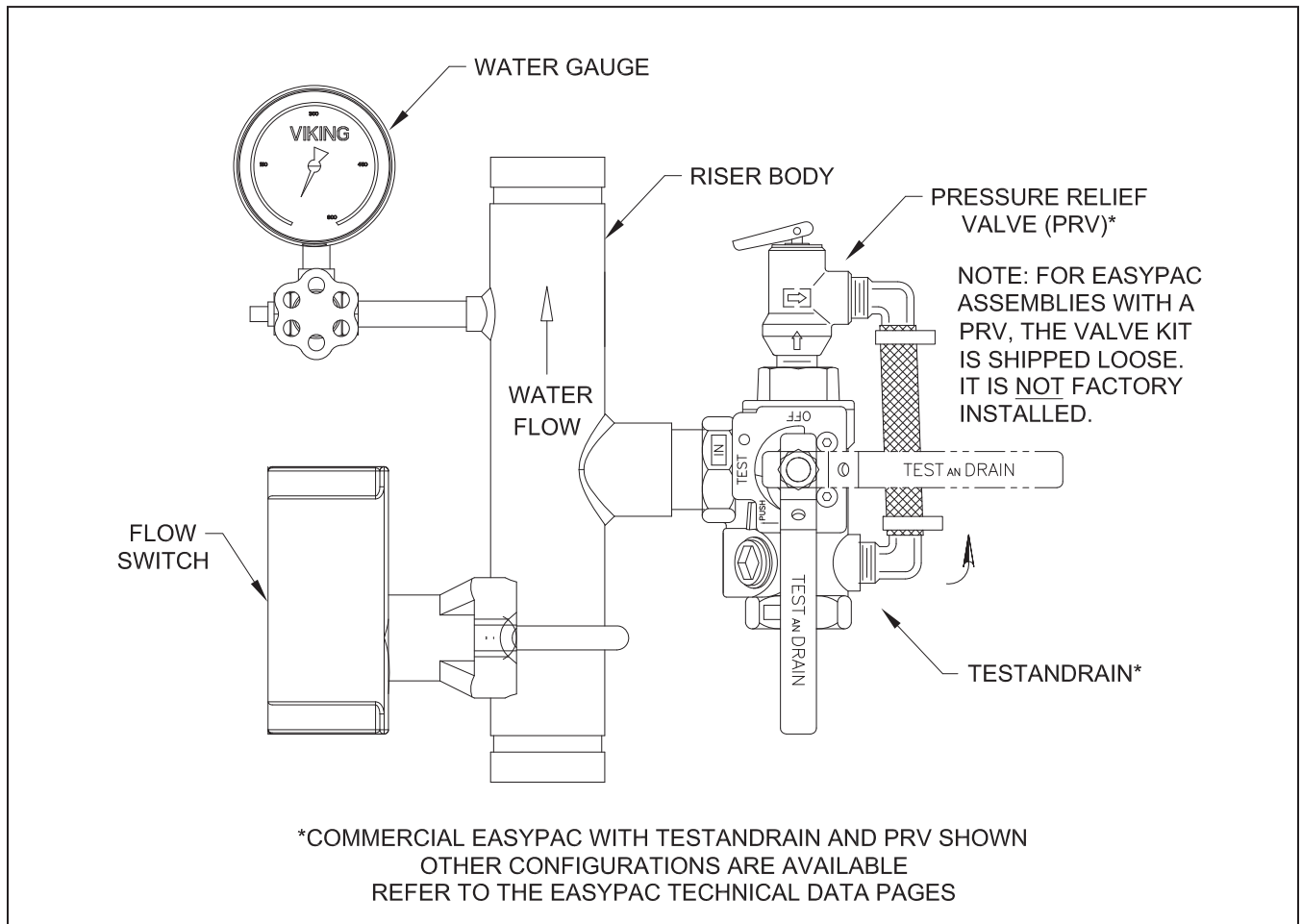

Figure 24: Viking EasyPac Riser Assembly

	TECHNICAL DATA	WET PIPE SPRINKLER SYSTEM
---	-----------------------	----------------------------------

The Viking Corporation, 210 N Industrial Park Drive, Hastings MI 49058

Telephone: 269-945-9501 Technical Services 877-384-5464 Fax: 269-818-1680 Email: techsvcs@vikingcorp.com

There are three different configurations for commercial, residential, and floor control assemblies:

1. Basic riser assembly with ball valve
2. Riser assembly with TESTanDRAIN valve that includes a test orifice with size specified from 3/8" (K2.8) to K25 ESFR, depending on the smallest sprinkler installed on the system. (Note ESFR not available in 1-1/4 – 2" risers.)
3. Riser assembly with TESTanDRAIN and pressure relief valve (PRV), with pressure setting specified from 175 to 250 PSI. (Note the pressure rating of the relief valve indicates an operating range of pressure for both opening and closing of the valve. Standard relief valves are required to OPEN in a range of pressure between 90% and 105% of their rating. The valves are required to CLOSE at a pressure above 80% of that rating.)

EasyPac riser assemblies with an AGF TESTanDRAIN valve, and/or pressure relief valve (PRV) meet NFPA 13 requirements for gridded systems and any system requiring a pressure relief valve. This configuration eliminates the need to drain the system before installing the relief valve, while a built in test port allows hydrostatic testing without draining the system. Refer to the EasyPac technical data pages for details on the various design configurations.

Note: EasyPac Riser Manifold Assemblies can be installed horizontally with flow switch on top, or vertically with flow upward.

Each flow switch can be wired for open or closed circuit operation. See Figure 30 on page 21.

2. TESTanDrain Valve Operation

To Test: Turn valve handle counterclockwise from "Off" to "Test". The handle will stop automatically. After test is completed, return handle to "Off".

To Drain: Turn handle counterclockwise from "Off" to "Test". The handle will stop automatically. Depress "Push" button and turn handle to "Drain". When system is empty, return handle clockwise to "Off" position.

VI. WATER FLOW ALARM EQUIPMENT

A. Alarm Pressure Switch

1. Description

Viking Alarm Pressure Switches are electric alarm initiating devices designed to activate alarms when the sprinkler system operates. The switch may also initiate signals to annunciator panels, trip municipal fire alarm boxes, signal fire pump start-up, or any other function that can be initiated or controlled by the opening or closing of an electrical switch. The switch can be wired for normally open and/or normally closed operation.

Two models are available. The first is equipped with one single-pole double-throw (SPDT) snap action switch; the other with dual SPDT snap action switches. Both models are equipped with 1/2" (15 mm) NPT pressure connections manufactured from brass to ensure mechanical strength and endurance.

2. Alarm Pressure Switch Installation

WARNING: The alarm pressure switches (Figure 25) described in this manual are general service switches, not designed for use in explosive atmospheres. Refer to the technical data page for the Explosion-Proof/Watertight Alarm Pressure Switch intended for use in those environments.



Figure 25: Alarm Pressure Switch

	<h2 style="margin: 0;">TECHNICAL DATA</h2>	<h2 style="margin: 0;">WET PIPE SPRINKLER SYSTEM</h2>
---	--	---

The Viking Corporation, 210 N Industrial Park Drive, Hastings MI 49058
 Telephone: 269-945-9501 Technical Services 877-384-5464 Fax: 269-818-1680 Email: techsvcs@vikingcorp.com

1. Refer to the current Viking trim chart for the valve used to determine the appropriate location for installing the Viking Alarm Pressure Switch on Viking trim. Viking trim sets provide:
 - a. An alarm connection, equipped with an alarm test valve, and an alarm shut-off valve for switches used for local alarms and,
 - b. A non-interruptible alarm connection, equipped with an alarm test valve, for switches used to signal electric alarm panels and remote alarms.

CAUTION: Closing any shut-off valve in the alarm piping leading to the alarm pressure switch will render the switch inoperative.

2. When installing the general service alarm pressure switch, apply Teflon® tape sealant to the male threads only (Figure 26). Install the pressure switch in a 1/2" (15 mm) pipe fitting. Use a wrench applied to the wrench flats to tighten the unit. Do not over-tighten.
 - a. Mount the alarm pressure switch in the upright position (threaded connection down).
3. To wire the unit proceed as follows:
 - a. De-energize electrical circuits involved.
 - b. Use the special wrench, supplied with the switch, to loosen and remove the tamper-resistant screws. Remove cover. Use care not to lose the rubber O-ring screw retainers.

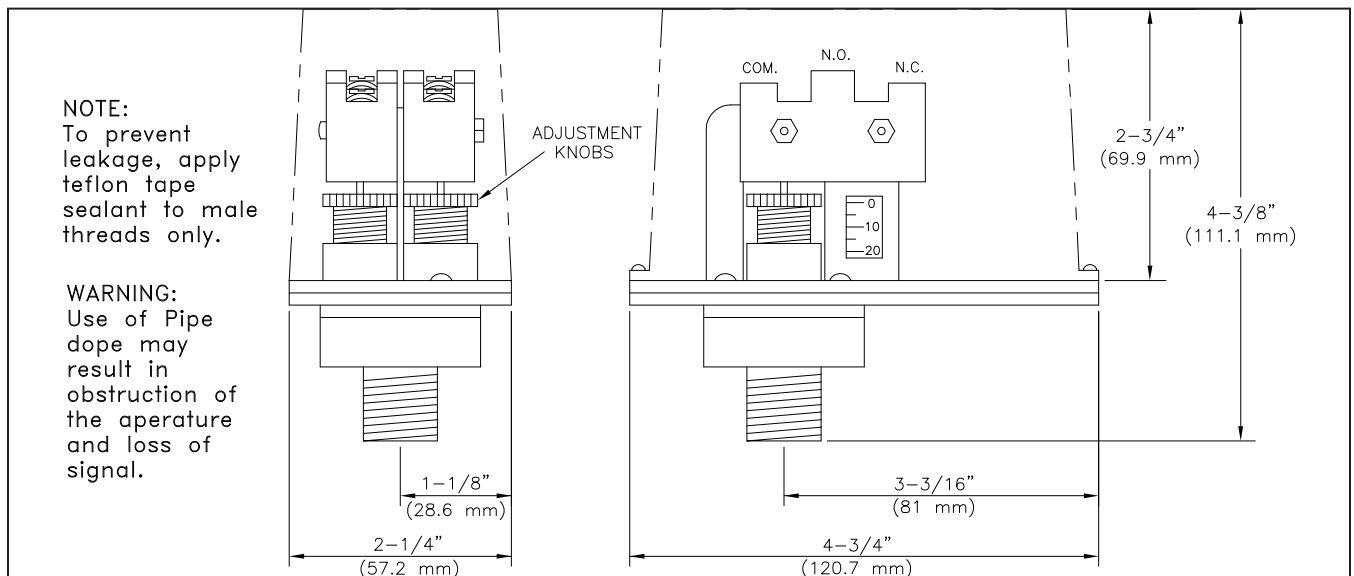

Figure 26

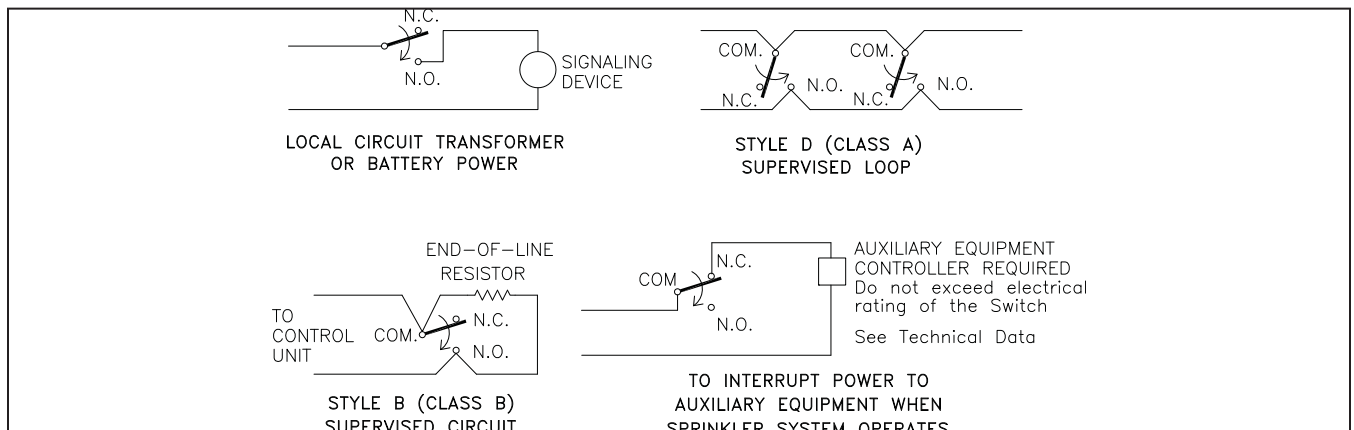

Figure 27

	TECHNICAL DATA	WET PIPE SPRINKLER SYSTEM
---	-----------------------	----------------------------------

The Viking Corporation, 210 N Industrial Park Drive, Hastings MI 49058
 Telephone: 269-945-9501 Technical Services 877-384-5464 Fax: 269-818-1680 Email: techsvcs@vikingcorp.com

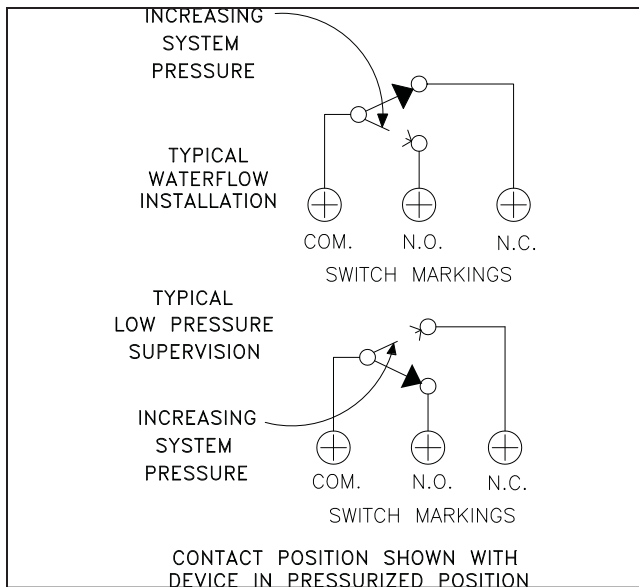

Figure 28

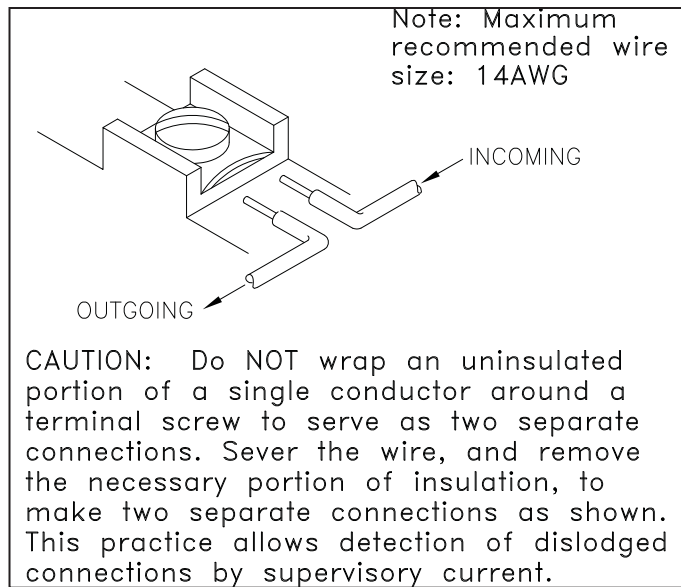

Figure 29

- c. Connect conduit to the conduit opening provided. Refer to technical data page for the alarm pressure switch.
- d. Connect electrical circuitry for the alarm and any auxiliary equipment being controlled by the switch. (Refer to Figures 27-29).

Note: Wire all devices to national and local codes and requirements of the Authority Having Jurisdiction.

4. Replace cover and tighten the tamper-resistant screws.
5. Energize the circuits.
6. Test for proper operation of the device. See section INSPECTION, TESTS AND MAINTENANCE in the technical data page for the alarm pressure switch.

B. Waterflow Indicator (for use with the Model E-1 Easy Riser® Check Valve)

1. Description

The Waterflow Indicator is a vane-type waterflow switch designed to detect a sustained flow of water exceeding 10 gpm. The Model VSR-F has a built-in adjustable pneumatic retard device delays actuation of the electrical switches to reduce the possibility of false alarms caused by one or more transient flow surges. The Model VS-SP does not have a retard to prevent false alarm, therefore, it should NOT be used on systems with variable water pressure, except in the case of elevator recall. The unit includes two single-pole double-throw snap action switches (Figure 30) used to operate local alarms, indicate signals to annunciator panels, trip

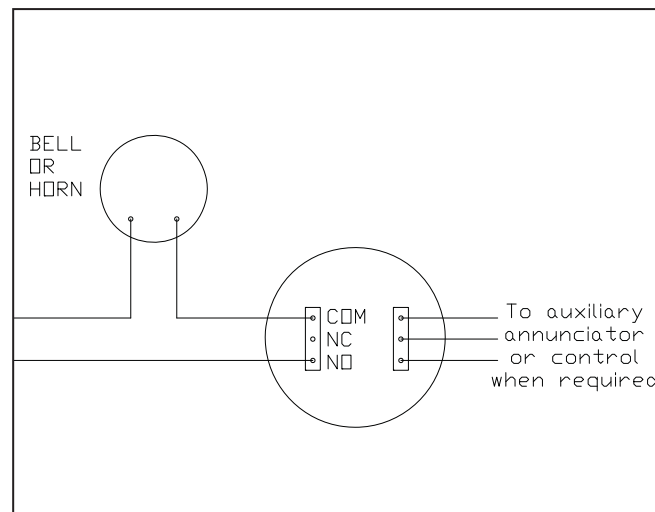

Figure 30: Waterflow Indicator with Two Single-Pole, Double Throw Micro Switches



TECHNICAL DATA

WET PIPE SPRINKLER SYSTEM

The Viking Corporation, 210 N Industrial Park Drive, Hastings MI 49058

Telephone: 269-945-9501 Technical Services 877-384-5464 Fax: 269-818-1680 Email: techsvcs@vikingcorp.com

municipal fire alarm boxes, start fire pumps, or any other function that can be initiated or controlled by the opening or closing of an electrical switch. The device may be installed on the main riser to give a system waterflow signal or on branch feed mains, cross mains, or branch lines to give a waterflow signal by zone or area. Note that a waterflow indicator is included with Viking EasyPac Riser Manifold Assemblies as shown in Figure 24 on page 17.

2. Operation

The waterflow indicator detects a flow of water exceeding 10 gpm in the piping when the flexible vane is deflected. This motion activates the field-adjustable pneumatic retard device. The pneumatic retard device delays activation of the electrical switches to reduce the possibility of false alarms caused by a single or series of transient flow surges. The retard device instantly resets during a series of surges to prevent a cumulative effect. After a sustained flow, the two switches operate to open or close electrical contacts.

Repairs: Any waterflow indicator requiring repairs due to damaged components should be replaced with a new unit. Refer to installation instructions for adjustments.

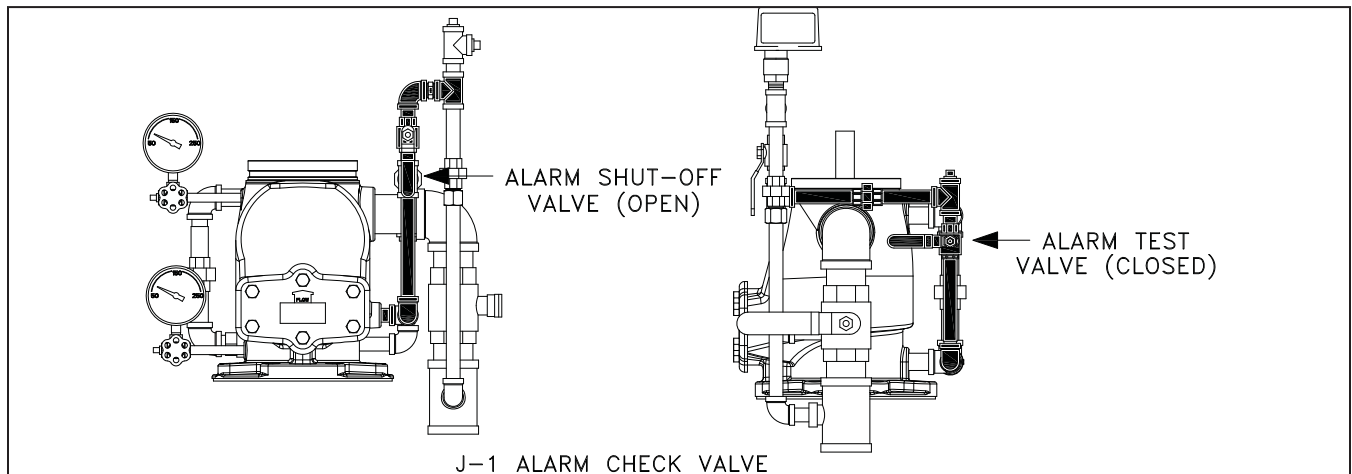

Figure 31

VII. WET SYSTEM NORMAL CONDITIONS

1. All water supply control valves open and secured.
2. The alarm shut-off valve in the alarm check valve trim is open (Figure 31), and the alarm test valve is closed (for systems using the Model J-1 Alarm Check Valve with a mechanical alarm).
3. Water gauge valves open (Figure 32).
4. The water supply pressure gauge (lower gauge) equals that of the known service-line pressure. The system pressure gauge (upper gauge) reading is equal to or greater than the water supply pressure gauge reading.
5. Incoming power to all alarm switches on.
6. Main-drain valve, auxiliary drain valves and inspectors test valves are tightly closed (Figure 33).

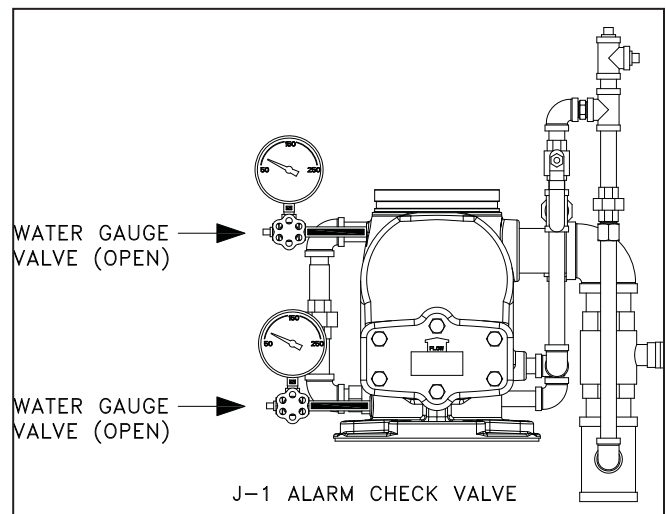

Figure 32



TECHNICAL DATA

WET PIPE SPRINKLER SYSTEM

The Viking Corporation, 210 N Industrial Park Drive, Hastings MI 49058

Telephone: 269-945-9501 Technical Services 877-384-5464 Fax: 269-818-1680 Email: techsvcs@vikingcorp.com

7. The sprinkler head cabinet contains appropriate replacement sprinklers and wrenches.
8. Temperature maintained above 40 °F (4 °C) for the entire system.
9. If a fire department connection is used, make sure the automatic drip valve is free, allowing accumulated water to escape (Figure 34).

VIII. WET SYSTEM OPERATION

In the normal set condition, the system piping is filled with water. When a fire occurs, the heat operates a sprinkler, allowing the water to flow.

- A. Where the Model J-1 Alarm Check Valve is used, the alarm valve clapper is opened by the flow of water allowing water to enter the alarm port to activate the alarm devices. When using variable pressure water supply, the water flowing through the alarm port overcomes the retard chamber's drain restriction, filling the retard chamber, then activating the connected alarm devices.
- B. Where the Model E-1 Easy Riser® Swing Check Valve is used, flow of water activates the waterflow switch. The paddle, which normally lies motionless inside the pipe, is forced up, thereby activating the pneumatic time delay mechanism which closes or opens a micro-switch after the preset retard time has elapsed.

This action causes an electric alarm to sound. All alarms will continue to sound as long as there is a flow of water in the system. The alarms will continue to sound until the flow of water is manually turned off.

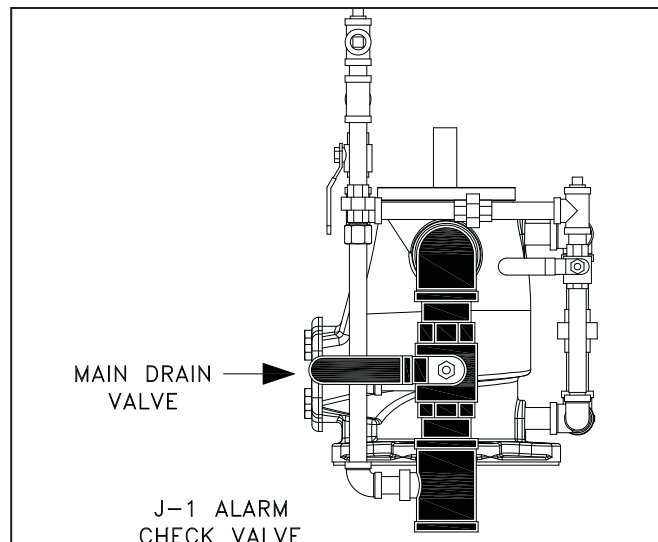

Figure 33

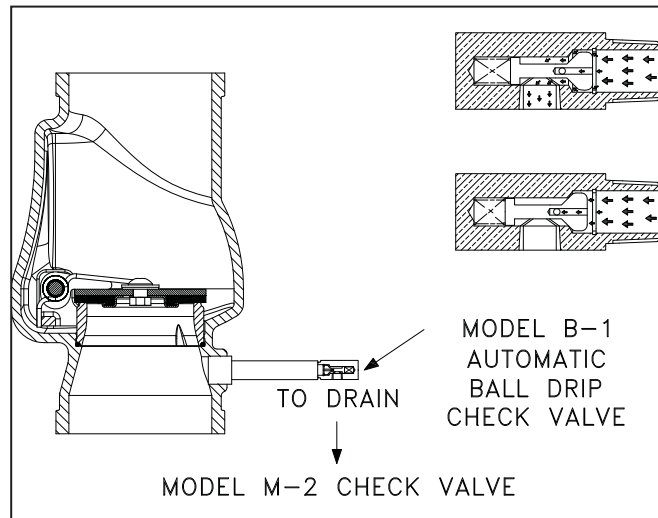

Figure 34

IX. WET SYSTEM INSPECTIONS, TESTS, AND MAINTENANCE

NOTICE: THE OWNER IS RESPONSIBLE FOR MAINTAINING THE FIRE-PROTECTION SYSTEM AND DEVICES IN PROPER OPERATING CONDITION.

WARNING: ANY SYSTEM MAINTENANCE THAT INVOLVES PLACING A CONTROL VALVE OR DETECTION SYSTEM OUT OF SERVICE MAY ELIMINATE THE FIRE-PROTECTION CAPABILITIES OF THAT SYSTEM. PRIOR TO PROCEEDING, NOTIFY ALL THE AUTHORITY HAVING JURISDICTION. CONSIDERATION SHOULD BE GIVEN TO EMPLOYMENT OF A FIRE PATROL IN THE AFFECTED AREAS.

It is imperative that the system be inspected and tested on a regular basis in accordance with NFPA 25. During all inspections, testing, and maintenance activities the valve, trim, piping, alarm devices, and connected equipment must be visually inspected for foreign matter, physical damage, freezing, corrosion, or other conditions that may inhibit the proper operation of the system.



TECHNICAL DATA

WET PIPE SPRINKLER SYSTEM

The Viking Corporation, 210 N Industrial Park Drive, Hastings MI 49058

Telephone: 269-945-9501 Technical Services 877-384-5464 Fax: 269-818-1680 Email: techsvcs@vikingcorp.com

The following recommendations are minimum requirements. The frequency of the inspections may vary due to contaminated or corrosive water supplies and corrosive atmospheres. In addition, the alarm devices or other connected equipment may require more frequent inspections. Refer to the system description, sections in this manual specifically for each component of the system, applicable codes, and the authority having jurisdiction for minimum requirements. Prior to testing the equipment, notify appropriate personnel.

Monthly visual external inspection is recommended.

1. Verify that pressure gauges indicate normal water supply pressures. It is normal for the gauge on the system side of the clapper to register a higher pressure than the gauge on the supply side of the clapper because pressure surges are trapped above the clapper.
2. Check for signs of mechanical damage and/or corrosive activity. If detected, perform maintenance as required or, if necessary, replace the device.
3. Verify that valve and trim are adequately heated and protected from freezing and physical damage.
4. When equipped with variable pressure trim, verify that there is no unwanted leakage from the restricted drain of the retard chamber. It is normal for drainage to occur during pressure surges that exceed the capacity allowed through the by-pass trim.
5. Verify that the water supply main control valve is open, and that all valves are in their normal operating position and appropriately secured.

A. Waterflow Alarm Test

Quarterly testing of water flow alarms is recommended and may be required by the Authority Having Jurisdiction and NFPA 25. Section 8.17.4.2 of NFPA 13-2007 edition, requires an alarm test connection at least 1" (25 mm) diameter, with flow equivalent to one sprinkler (or less) having the smallest orifice on the system. The test connection may be installed in anywhere downstream of the waterflow alarm, however, it must be readily accessible. It must discharge to the outside, to a drain connection capable of accepting full flow under system pressure, or to another location where water damage will not result. Section 5.3.3 of NFPA 25-2008 edition requires testing all connected alarm devices by opening the system test valve.

1. Notify the Authority Having Jurisdiction, remote station alarm monitors, and those in the area affected by the test.

NOTE: AN ALARM SHUT-OFF VALVE IS PROVIDED TO SILENCE LOCAL ALARMS. NO SHUT-OFF VALVE IS PROVIDED FOR THE PRESSURE SWITCH CONNECTION INTENDED TO ACTIVATE ELECTRIC ALARM PANELS. (REFER TO J-1 ALARM CHECK VALVE TRIM CHART.)

2. To test electric alarms (if provided) and/or mechanical water motor gong (if provided), OPEN the system test valve (Figure 35).

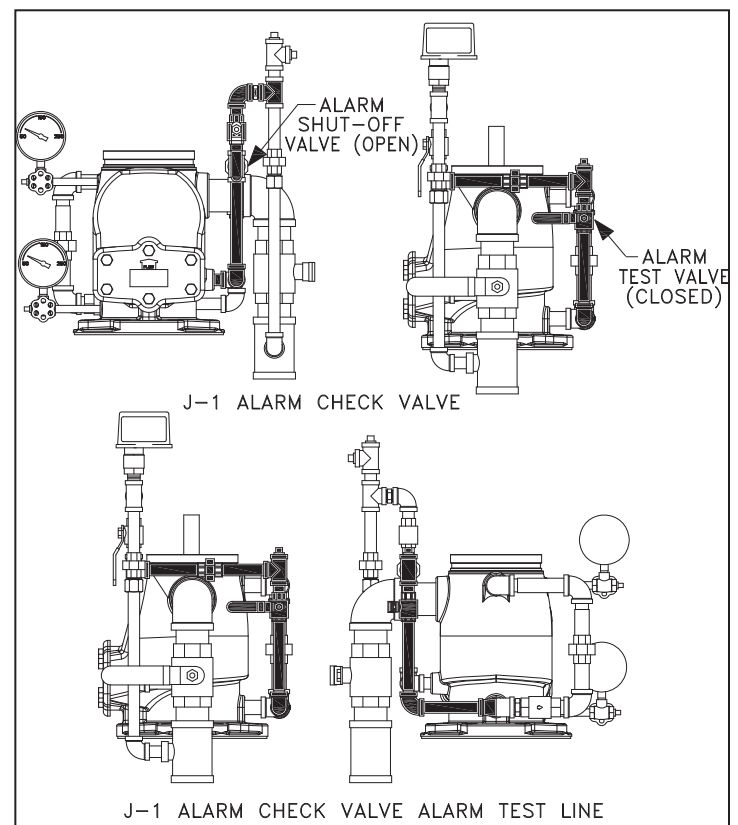

Figure 35



TECHNICAL DATA

WET PIPE SPRINKLER SYSTEM

The Viking Corporation, 210 N Industrial Park Drive, Hastings MI 49058

Telephone: 269-945-9501 Technical Services 877-384-5464 Fax: 269-818-1680 Email: techsvcs@vikingcorp.com

If freezing weather or other conditions prohibit use of the system test valve, OPEN the alarm test valve (Figure 36) in the alarm check valve trim.

NOTE: USE OF THE ALARM TEST VALVE ALLOWS TESTING OF ALARMS WITHOUT REDUCING THE SYSTEM PRESSURE.

- a. Electric alarm pressure switches should activate.
- b. Electric local alarms should be audible.
- c. The local water motor alarm should be audible.

NOTE: WHEN USING THE SYSTEM TEST VALVE FOR THE WATER FLOW ALARM TEST, INTERMITTENT OPERATION OF THE WATER MOTOR ALARM MAY INDICATE AIR IS TRAPPED IN THE SYSTEM (REFER TO THE PLACING THE SYSTEM IN SERVICE).

- d. Verify that remote station alarm signals (if provided) were received.
3. When testing is complete, close the test valve used (Figure 37).
4. Verify:
 - a. All local alarms stop sounding and electric panels (if provided) reset.
 - b. All remote station alarms reset.
 - c. Retard chamber and water motor alarm supply piping has drained properly (if applicable).
5. For systems using the Model J-1 Alarm Check Valve, verify that the alarm shut-off valve in the alarm check valve trim is OPEN (Figure 38), the alarm test valve is CLOSED, and all valves are in their normal operating position and appropriately secured.
6. Notify the Authority Having Jurisdiction, remote station alarm monitors, and those in the affected area that testing is complete.

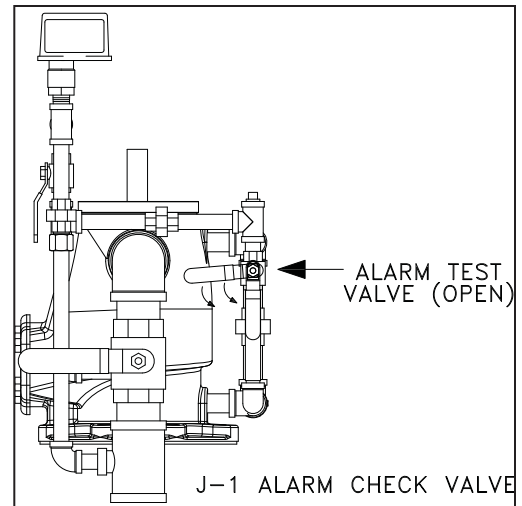

Figure 36

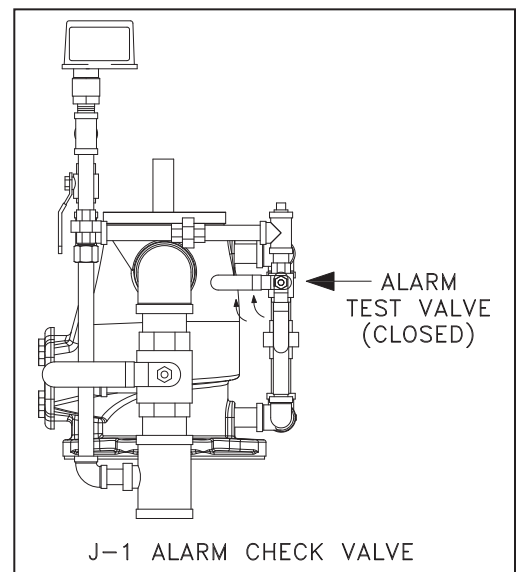

Figure 37

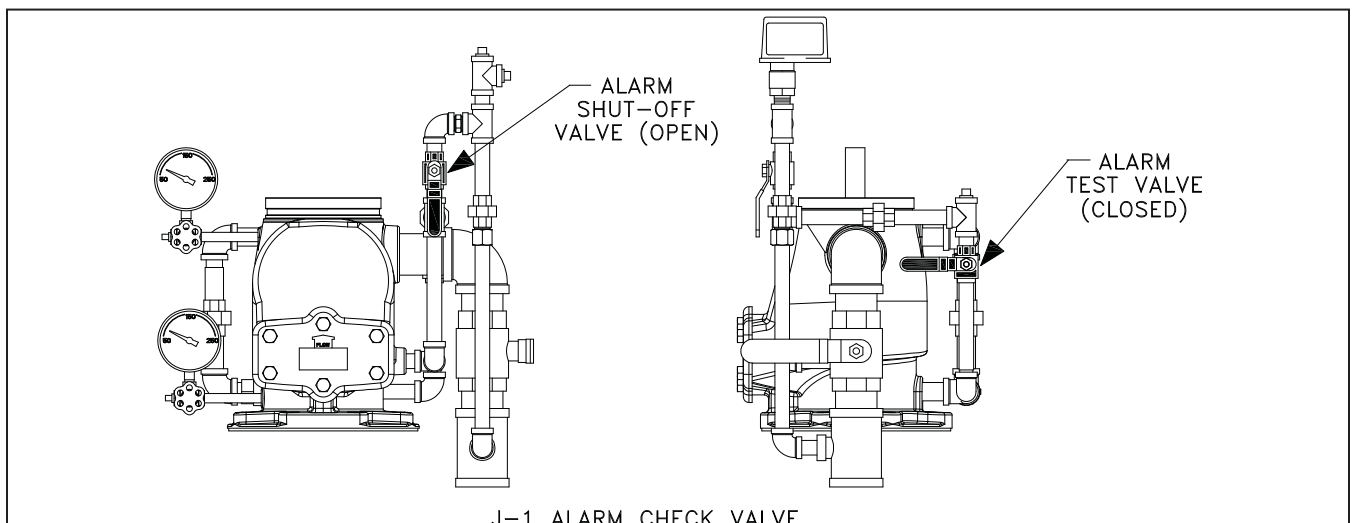

Figure 38



TECHNICAL DATA

WET PIPE SPRINKLER SYSTEM

The Viking Corporation, 210 N Industrial Park Drive, Hastings MI 49058
 Telephone: 269-945-9501 Technical Services 877-384-5464 Fax: 269-818-1680 Email: techsvcs@vikingcorp.com

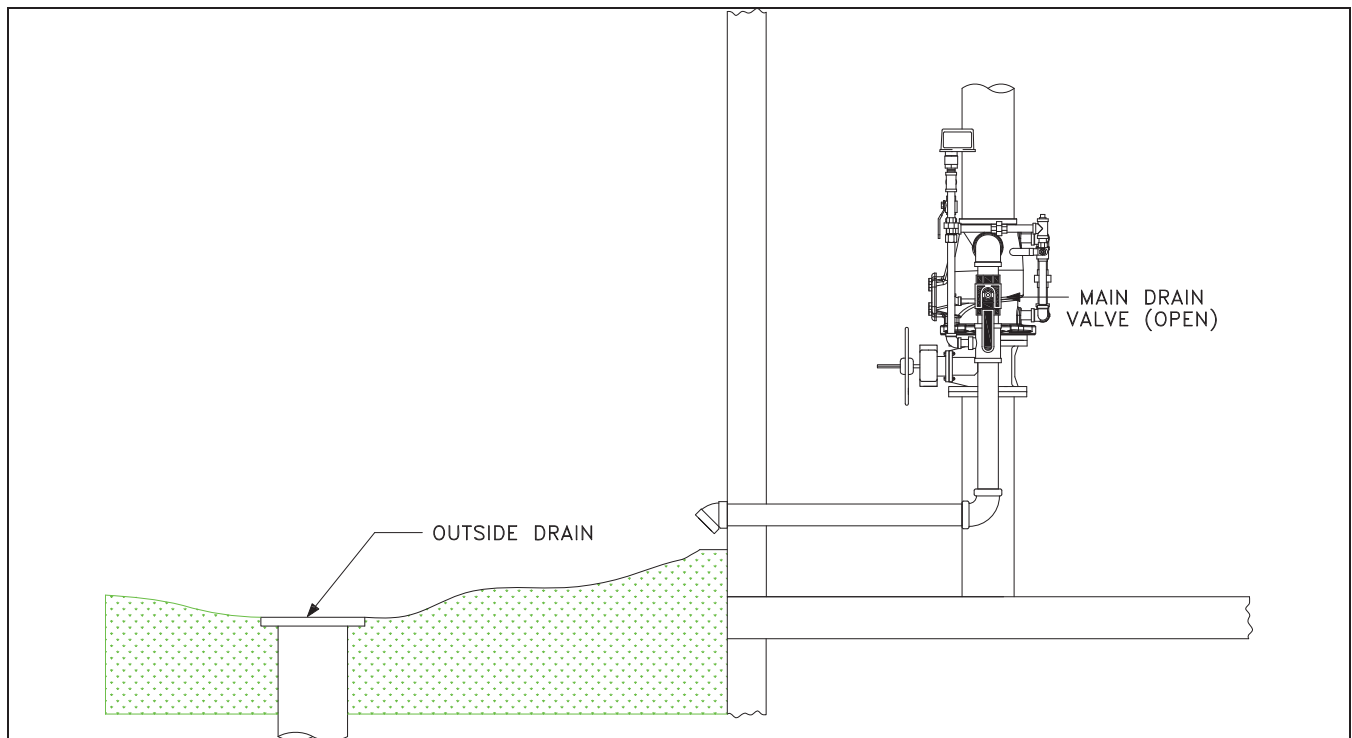

Figure 39

B. Main Drain Test

At least annually, each system riser is required to have a main drain test performed per section 13.2.5 of NFPA 25-2008 edition. A main drain test is conducted any time the control valve is closed and reopened on each system riser to determine if there has been a change in the water supply piping and control valves. Note: For systems where the water supply is through a backflow preventer and/or pressure reducing valves, the main drain test of at least one system downstream of the device shall be conducted on a quarterly basis.

1. Notify the Authority Having Jurisdiction, remote station alarm monitors, and those in the area affected by the test.
2. Perform monthly visual inspection.
3. Verify that adequate drainage is provided for full flow from the main drain outlet (Figure 39).
4. Record pressure reading from the water supply pressure gauge (Figure 40).
5. Fully OPEN the main drain. (For systems with a mechanical alarm, the alarm (Figure 41) should sound.)

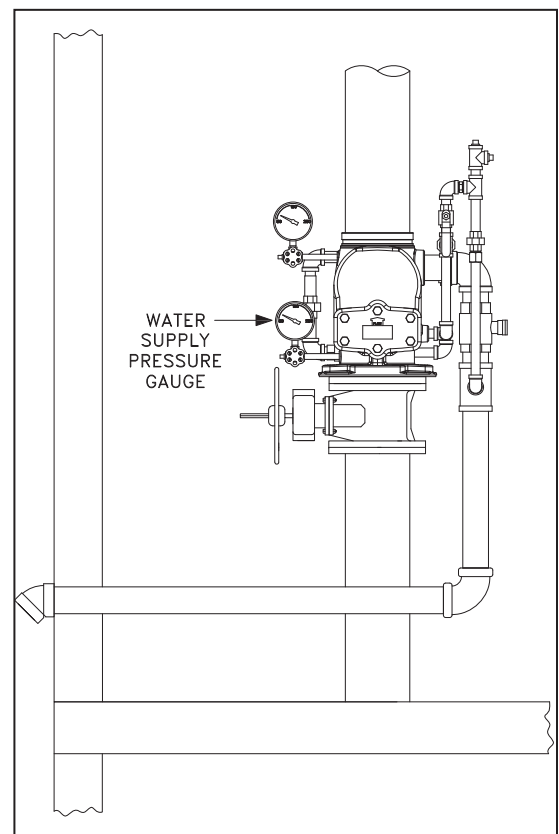

Figure 40



TECHNICAL DATA

WET PIPE SPRINKLER SYSTEM

The Viking Corporation, 210 N Industrial Park Drive, Hastings MI 49058

Telephone: 269-945-9501 Technical Services 877-384-5464 Fax: 269-818-1680 Email: techsvcs@vikingcorp.com

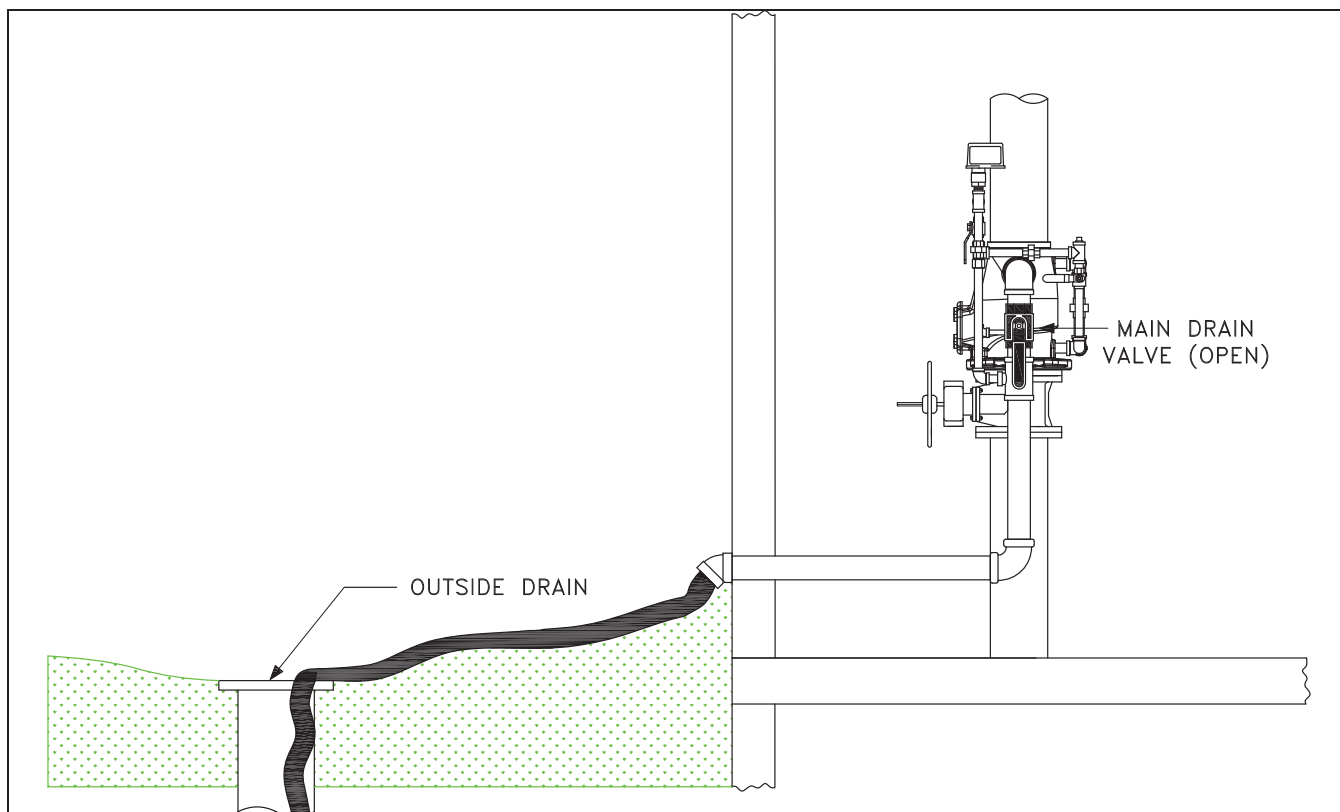

Figure 41

6. When a full flow is developed from the main drain, record the residual pressure from the water supply pressure gauge (Figure 42).
7. When the test is complete, SLOWLY CLOSE the main drain (Figure 43).
8. Compare test results with previous flow information. If there is a 10 percent reduction in full flow pressure when compared to the original acceptance test or previously performed tests, the cause of the reduction shall be identified and appropriate steps taken to restore adequate water supply. Check the main supply line for obstructions or closed valves.
9. Verify that normal water supply pressure has been restored, and that all alarm devices and valves are secured in normal operating position (Figure 44).
10. Notify the Authority Having Jurisdiction, remote station alarm monitors, and those in the area affected by the test that the test is complete. Record and/or provide notification of test results as required by the Authority Having Jurisdiction.

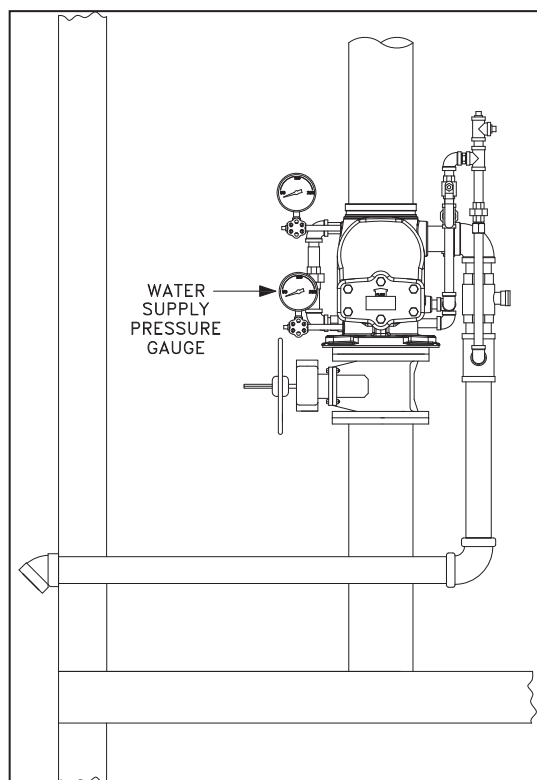

Figure 42

VIKING® **TECHNICAL DATA** **WET PIPE SPRINKLER SYSTEM**

The Viking Corporation, 210 N Industrial Park Drive, Hastings MI 49058
Telephone: 269-945-9501 Technical Services 877-384-5464 Fax: 269-818-1680 Email: techsvcs@vikingcorp.com

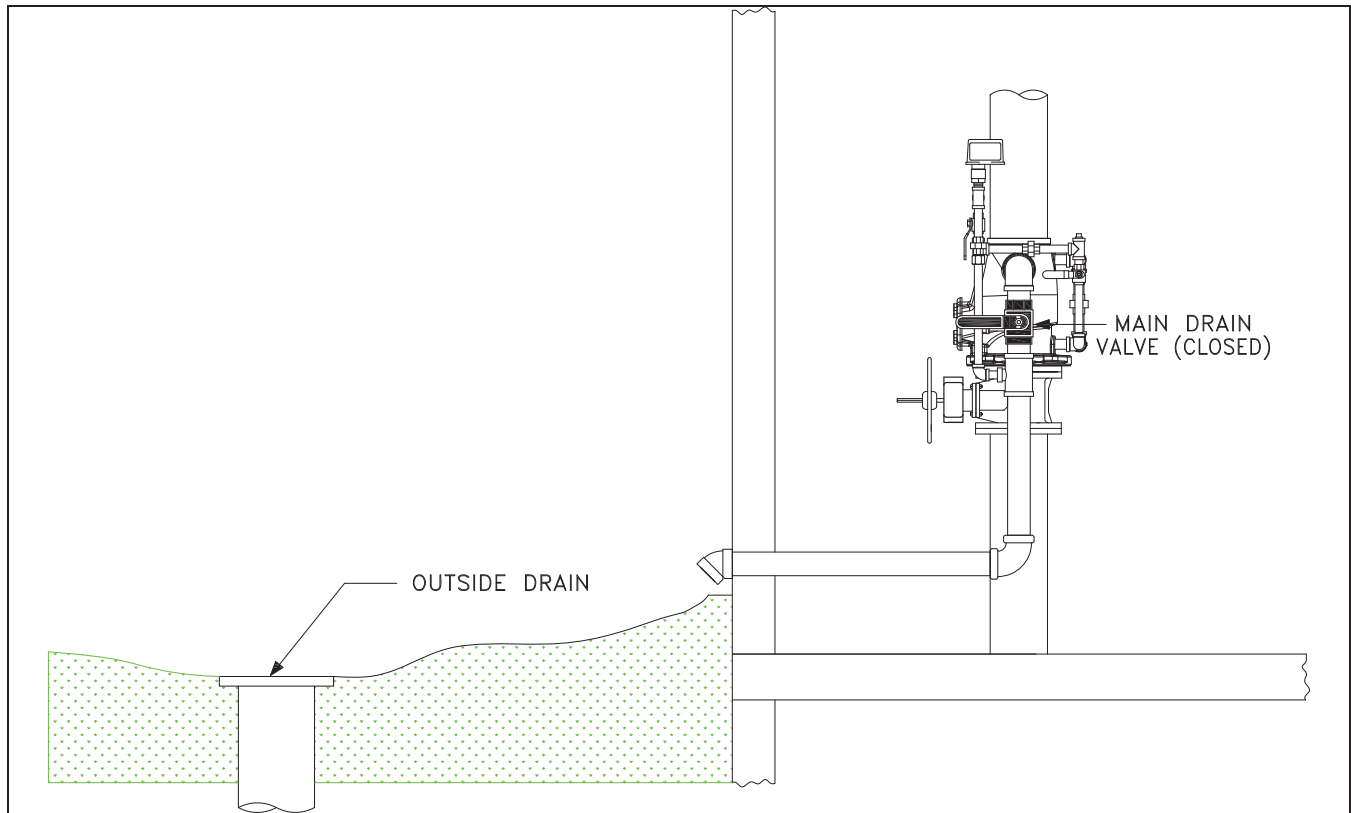

Figure 43

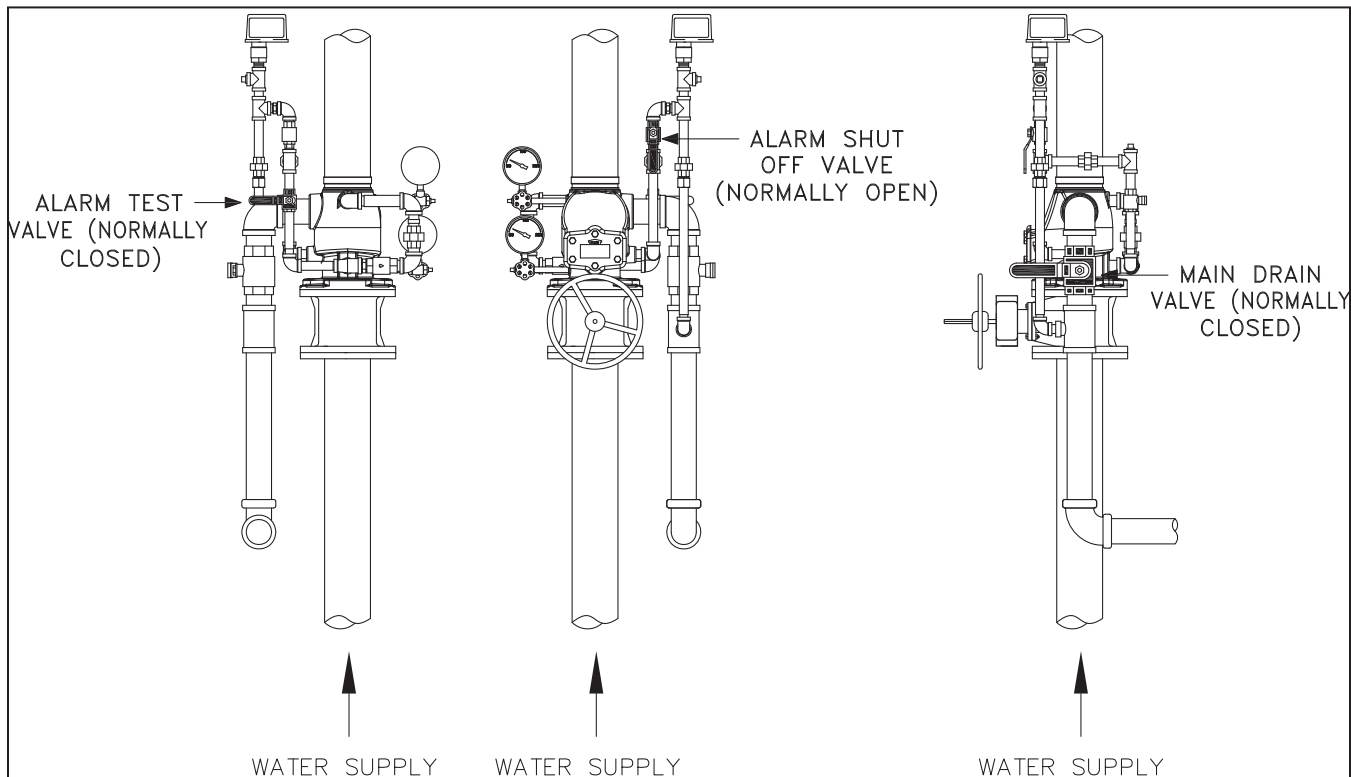

Figure 44



TECHNICAL DATA

WET PIPE SPRINKLER SYSTEM

The Viking Corporation, 210 N Industrial Park Drive, Hastings MI 49058

Telephone: 269-945-9501 Technical Services 877-384-5464 Fax: 269-818-1680 Email: techsvcs@vikingcorp.com

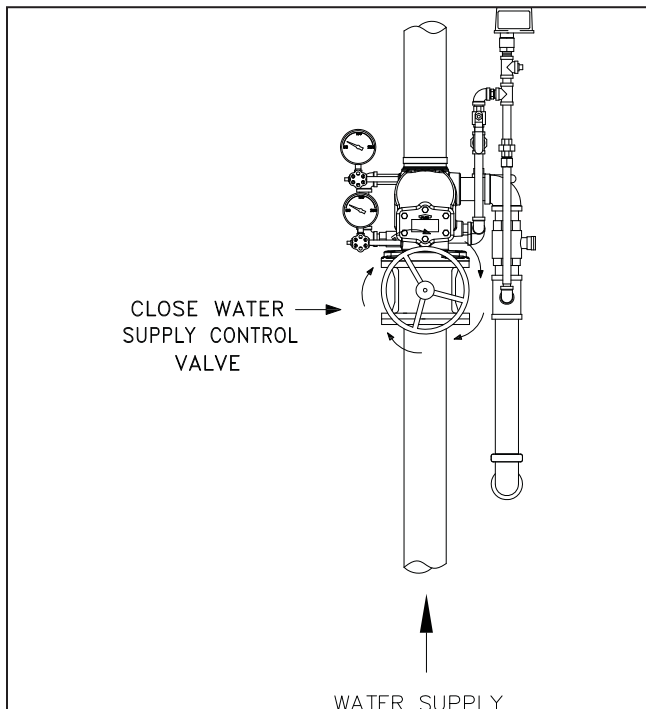

Figure 45

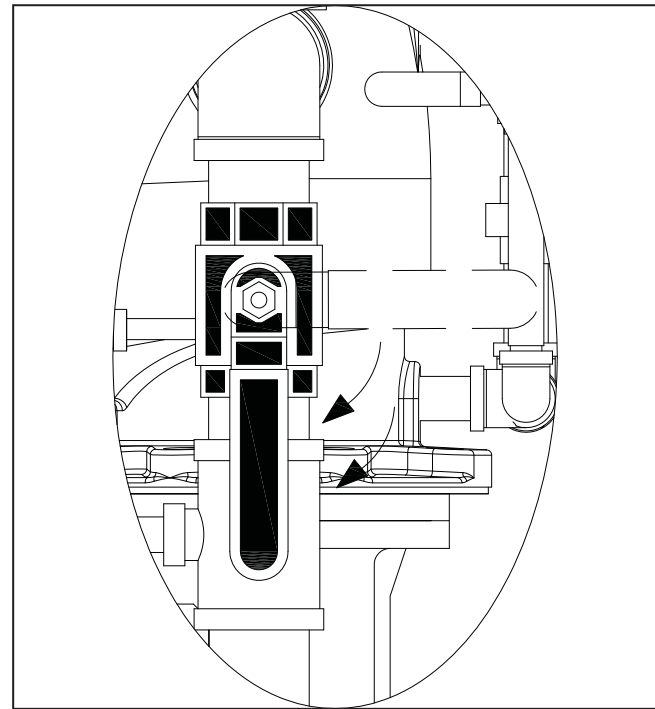
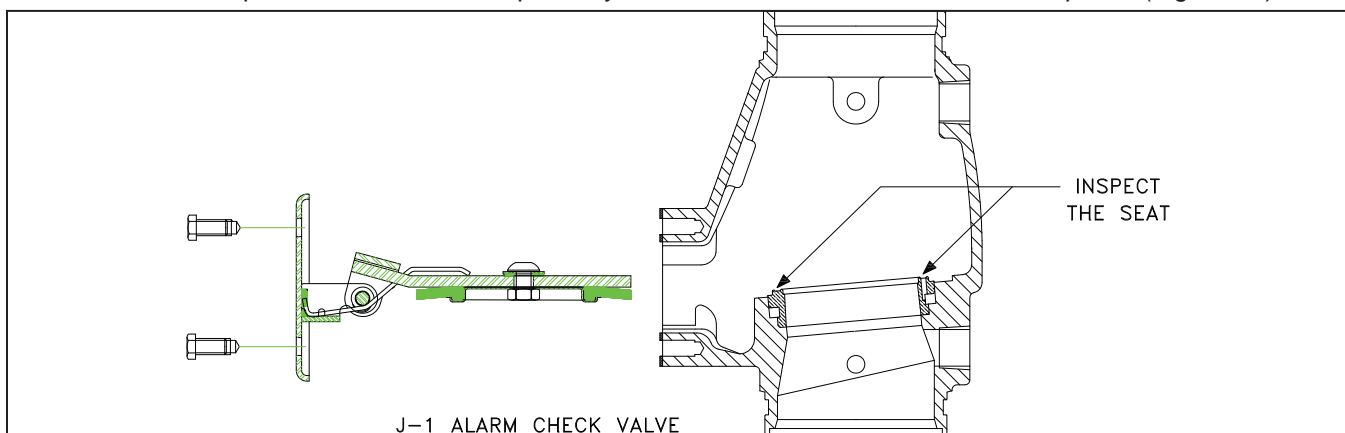

Figure 46

C. Five-Year Internal Inspection

Internal inspection of check valves is recommended every five years unless inspections and tests indicate more frequent internal inspections are required.

1. Notify the Authority Having Jurisdiction, remote station alarm monitors, and those in the area affected that the system will be taken out of service. Consideration should be given to employment of a fire patrol in the affected areas.
2. Close the water supply main control valve, placing the system out of service (Figure 45).
3. Open the main drain (Figure 46). If necessary, open the system test valve to vent and completely drain the system.
4. Use appropriate wrench to loosen and remove cover screws, and remove the cover/clapper assembly. (For the Model M-2 Check Valve, remove the valve from the system.)
5. Inspect the water seat. Wipe away all contaminants, dirt, and mineral deposits (Figure 47).



J-1 ALARM CHECK VALVE

Figure 47

	TECHNICAL DATA	WET PIPE SPRINKLER SYSTEM
---	-----------------------	----------------------------------

The Viking Corporation, 210 N Industrial Park Drive, Hastings MI 49058
 Telephone: 269-945-9501 Technical Services 877-384-5464 Fax: 269-818-1680 Email: techsvcs@vikingcorp.com

Clean any orifices in the seat that are restricted or plugged by mineral deposits. Do not use solvents or abrasives.

6. Inspect the cover/clapper assembly and cover gasket or rubber (Model M-2 Check Valve) (Figure 48). Test the hinged clapper for freedom of movement (if applicable) (Figure 49). For the Model J-1 Alarm Check Valve, test the spring for tension retention (Figure 50). Spring tension should engage when the top of hinged clapper is moved from perpendicular to the cover toward the open (flow) position. Renew or replace damaged or worn parts as required.

NOTE: The clapper assembly on the Model M-2 Check Valve is not replaceable. If it is determined that the clapper is damaged, the valve must be replaced.

CAUTION: NEVER APPLY ANY LUBRICANT TO SEATS, GASKETS, OR ANY INTERNAL OPERATING PARTS OF THE VALVE. PETROLEUM-BASED GREASE OR OIL WILL DAMAGE RUBBER COMPONENTS AND MAY PREVENT PROPER OPERATION.

7. When internal inspection of the check valve is complete, perform step 6 of the Maintenance paragraph to re-install cover/clapper assembly.
8. Place the wet system back in service. Refer to the Placing the System in Service.

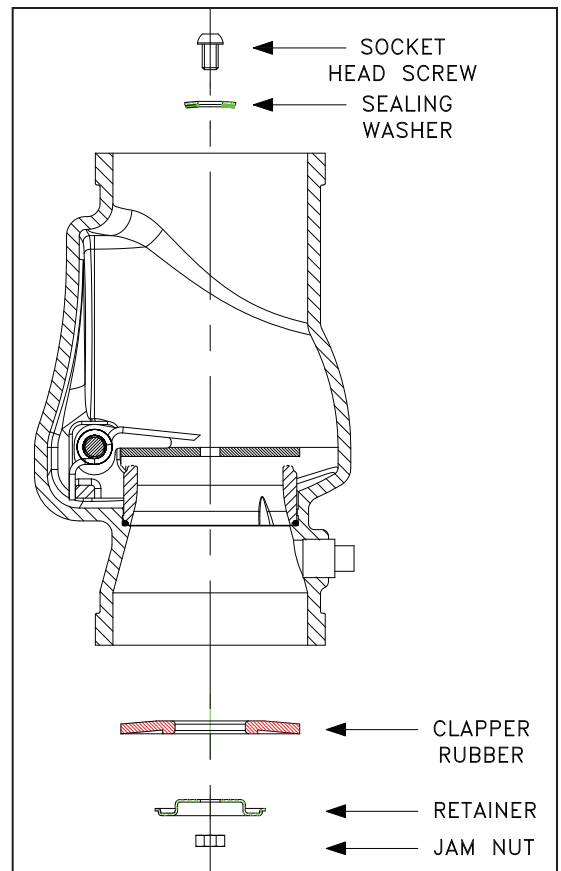

Figure 48

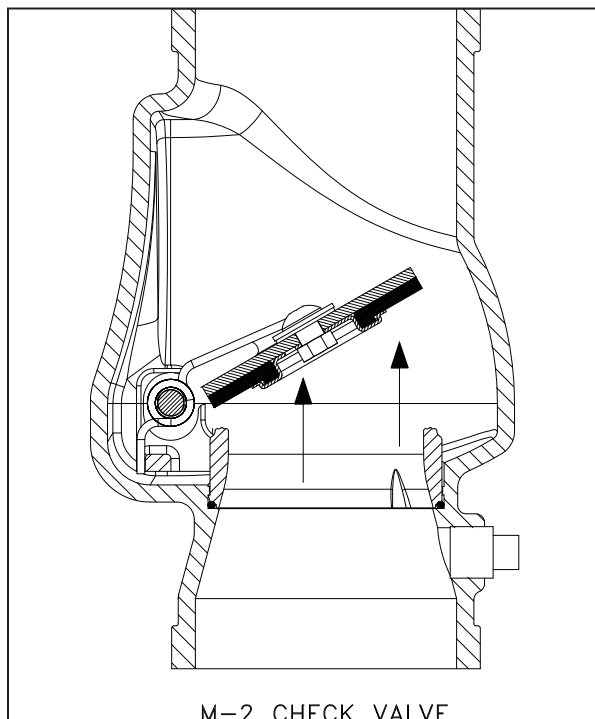

Figure 49

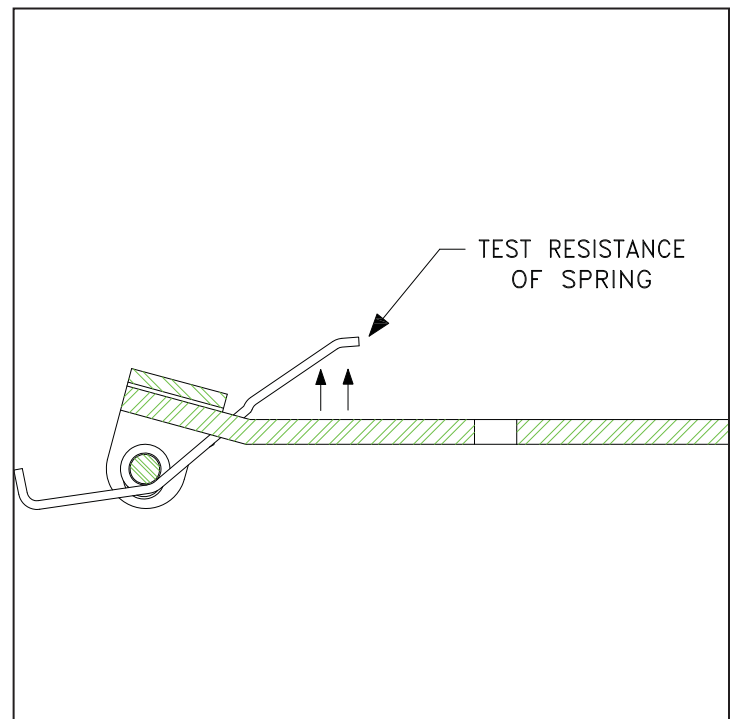

Figure 50



TECHNICAL DATA

WET PIPE SPRINKLER SYSTEM

The Viking Corporation, 210 N Industrial Park Drive, Hastings MI 49058

Telephone: 269-945-9501 Technical Services 877-384-5464 Fax: 269-818-1680 Email: techsvcs@vikingcorp.com

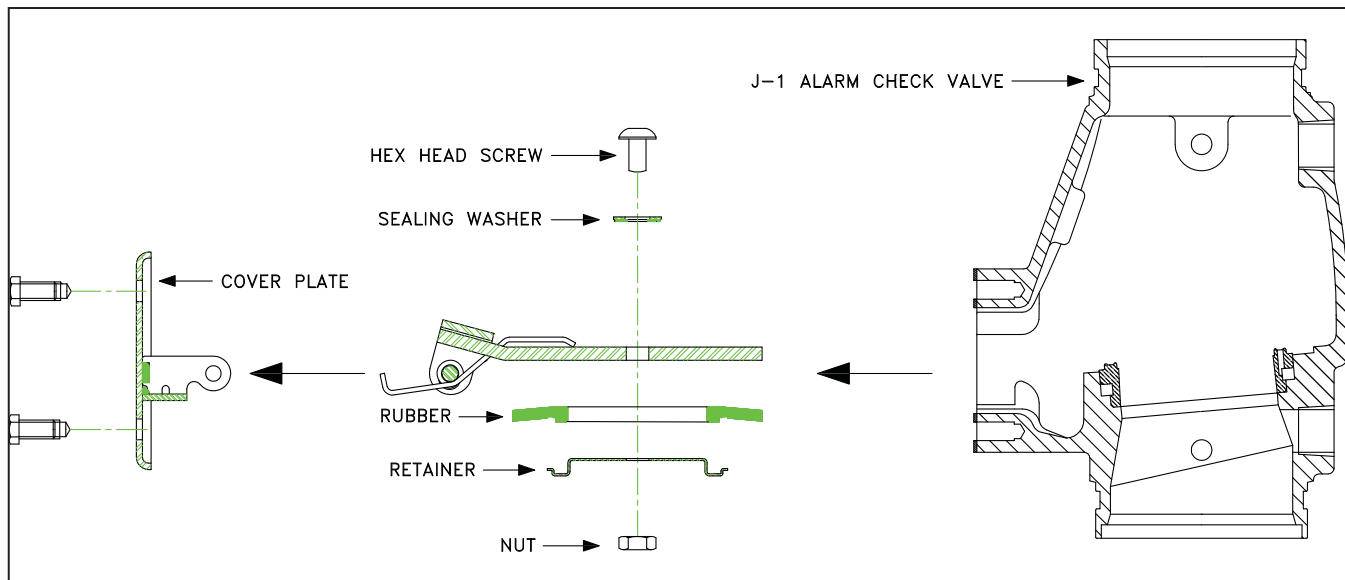

Figure 51

D. Maintenance

NOTE: For the Viking ESFR Cold Storage System, refer to data page 45a-j for maintenance instructions.

1. Perform steps 1 through 6 of the Five Year Internal Inspection section.
2. To remove the clapper rubber (Figure 51):
 - a. Use the appropriate wrench to loosen and remove the button-head socket screw, hex nut, sealing washer, and rubber retainer.
 - b. Remove the clapper rubber for inspection. If the clapper rubber shows signs of wear such as cracking, cuts, or excessively deep grooves where the rubber contacts the water seat, replace the rubber.
3. To re-install the clapper rubber:
 - a. Place the clapper rubber over the center hub of the rubber retainer.
 - b. Position the retainer (with rubber in place) against the clapper as shown in Figure 52.
 - c. Replace and tighten the button-head socket screw, sealing washer, and hex nut, as shown in Figure 52. The sealing washer and hex nut must be located on the top side of the clapper as shown. Do not over-tighten.
4. To remove the clapper, spring (Model J-1 Alarm Check Valve), and/or hinge pin (Figure 53):

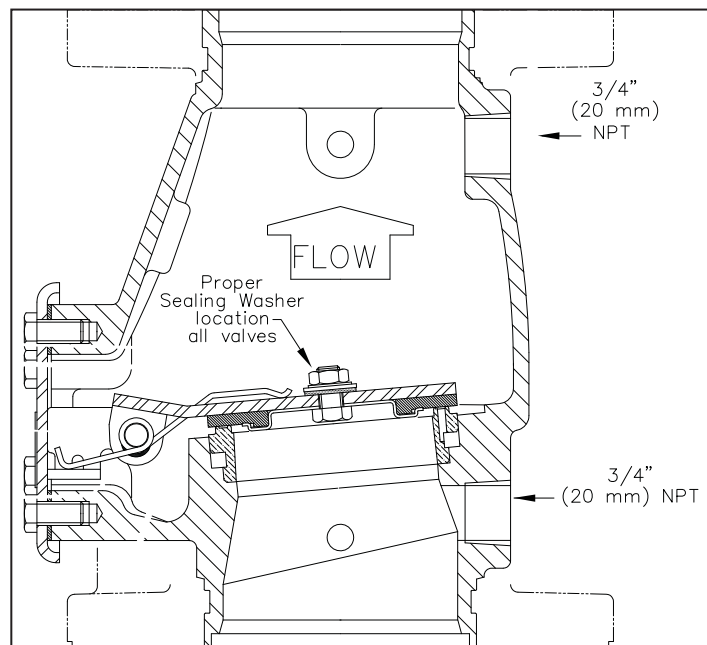

Figure 52



The Viking Corporation, 210 N Industrial Park Drive, Hastings MI 49058
 Telephone: 269-945-9501 Technical Services 877-384-5464 Fax: 269-818-1680 Email: techsvcs@vikingcorp.com

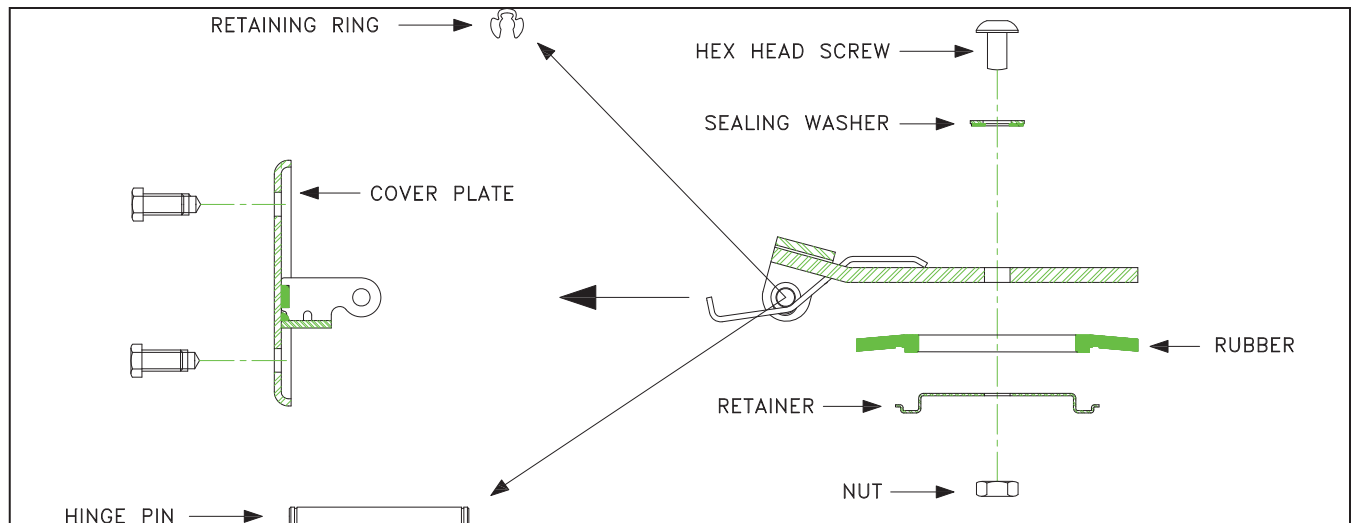

Figure 53

- a. Remove hinge pin retaining rings, to free the hinge pin for removal. After the hinge pin is removed, the clapper and spring (if applicable) can be removed.
5. To re-install clapper, spring (if applicable), and/or hinge pin:
 - a. Verify that the clapper rubber is in good condition and that it is properly installed.
 - b. Position the clapper with the elongated hinge holes aligned between the holes of the hinge bracket welded inside the cover. The system (top) side of the clapper must face the direction indicated by the flow arrow stamped inside the cover.
 - c. Insert the hinge pin through the holes at one end of the hinge assembly. Before continuing, re-install the spring (if applicable), using care to orient the spring as shown in Figure 52. Continue to push the hinge pin through the holes at the remaining end of the hinge assembly.
 - d. Re-install the hinge pin retaining rings.
6. To re-install the cover/clapper assembly:
 - a. Verify that the cover gasket is in position and that it is in good condition.
 - b. Slide the cover/clapper assembly into the check valve so that the clapper rubber contacts the grooved water seat.
 - c. Replace the cover screws. Use the appropriate wrench to evenly cross-tighten all screws to the torque values listed for the valve used. **DO NOT** over-tighten.
7. To place the wet system back in service, refer to the Placing the System in Service.

X. REMOVING THE SYSTEM FROM SERVICE

WARNING: The system should be placed out of service only for repairs. The work must be completed in a manner to minimize the time that the system must be out of service. All hazardous activities in the affected area shall be terminated until the system is placed back in service. Any system impairment shall be coordinated with the owner, local authority having jurisdiction, and other related parties. Place a roving fire patrol in the area covered by the system until the system is back in service.

Prior to turning off any valves or activating any alarms, notify local security guards and/or central alarm station (if used) so that a false alarm will not be signalled and result in a local fire department response.

1. Close the water supply control valve.
2. Open the main drain valve.



TECHNICAL DATA

WET PIPE SPRINKLER SYSTEM

The Viking Corporation, 210 N Industrial Park Drive, Hastings MI 49058

Telephone: 269-945-9501 Technical Services 877-384-5464 Fax: 269-818-1680 Email: techsvcs@vikingcorp.com

3. Open all auxiliary drain valves and inspectors test valve.
4. System and supply pressure gauges should now read zero.
5. If system will be subject to freezing, drain any trapped water in the system, devices, valve, and trim.
6. Place a system-out-of-service sign in a visible location.

XI. USE OF DRY SPRINKLERS IN WET SYSTEMS

Note About Using Dry Sprinklers: Dry sprinklers can be used on wet pipe systems where individual sprinklers are extended into spaces that are subject to freezing. One example of this application is extending dry sprinklers into a freezer unit. A minimum length for the dry sprinkler's exposed portion outside the freezer is specified to avoid freezing water at the connection point to the branch line (refer to Figure 54 below). Dry sprinklers have a maximum length of up to 4 ft (1.2 m). Dry sprinklers connected to wet systems protecting insulated freezer structures must have the clearance space sealed around the sprinkler barrel.

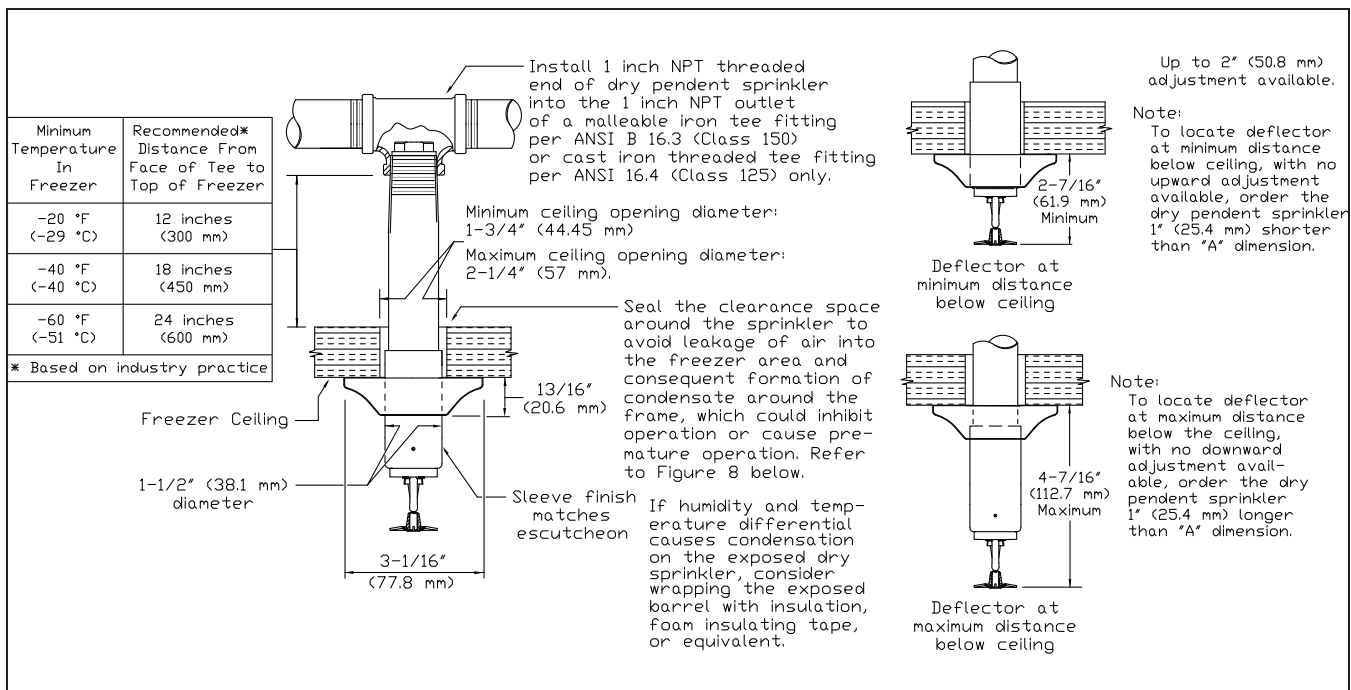

Figure 54

XII. TROUBLESHOOTING VIKING WET SYSTEMS

A. Alarm Fails to Sound on Test

- For systems with mechanical alarms, clean water motor and strainers in the alarm line.
- For systems with an alarm pressure switch, check the power source and wiring.
- Check bell for obstructions. If the alarm still fails, call your Viking representative.

B. Water Supply Pressure Gauge Drops on the Flow Test

- Immediately check Driveway valve and post indicator or control valve. If both are open, immediately call your Viking representative, as a line obstruction is indicated.



The Viking Corporation, 210 N Industrial Park Drive, Hastings MI 49058
 Telephone: 269-945-9501 Technical Services 877-384-5464 Fax: 269-818-1680 Email: techsvcs@vikingcorp.com

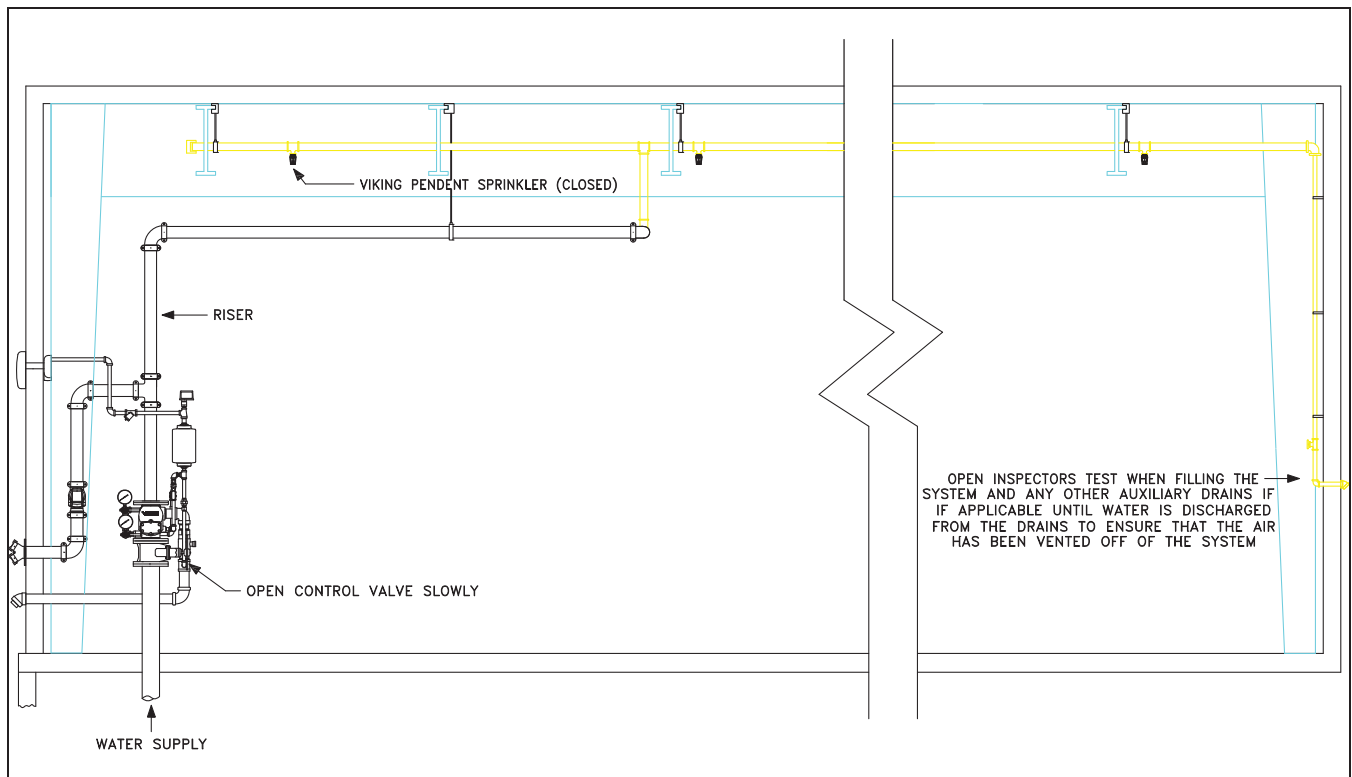

Figure 55

C. Alarm Sounds Immediately on Alarm Test

- For systems using the Model J-1 Alarm Check Valve, clean orifice tee or retarding chamber drain restriction, or
- For systems using the Model E-1 Easy Riser® Swing Check Valve (with a waterflow indicator): during surges, the paddle will move. The switch mechanism is provided with a pneumatic time delay to prevent closing of the alarm line circuit. The time delay can be adjusted from 0 to 90 seconds (see the section on the waterflow indicator device).

D. Intermittent Alarms

Intermittent alarms are usually caused by air being trapped in the system. If the system is a new installation or has recently been added on to or revised, then it is very likely that air is trapped in the system, and it causes the clapper on the Model J-1 Alarm Check Valve or Easy Riser® to open and close (cycle), thereby causing intermittent alarming. The contractor will have to go back, drain down the system, open all auxiliary drains, then re-fill it, shutting off each low point drain when a steady stream of water flows from it. Refer to Figure 55.

- Bleed air from the high points of the system. If system pressure is seldom, if ever, greater than supply pressure, drain the system and:
- Check the alarm valve rubber and by-pass check valve rubber for cold flow and sealing efficiency (if the Model J-1 Alarm Check Valve is used), or
- Check the check valve rubber for cold flow and sealing efficiency (if the Model E-1 Easy Riser® Swing Check Valve is used)
- Clean valve seats and replace rubbers as necessary.



TECHNICAL DATA

WET PIPE SPRINKLER SYSTEM

The Viking Corporation, 210 N Industrial Park Drive, Hastings MI 49058

Telephone: 269-945-9501 Technical Services 877-384-5464 Fax: 269-818-1680 Email: techsvcs@vikingcorp.com

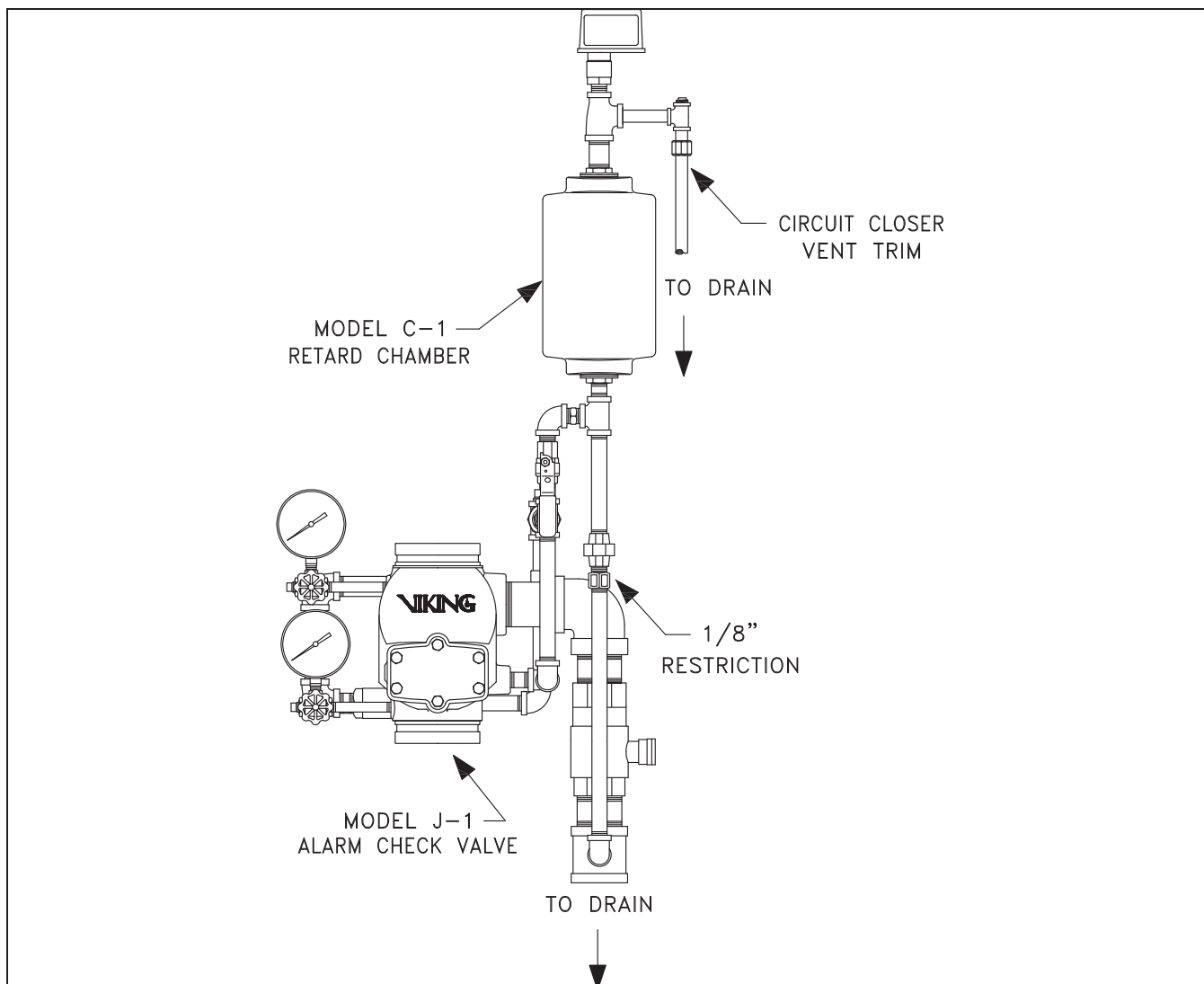

Figure 56

Ask: When does the cycling occur?

There may be a fire pump test going on at the time of the cycling, and the pump could be causing surges in the water pressure. There also may not be circuit closer vent trim on the retard chamber (Figure 56), if there is no water motor alarm gong. Therefore, circuit closer vent trim would break the vacuum in the retard chamber, relieving the trapped pressure on the pressure switch.

Ask: Is there an intermittent alarm when the inspector's test valve is opened?

There may be some air trapped in the system, causing air compression in the piping, and the clapper of the alarm valve will cycle open and closed when there is a flow equivalent to only one sprinkler.

One way to try and alleviate this problem is to suggest that the contractor install a ball valve in the inspector's test line, rather than a globe valve, as the ball valve does not restrict the water flow like a globe valve would.



TECHNICAL DATA

WET PIPE SPRINKLER SYSTEM

The Viking Corporation, 210 N Industrial Park Drive, Hastings MI 49058

Telephone: 269-945-9501 Technical Services 877-384-5464 Fax: 269-818-1680 Email: techsvcs@vikingcorp.com

Make the piping 1" all the way out to the sprinkler test orifice can also help the situation, as NFPA does not allow for piping smaller than 1" on sprinkler systems other than for residential. Note that NFPA 13 does allow for an intermittent alarm (section 6.9.1) and does not state that a constant alarm is required. It simply states that it must result in an audible alarm within 5 minutes after the flow begins, and until such flow stops.

E. False Alarms

For proper operation and maintenance of a wet pipe system using the Viking Model J-1 Alarm Check Valve, there are many things that need to be monitored on a regular basis. And if that system has been experiencing false alarms, there are some key things to look for, questions to ask.

If water pressure surges produce false alarms, check the following:

- For systems using the Model J-1 Alarm Check Valve, make sure the valve has been trimmed exactly as shown on Viking trim sheets with no deviations. The trim size and fitting arrangement is required for proper operation.
- Ensure that the alarm test valve is turned off. If vandalism is suspected, it is important that the alarm test valve inspector's test valve and all other drain valves be secured in the closed position.
- Air trapped in the sprinkler piping can cause false alarms, the alarms to cycle on and off during testing, and other nuisance problems. To correct, bleed as much air as possible from the trapped high points of system piping. This condition can be minimized by opening the remote inspector's test valve and slowly filling the system with water when placing the system in service. Some piping configurations will require additional air venting. Trapped air, besides causing false alarm problems, can also cause the water flow alarm to cycle on and off whenever an inspector's test valve is used.
- Check for leaks in the system. A faulty main drain valve or inspector's test valve can cause false alarms. Both should be checked and maintained.
- For systems using the Model J-1 Alarm Check Valve:
 1. Clean drain restriction on retard chamber trim. When servicing a retard chamber, it's important to verify if it is properly installed and that the restrictions are clear and clean. If the vent restriction is going to work properly, a minimum 1/4" drain pipe must be used. Even minor corrosion or obstructions in the pipe will keep the vent from working. A larger 1/2" pipe is preferred.
 2. Clean or replace check valve on external by-pass trim (Figure 57). If both the supply gauge and system gauge are fluctuating up and down at the same time, it is likely that the bypass check valve is leaking. (Refer to Figures 58-59.) If there are unusual fluctuations on both the supply side and system gauges, be sure to check the bypass check valve.

First, close the system supply valve. Then, break the union in the alarm test line and open the normally closed alarm test valve to see if water flows back to the system through the check valve.

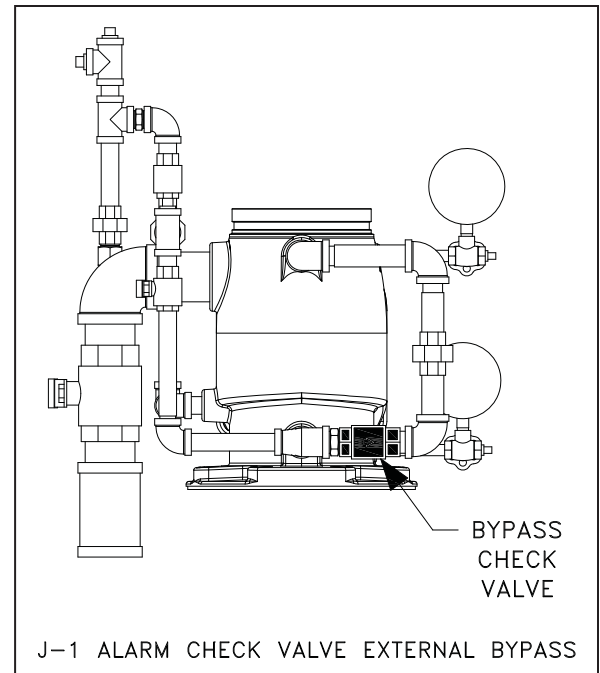

Figure 57



TECHNICAL DATA

WET PIPE SPRINKLER SYSTEM

The Viking Corporation, 210 N Industrial Park Drive, Hastings MI 49058
Telephone: 269-945-9501 Technical Services 877-384-5464 Fax: 269-818-1680 Email: techsvcs@vikingcorp.com

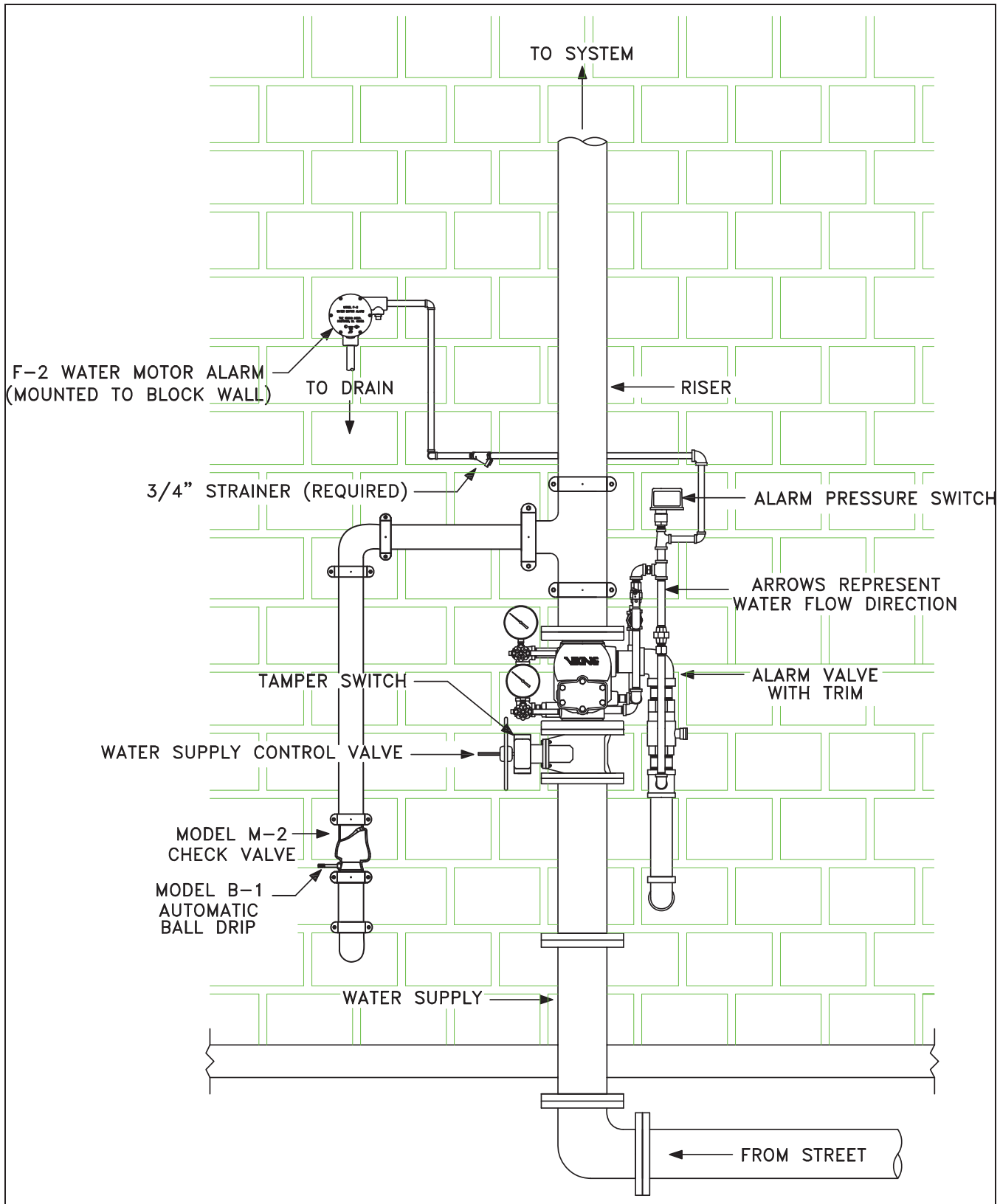

Figure 58

VIKING® **TECHNICAL DATA** **WET PIPE SPRINKLER SYSTEM**

The Viking Corporation, 210 N Industrial Park Drive, Hastings MI 49058
Telephone: 269-945-9501 Technical Services 877-384-5464 Fax: 269-818-1680 Email: techsvcs@vikingcorp.com

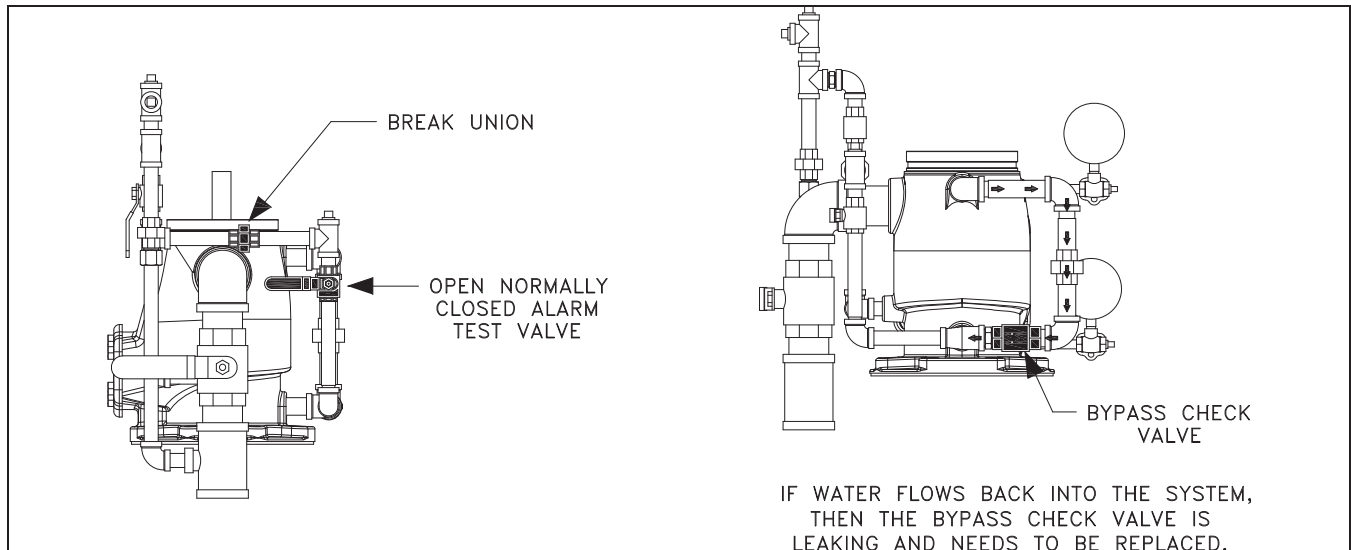

Figure 59

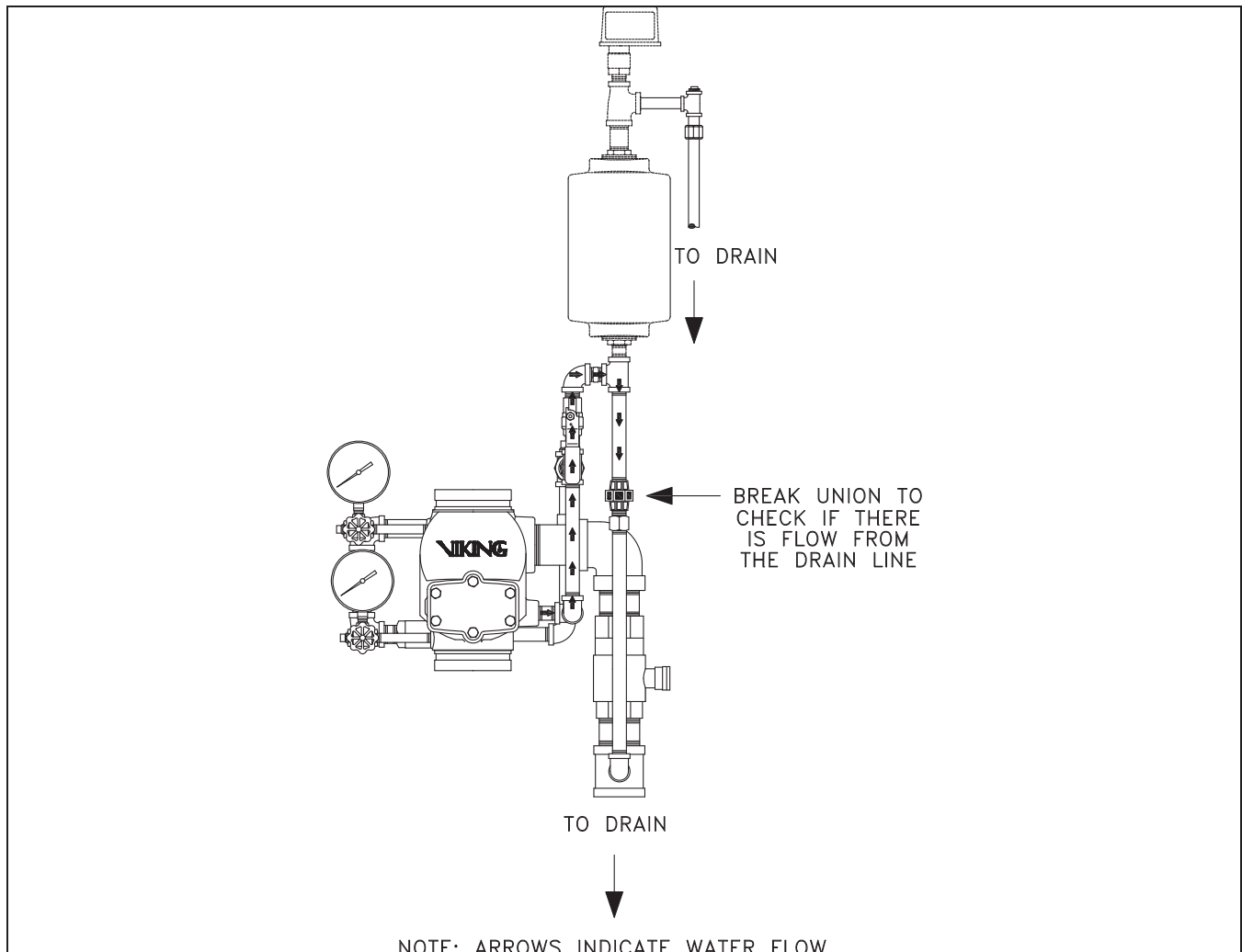

Figure 60



TECHNICAL DATA

WET PIPE SPRINKLER SYSTEM

The Viking Corporation, 210 N Industrial Park Drive, Hastings MI 49058

Telephone: 269-945-9501 Technical Services 877-384-5464 Fax: 269-818-1680 Email: techsvcs@vikingcorp.com

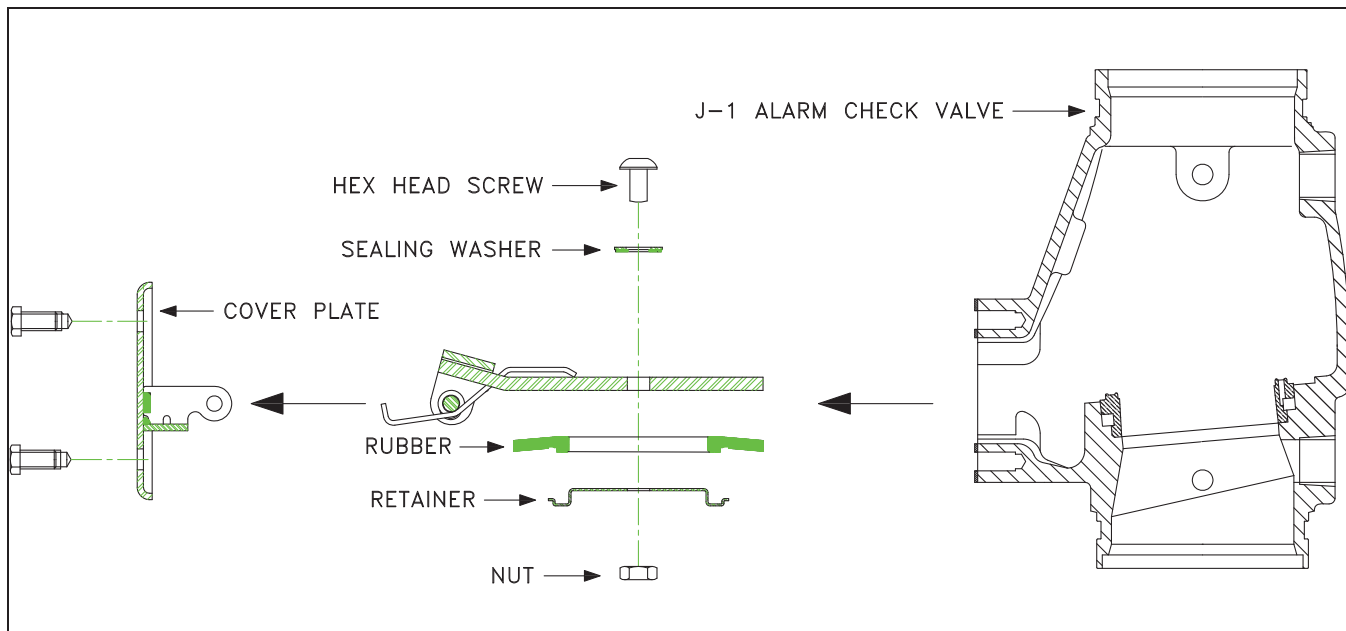

Figure 61

3. If the bypass check valve is not leaking, the second thing to do is clean or replace alarm valve clapper rubber. (Refer to Figure 60.) Begin by breaking the union in the retard chamber drain line to check the flow from the drain line.
 If there is flow, drain the system and remove the face plate where the clapper assembly is connected. To replace the rubber, remove the hex head screw, the rubber retainer, and the clapper rubber. (Refer to Figure 61.) Re-assemble by reversing the procedure. After re-installing the clapper and face plate, returning the system to service, perform alarm tests and riser flow test procedure specified in Viking's technical literature.
4. Add retard chamber and drain restriction if not provided. Stacking another Model C-1 Retard Chamber on top of the original one may also help to absorb the cycling alarm water, allowing it to run to drain before it can ring the alarm.